

**PNS SCHOOL OF ENGINEERING AND TECHNOLOGY
NISHAMANI VIHAR, MARSHAGHAI, KENDRAPARA**

**DEPARTMENT OF ELECTRONICS AND TELECOMMUNICATION
ENGINEERING**



LECTURER'S NOTES

Semester: 5th Semester

Subject: Wave propagation & Broadband communication Engineering

Prepared By:

Er. AMARENDRA SAHOO

HOD DEPT. OF ETC

Detailed Contents:

Unit-1: WAVE PROPAGATION & ANTENNA

- 1.1 Effects of environments such as reflection, refraction, interference, diffraction, absorption and attenuation (Definition only)
- 1.2 Classification based on Modes of Propagation-Ground wave, Ionosphere, Sky wave propagation, Space wave propagation
- 1.3 Definition – critical frequency, max. useable frequency, skip distance, fading, Duct propagation & Troposphere scatter propagation actual height and virtual height
- 1.4 Radiation mechanism of an antenna-Maxwell equation.
- 1.5 Definition - Antenna gains, Directive gain, Directivity, effective aperture, polarization, input impedance, efficiency, Radiator resistance, Bandwidth, Beam width, Radiation pattern
- 1.6 Antenna -types of antenna: Mono pole and dipole antenna and omni directional antenna
- 1.7 Operation of following antenna with advantage & applications.
 - a) Directional high frequency antenna : , Yagi & Rohmbus only
 - b) UHF & Microwave antenna.: Dish antenna (with parabolic reflector) & Horn antenna
- 1.8 Basic Concepts of Smart Antennas- Concept and benefits of smart antennas

Unit-2: TRANSMISSION LINES.

- 2.1 Fundamentals of transmission line.
- 2.2 Equivalent circuit of transmission line & RF equivalent circuit
- 2.3 Characteristics impedance, methods of calculations & simple numerical.
- 2.4 Losses in transmission line.
- 2.5 Standing wave – SWR, VSWR, Reflection coefficient, simple numerical.
- 2.6 Quarter wave & half wavelength line
- 2.7 Impedance matching & Stubs – single & double
- 2.8 Primary & secondary constant of X-mission line.

Unit-3: TELEVISION ENGINEERING.

- 3.1 Define-Aspect ratio, Rectangular Switching. Flicker, Horizontal Resolution, Video bandwidth, Interlaced scanning, Composite video signal, Synchronization pulses
- 3.2 TV Transmitter – Block diagram & function of each block.
- 3.3 Monochrome TV Receiver -Block diagram & function of each block.
- 3.4 Colour TV signals (Luminance Signal & Chrominance Signal, (I & Q, U & V Signals).
- 3.5 Types of Televisions by Technology- cathode-ray tube TVs, Plasma Display Panels, Digital Light Processing (DLP), Liquid Crystal Display (LCD), Organic Light-Emitting Diode (OLED) Display, Quantum Light-Emitting Diode (QLED)
– **only Comparison based on application**
- 3.6 Discuss the principle of operation - LCD display, Large Screen Display.
- 3.7 CATV systems & Types & networks
- 3.8 Digital TV Technology-Digital TV Signals, Transmission of digital TV signals & Digital TV receiver Video programmeprocessor unit.

Unit-4: MICROWAVE ENGINEERING.

- 4.1 Define Microwave Wave Guides.
- 4.2 Operation of rectangular wave guides and its advantage.
- 4.3 Propagation of EM wave through wave guide with TE & TM modes.
- 4.4 Circular wave guide.
- 4.5 Operational Cavity resonator.
- 4.6 Working of Directional coupler, Isolators & Circulator.
- 4.7 Microwave tubes-Principle of operational of two Cavity Klystron.
- 4.8 Principle of Operations of Travelling Wave Tubes
- 4.9 Principle of Operations of Cyclotron
- 4.10 Principle of Operations of Tunnel Diode & Gunn diode

Unit-5: Broadband communication

5.1 Broadband communication system-Fundamental of Components and Network architecture

5.2 Cable broadband data network- architecture, importance & future of broadband telecommunication internet based network.

5.3 SONET(Synchronous Optical Network)-Signal frame components topologies advantages applications, and disadvantages

5.4 ISDN - ISDN Devices interfaces, services, Architecture, applications,

5.5 BISDN -interfaces & Terminals, protocol architecture applications

Books Recommended:

1. Electronics Communication by G. Kennedy- MGH

2. Broadband Communication by Balaji Kumar (Reference)

COURSE OUTCOME:

After the completion of the course the students will be able to-

C01-Analyze various methods of radio wave propagation and explain different propagation terms such as critical frequency, maximum usable frequency virtual height, skip distance, fading & ducting.

C02-Analyze different parameters of antenna for real time applications.

C03- Characterize transmission line parameters using distributed model and solve simple SWR, reflection coefficient, impedance matching using analytical method.

C04-Recognize the limitation of existing vacuum tubes at microwave frequency and explain working of microwave components such as isolator, circulator, directional coupler, klystron, TWT & wave guide.

C05-Sketch the block diagram of monochrome & color TV transmitter and receiver also identify the components of a monochrome & color TV and explain i

Wave Propagation

Spectrum & Transmission

In the Earth's atmosphere, the propagation of wave depends not only on the properties of the wave, but also on environment effects and the layers of earth's atmosphere. All of these have to be studied in order to form an idea of how a wave propagates in the environment.

Let us look at the **frequency spectrum** over which the signal transmission or reception takes place. Different types of antennas are manufactured depending upon the frequency range in which they are operated.

Electromagnetic Spectrum

Wireless communication is based on the principle of broadcast and reception of electromagnetic waves. These waves can be characterized by their frequency (f) and their wavelength (λ) lambda.

A pictorial representation of the electromagnetic spectrum is given in the following figure.

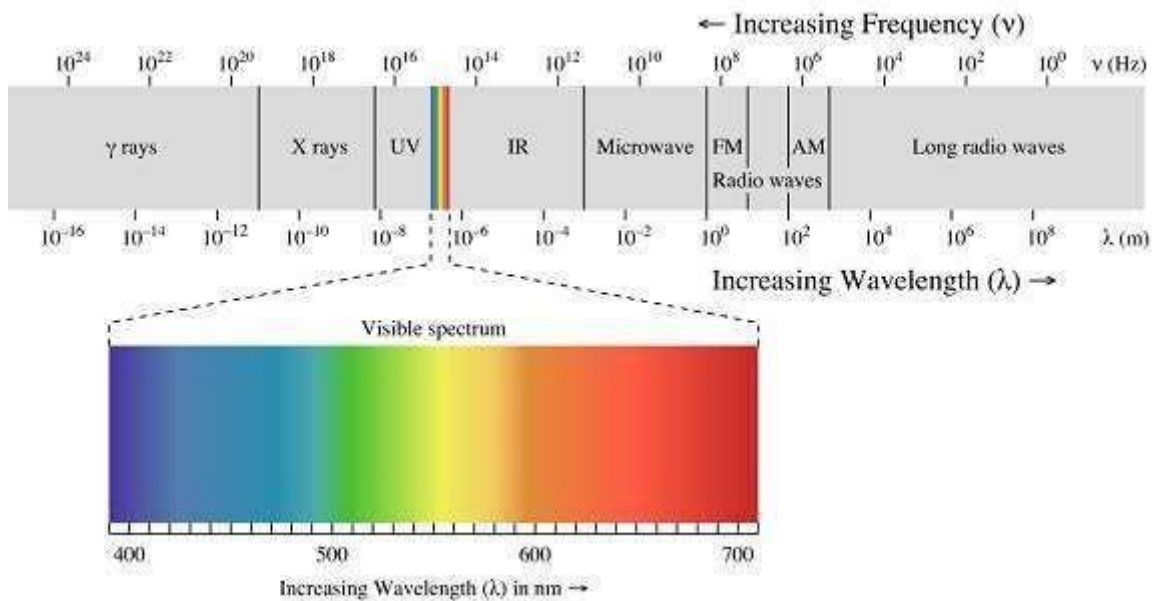

Low Frequency bands

Low Frequency bands comprise of the radio, microwave, infrared and visible portions of the spectrum. They can be used for information transmission by modulating the amplitude, frequency or phase of the waves.

High Frequency bands

High Frequency bands comprise of X-rays and Gamma rays. Theoretically, these waves are better for information propagation. However, these waves are not used practically because of difficulty in modulation and the waves are harmful to living beings. In addition, high frequency waves do not propagate well through buildings.

Frequency Bands and their Uses

The following table depicts the frequency bands and its uses-

Band Name	Frequency	Wavelength	Applications
Extremely Low Frequency (ELF)	30 Hz to 300 Hz	10,000 to 1,000 KM	Power line frequencies
Voice Frequency (VF)	300 Hz to 3 KHz	1,000 to 100 KM	Telephone Communications
Very Low Frequency (VLF)	3 KHz to 30 KHz	100 to 10 KM	Marine Communications
Low Frequency (LF)	30 KHz to 300 KHz	10 to 1 KM	Marine Communications
Medium Frequency (MF)	300 KHz to 3 MHz	1000 to 100 m	AM Broadcasting
High Frequency (HF)	3 MHz to 30 MHz	100 to 10 m	Long distance aircraft/ship Communications
Very High Frequency (VHF)	30 MHz to 300 MHz	10 to 1 m	FM Broadcasting
Ultra High Frequency (UHF)	300 MHz to 3 GHz	100 to 10 cm	Cellular Telephone
Super High Frequency (SHF)	3 GHz to 30 GHz	10 to 1 cm	Satellite Communications, Microwave links
Extremely High Frequency (EHF)	30 GHz to 300 GHz	10 to 1 mm	Wireless local loop
Infrared	300 GHz to 400 THz	1 mm to 770 nm	Consumer Electronics
Visible Light	400 THz to 900 THz	770 nm to 330 nm	Optical Communications

Spectrum Allocation

Since the electromagnetic spectrum is a common resource, which is open for access by anyone, several national and international agreements have been drawn regarding the usage of the different frequency bands within the spectrum. The individual national governments allocate spectrum for applications such as AM/FM radio broadcasting, television broadcasting, mobile telephony, military communication, and government usage.

Worldwide, an agency of the International Telecommunications Union Radio Communication (**ITU-R**) Bureau called World Administrative Radio Conference (**WARC**) tries to coordinate the spectrum allocation by the various national governments, so that communication devices that can work in multiple countries can be manufactured.

Transmission Limitations

Four types of limitations that affect electromagnetic wave transmissions are-

Attenuation

According to the standard definition, "The decrease in the quality and the strength of the signal is known as **attenuation**."

The strength of a signal falls with distance over transmission medium. The extent of attenuation is a function of distance, transmission medium, as well as the frequency of the underlying transmission. Even in free space, with no other impairment, the transmitted signal attenuates over distance, simply because the signal is being spread over a larger and larger area.

Distortion

According to the standard definition, "Any change that alters the basic relation between the frequency components of a signal or the amplitude levels of a signal is known as **distortion**."

Distortion of a signal is the process, which causes disturbance to the properties of signal, adding some unwanted components, which affects the quality of the signal. This is usually observed in FM receiver, where the received signal, sometimes gets completely disturbed giving a buzzing sound as the output.

Dispersion

According to the standard definition, "**Dispersion** is the phenomenon, in which the velocity of propagation of an Electromagnetic wave is wavelength dependent."

Dispersion is the phenomenon of spreading of a burst of electromagnetic energy during propagation. It is especially prevalent in wireline transmissions such as an optical fiber. Bursts of data sent in rapid succession tend to merge due to dispersion. The longer the length of the wire, the more severe is the effect of dispersion. The effect of dispersion is to limit the product of R and L. Where '**R**' is the **data rate** and '**L**' is **distance**.

Noise

According to the standard definition, "Any unwanted form of energy tending to interfere with the proper and easy reception and reproduction of wanted signals is known as Noise."

The most pervasive form of noise is **thermal noise**. It is often modeled using an additive Gaussian model. Thermal noise is due to the thermal agitation of electrons and is uniformly distributed across the frequency spectrum.

Other forms of noise include-

- **Inter modulation noise:** Caused by signals produced at frequencies that are sums or differences of carrier frequencies.
- **Crosstalk:** Interference between two signals.
- **Impulse noise:** Irregular pulses of high energy caused by external electromagnetic disturbances. An impulse noise may not have a significant impact on analog data. However, it has a noticeable effect on digital data, causing burst errors.

Types of Propagation

In this chapter, let us go through different interesting topics such as the properties of radio waves, the propagation of radio waves and their types.

RadioWaves

Radio waves are easy to generate and are widely used for both indoor and outdoor communications because of their ability to pass through buildings and travel long distances.

The key features are-

- Since radio transmission is **Omni directional** in nature, the need to physically align the transmitter and receiver does not arise.
- The frequency of the radio wave determines many of the characteristics of the transmission.
- At low frequencies, the waves can pass through obstacles easily. However, their power falls with an inverse-squared relation with respect to the distance.
- The higher frequency waves are more prone to absorption by rain drops and they get reflected by obstacles.
- Due to the long transmission range of the radio waves, interference between transmissions is a problem that needs to be addressed.

In the VLF, LF and MF bands the propagation of waves, also called as **ground waves** follow the curvature of the earth. The maximum transmission ranges of these waves are of the order of a few hundred kilometers. They are used for low bandwidth transmissions such as Amplitude Modulation (AM) radio broadcasting.

The HF and VHF band transmissions are absorbed by the atmosphere, near the Earth's surface. However, a portion of the radiation, called the **sky wave**, is radiated outward and upward to the ionosphere in the upper atmosphere. The ionosphere contains ionized particles formed due to the Sun's radiation. These ionized particles reflect the sky waves back to the Earth. A powerful sky wave may be reflected several times between the Earth and the ionosphere. Sky waves are used by amateur ham radio operators and for military communication.

RadioWavePropagation

In **Radio communication systems**, we use wireless electromagnetic waves as the channel. The antennas of different specifications can be used for these purposes. The sizes of these antennas depend upon the bandwidth and frequency of the signal to be transmitted.

The mode of propagation of electromagnetic waves in the atmosphere and in free space may be divided into the following three categories-

- Line of sight (LOS) propagation
- Ground wave propagation
- Sky wave propagation

In ELF (Extremely low frequency) and VLF (Very low frequency) frequency bands, the Earth, and the ionosphere act as a wave guide for electromagnetic wave propagation.

In these frequency ranges, communication signals practically propagate around the world. The channel bandwidths are small. Therefore, the information is transmitted through these channels has slow speed and confined to digital transmission.

Line of Sight (LOS) Propagation

Among the modes of propagation, this line-of-sight propagation is the one, which we commonly notice. In the **line-of-sight communication**, as the name implies, the wave travels a minimum distance of sight. Which means it travels to the distance up to which a naked eye can see. Now what happens after that? We need to employ an amplifier cum transmitter here to amplify the signal and transmit again.

This is better understood with the help of the following diagram.

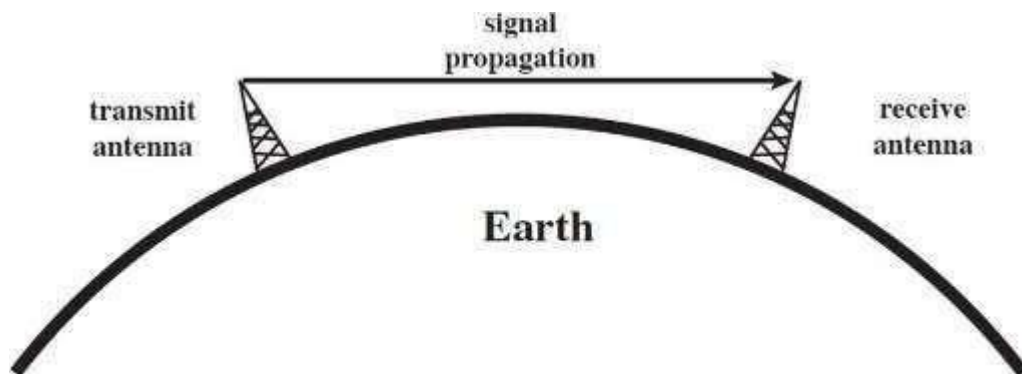

Line-of-sight (LOS) propagation (above 30 MHz)

The figure depicts this mode of propagation very clearly. The line-of-sight propagation will not be smooth if there occurs any obstacle in its transmission path. As the signal can travel only to lesser distances in this mode, this transmission is used for **infrared** or **microwave transmissions**.

GroundWave Propagation

Ground wave propagation of the wave follows the contour of earth. Such a wave is called as **direct wave**. The wave sometimes bends due to the Earth's magnetic field and gets reflected to the receiver. Such a wave can be termed as **reflected wave**.

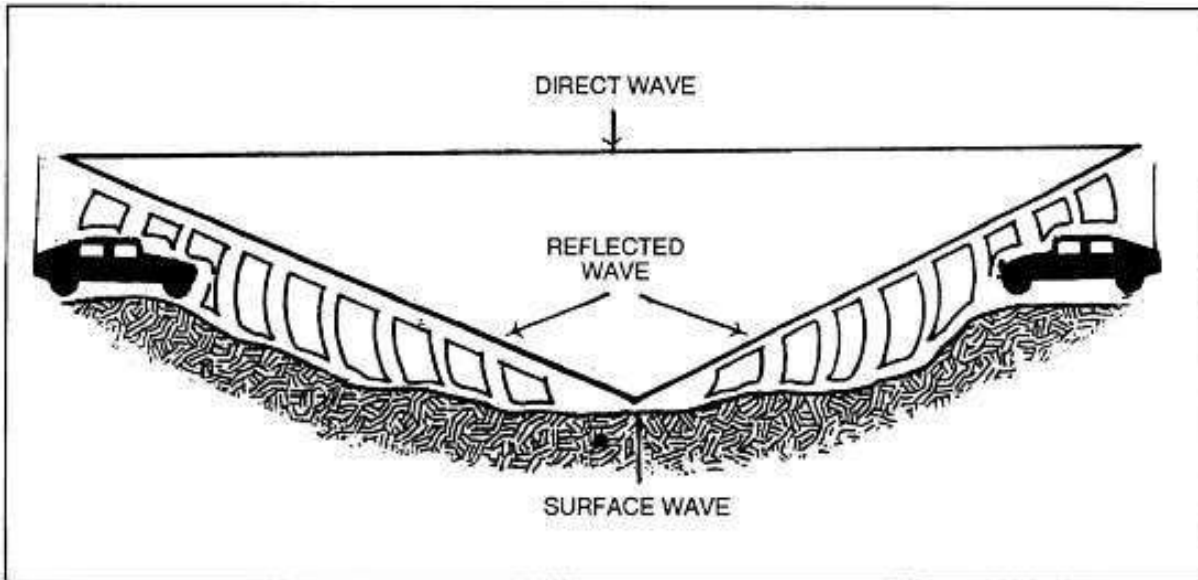
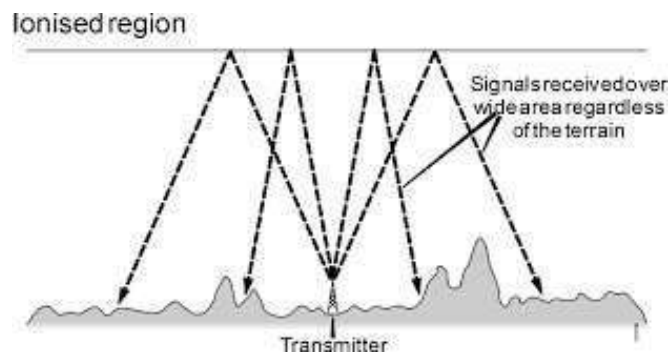

Figure Components of ground wave.

The above figure depicts ground wave propagation. The wave when propagates through the Earth's atmosphere is known as **ground wave**. The direct wave and reflected wave together contribute the signal at the receiver station. When the wave finally reaches the receiver, the lags are cancelled out. In addition, the signal is filtered to avoid distortion and amplified for clear output.

SkyWave Propagation

Sky wave propagation is preferred when the wave has to travel a longer distance. Here the wave is projected onto the sky and it is again reflected back onto the earth.



The **sky wave propagation** is well depicted in the above picture. Here the waves are shown to be transmitted from one place and where it is received by many receivers. Hence, it is an example of broadcasting.

The waves, which are transmitted from the transmitter antenna, are reflected from the ionosphere. It consists of several layers of charged particles ranging in altitude from 30-250 miles above the surface of the earth. Such a travel of the wave from transmitter to the ionosphere and from there to the receiver on Earth is known as **Sky Wave Propagation**. Ionosphere is the ionized layer around the Earth's atmosphere, which is suitable for sky wave propagation.

Ionosphere and its Layers

Earth's atmosphere has several layers. These layers play an important role in the wireless communication. These are mainly classified into three layers.

Troposphere

This is the layer of the earth, which lies just above the ground. We, the flora and fauna live in this layer. The ground wave propagation and LOS propagation take place here.

Stratosphere

This is the layer of the earth, which lies above Troposphere. The birds fly in this region. The airplanes travel in this region. Ozone layer is also present in this region. The ground wave propagation and LOS propagation takes place here.

Ionosphere

This is the upper layer of the Earth's atmosphere, where ionization is appreciable. The energy radiated by the Sun, not only heats this region, but also produces positive and negative ions. Since the Sun constantly radiates UV rays and air pressure is low, this layer encourages ionization of particles.

Importance of Ionosphere

The ionosphere layer is a very important consideration in the phase of wave propagation because of the following reasons-

- The layer below ionosphere has higher amount of air particles and lower UV radiation. Due to this, more collisions occur and ionization of particles is minimum and not constant.
- The layer above ionosphere has very low amount of air particles and density of ionization is also quite low. Hence, ionization is not proper.
- The ionosphere has good composition of UV radiation and average air density that does not affect the ionization. Hence, this layer has most influence on the Sky wave propagation.

The ionosphere has different gases with different pressures. Different ionizing agents ionize these at different heights. As various levels of ionization are done at each level, having different gases, few layers with different properties are formed in the ionosphere.

The layers of ionosphere can be studied from the following figure.

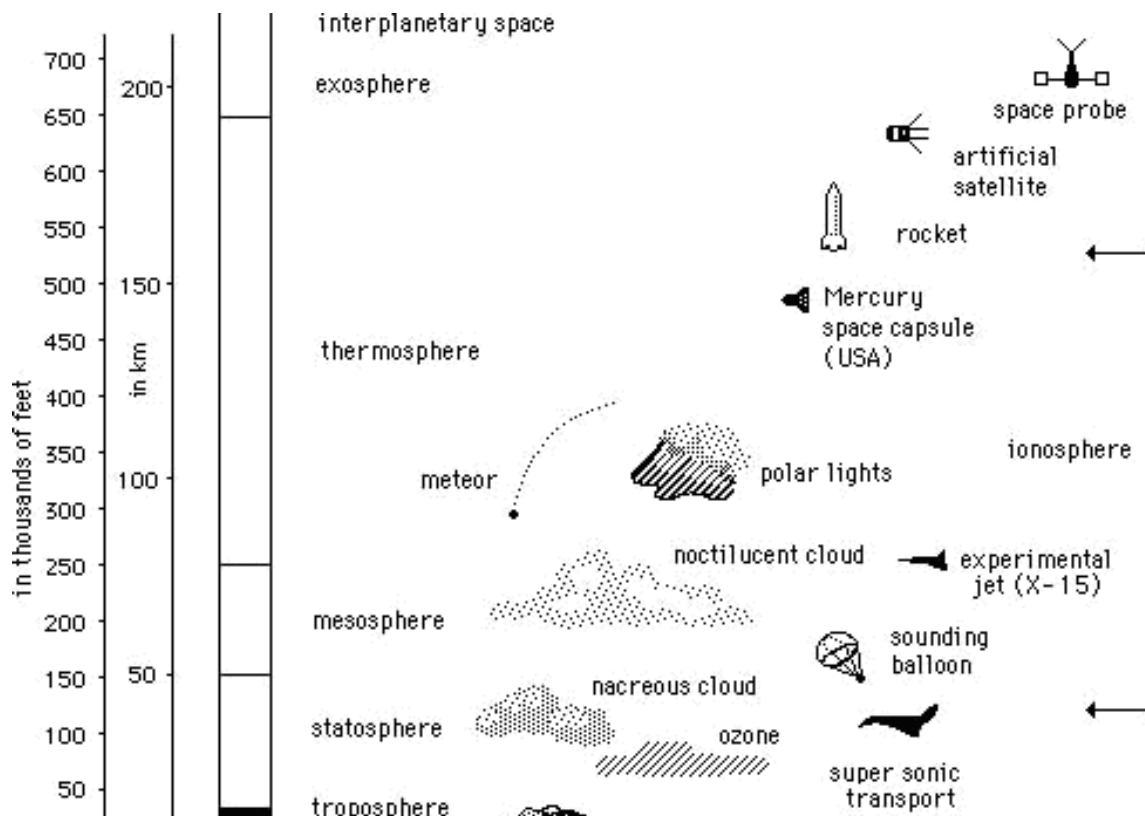

The number of layers, their heights, the amount of sky wave that can be bent will vary from day to day, month to month and year to year. For each such layer, there is a frequency, above which if the wave is sent upward vertically, it penetrates through the layer.

The function of these layers depends upon the time of the day, i.e., day time and night time. There are three principal layers- E, F1 and F2 during day time. There is another layer called D layer, which lies below E layer. This layer is at 50 to 90kms above the troposphere. This D layer is responsible for the day time attenuation of HF waves. During night time, this D layer almost vanishes out and the F1 and F2 layers combine together to form F layer. Hence, there are only two **layers E and F** present at the **night time**.

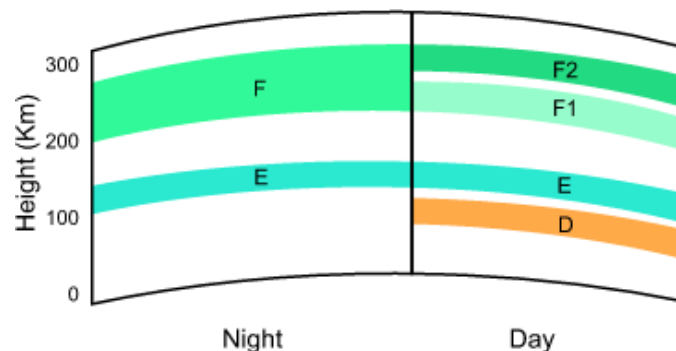

Terms in Wave Propagation

In the process of propagation of a wave, there are few terms which we come across quite often. Let us discuss about these terms one by one.

Virtual Height

When a wave is refracted, it is bent down gradually, but not sharply. However, the path of incident wave and reflected wave are same if it is reflected from a surface located at a greater height of this layer. Such a greater height is termed as **virtual height**.

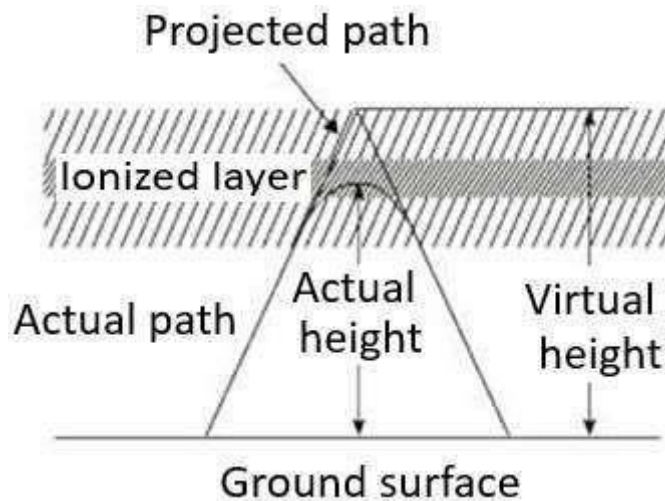

The figure clearly distinguishes the **virtual height** (height of wave, supposed to be reflected) and **actual height** (the refracted height). If the virtual height is known, the angle of incidence can be found.

Critical Frequency

Critical frequency for a layer determines the highest frequency that will be returned down to the earth by that layer, after having been beamed by the transmitter, straight up into the sky.

The rate of ionization density, when changed conveniently through the layers, the wave will be bent downwards. The maximum frequency that gets bent and reaches the receiver station with minimum attenuation, can be termed as **critical frequency**. This is denoted by f_c .

Multi-path

For the frequencies above 30 MHz, the sky wave propagation exists. Signal multipath is the common problem for the propagation of electromagnetic waves going through Sky wave. The wave, which is reflected from the ionosphere, can be called as a **hop** or **skip**. There can be a number of hops for the signal as it may move back and forth from the ionosphere and earth surface many times. Such a movement of signal can be termed as **multipath**.

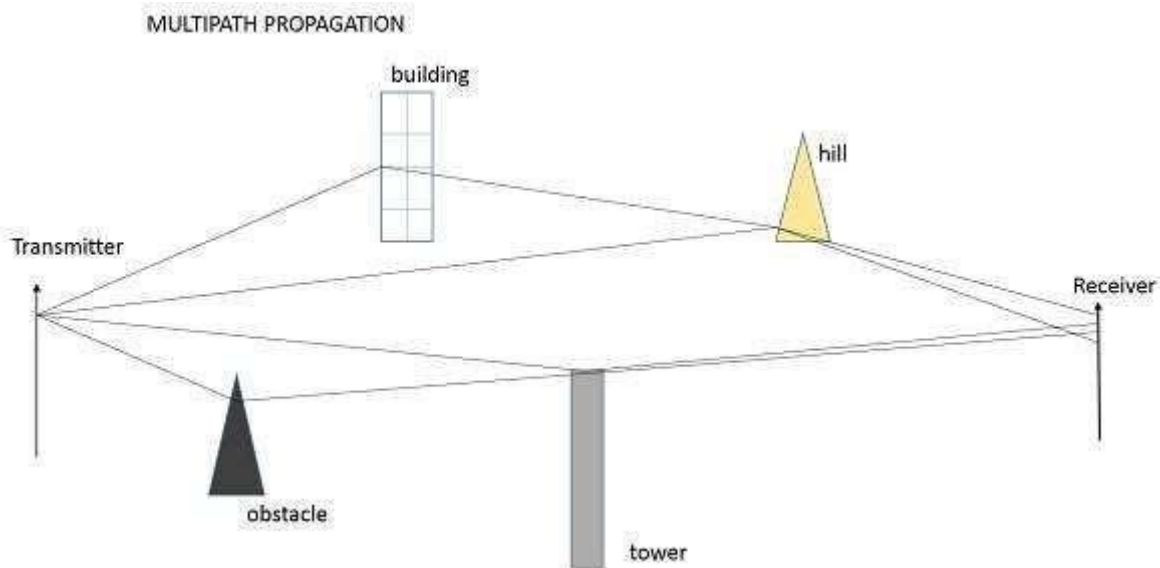

The above figure shows an example of multi-path propagation. Multipath propagation is a term, which describes the multiple paths a signal travels to reach the destination. These paths include a number of hops. The paths may be the results of reflection, refraction or even diffraction. Finally, when the signal from such different paths gets to the receiver, it carries propagation delay, additional noise, phase differences etc., which decrease the quality of the received output.

Fading

The decrease in the quality of the signal can be termed as **fading**. This happens because of atmospheric effects or reflections due to multipath.

Fading refers to the variation of the signal strength with respect to time/distance. It is widely prevalent in wireless transmissions. The most common causes of fading in the wireless environment are multipath propagation and mobility (of objects as well as the communicating devices).

Skip Distance

The measurable distance on the surface of the Earth from transmitter to receiver, where the signal reflected from the ionosphere can reach the receiver with minimum hops or skips, is known as **skip distance**.

Maximum Usable Frequency(MUF)

The **Maximum Usable Frequency (MUF)** is the highest frequency delivered by the transmitter regardless of the power of the transmitter. The highest frequency, which is reflected from the ionosphere to the receiver is called as **critical frequency, f_c** .

$$MUF = \frac{\text{Critical frequency}}{\cos \theta} = f_c \sec \theta$$

Optimum Working Frequency(OWF)

The frequency, which is being used mostly for a particular transmission and which has been predicted to be used over a particular period of time, over a path, is termed as **Optimum Working Frequency (OWF)**.

Inter Symbol Interference

Inter symbol interference (ISI) occurs more commonly in communication system. This is the main reason for signal multipath also. When signals arrive at the receiving stations via different propagation paths, they cancel out each other, which is known as the phenomenon of **signal fading**. Here, it should be remembered that the signals cancel out themselves in vector way.

Skin Depth

Electromagnetic waves are not suitable for underwater propagations. However, they can propagate under water provided we make the frequency of propagation extremely low. The attenuation of electromagnetic waves under water is expressed in terms of skin depth. **Skin depth** is defined as the distance at which the signal is attenuated by $1/e$. It is a measure of depth to which an EM wave can penetrate. Skin depth is represented as δ (delta).

Duct Propagation

At a height of around 50 mts from the troposphere, a phenomenon exists; the temperature increases with the height. In this region of troposphere, the higher frequencies or microwave frequencies tend to refract back into the Earth's atmosphere, instead of shooting into ionosphere, to reflect. These waves propagate around the curvature of the earth even up to a distance of 1000km.

This refraction goes on continuing in this region of troposphere. This can be termed as

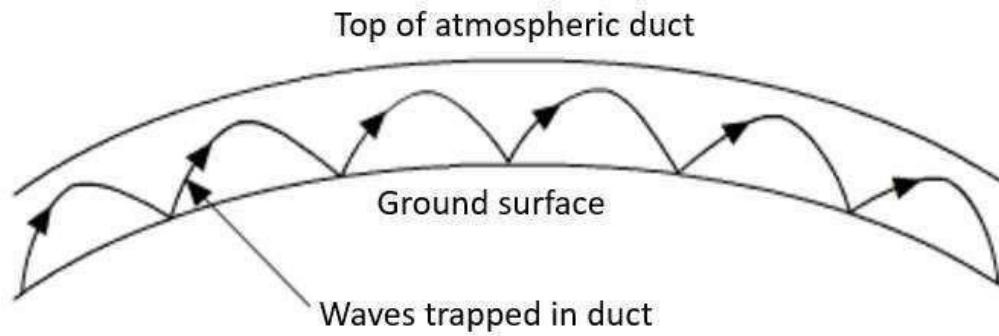

The above image shows the process of **Duct Propagation**. The main requirement for the duct formation is the temperature inversion. The increase of temperature with height, rather than the decrease in the temperature is known as the phenomenon of temperature inversion.

We have discussed the important parameters, which we come across in wave propagation. The waves of higher frequencies are transmitted and received using this wave propagation technique.

Antenna – Basic Terms

Antenna – Fundamentals

A person, who needs to convey a thought, an idea or a doubt, can do so by **voice communication**.

The following illustration shows two individuals communicating with each other. Here, communication takes place through sound waves. However, if two people want to communicate who are at longer distances, then we have to convert these sound waves into electromagnetic waves. The device, which converts the required information signal into electromagnetic waves, is known as an **Antenna**.

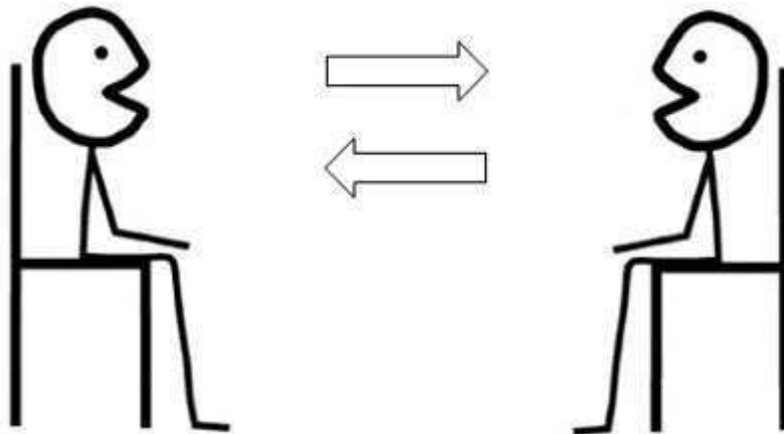

What is an Antenna

An Antenna is a transducer, which converts electrical power into electromagnetic waves and vice versa.

An Antenna can be used either as a **transmitting antenna** or a **receiving antenna**.

- A **transmitting antenna** is one, which converts electrical signals into electromagnetic waves and radiates them.
- A **receiving antenna** is one, which converts electromagnetic waves from the received beam into electrical signals.
- In two-way communication, the same antenna can be used for both transmission and reception.

Antenna can also be termed as an **Aerial**. Plural of it is, **antennae** or **antennas**. Now-a-days, antennas have undergone many changes, in accordance with their size and shape. There are many types of antennas depending upon their wide variety of applications.

Following pictures are examples of different types of Antennas.



In this chapter, you are going to learn the basic concepts of antenna, specifications and different types of antennas.

Need of Antenna

In the field of communication systems, whenever the need for wireless communication arises, there occurs the necessity of an antenna. **Antenna** has the capability of sending or receiving the electromagnetic waves for the sake of communication, where you cannot expect to lay down a wiring system. The following scenario explains this.

Scenario

In order to contact a remote area, the wiring has to be laid down throughout the whole route along the valleys, the mountains, the tedious paths, the tunnels etc., to reach the remote location. The evolution of wireless technology has made this whole process very simple. Antenna is the key element of this wireless technology.



In the above image, the antennas help the communication to be established in the whole area, including the valleys and mountains. This process would obviously be easier than laying a wiring system throughout the area.

Radiation Mechanism of an Antenna

The sole functionality of an antenna is **power radiation** or reception. Antenna (whether it transmits or receives or does both) can be connected to the circuitry at the station through a transmission line. The functioning of an antenna depends upon the radiation mechanism of a transmission line.

A conductor, which is designed to carry current over large distances with minimum losses, is termed as a **transmission line**. For example, a wire, which is connected to an antenna. A transmission line conducting current with uniform velocity, and the line being a straight one with infinite extent, **radiates no power**.

For a transmission line, to become a waveguide or to radiate power, has to be processed as such

- If the power has to be radiated, though the current conduction is with uniform velocity, the wire or transmission line should be bent, truncated or terminated.
- If this transmission line has current, which accelerates or decelerates with a time-varying constant, then it radiates the power even though the wire is straight.
- The device or tube, if bent or terminated to radiate energy, then it is called as **waveguide**. These are especially used for the microwave transmission or reception.

This can be well understood by observing the following diagram-

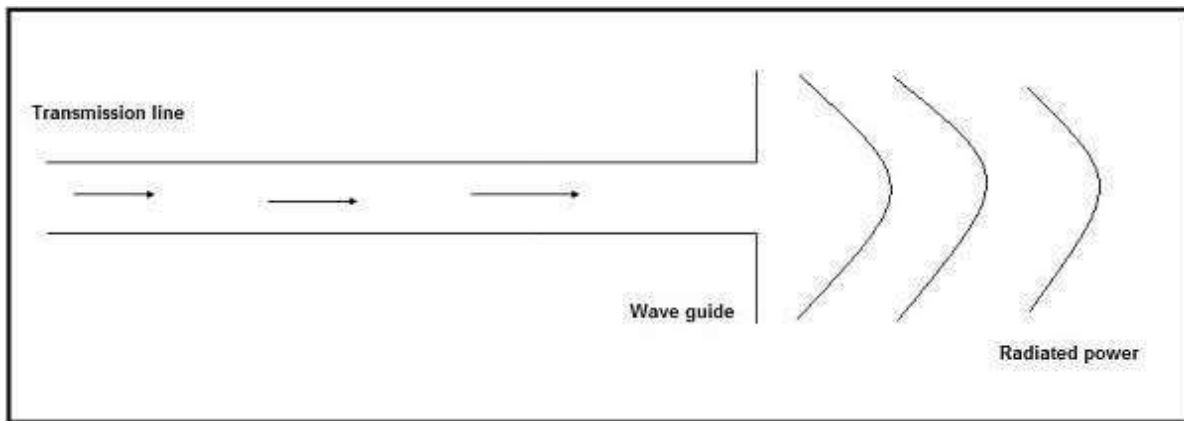

The above diagram represents a waveguide, which acts as an antenna. The power from the transmission line travels through the waveguide which has an aperture, to radiate the energy.

Basic Types of Antennas

Antennas may be divided into various types depending upon-

- The physical structure of the antenna.
- The frequency ranges of operation.
- The mode of applications etc.

Physical structure

Following are the types of antennas according to the physical structure. You will learn about these antennas in later chapters.

- Wire antennas
- Aperture antennas
- Reflector antennas
- Lens antennas
- Micro strip antennas
- Array antennas

Frequency of operation

Following are the types of antennas according to the frequency of operation.

- Very Low Frequency (VLF)
- Low Frequency (LF)
- Medium Frequency (MF)
- High Frequency (HF)
- Very High Frequency (VHF)

- Ultra High Frequency (UHF)
- Super High Frequency (SHF)
- Micro wave
- Radio wave

Mode of Applications

Following are the types of antennas according to the modes of applications-

- Point-to-point communications
- Broadcasting applications
- Radar communications
- Satellite communications

Antenna – Basic Parameters

The basic communication parameters are discussed in this chapter to have a better idea about the wireless communication using antennas. The wireless communication is done in the form of waves. Hence, we need to have a look at the properties of waves in the communications.

In this chapter, we are going to discuss about the following parameters-

- Frequency
- Wavelength
- Impedance matching
- VSWR & reflected power
- Bandwidth
- Percentage bandwidth
- Radiation intensity

Now, let us learn them in detail.

Frequency

According to the standard definition, "The rate of repetition of a wave over a particular period of time, is called as **frequency**."

Simply, frequency refers to the process of how often an event occurs. A periodic wave repeats itself after every '**T**' seconds (time period). **Frequency** of periodic wave is nothing but the reciprocal of time period (T).

Mathematical Expression

Mathematically, it is written as shown below.

$$f = \frac{1}{T}$$

Where

- **f** is the frequency of periodic wave.
- **T** is the time period at which the wave repeats.

Units

The unit of frequency is **Hertz**, abbreviated as **Hz**.

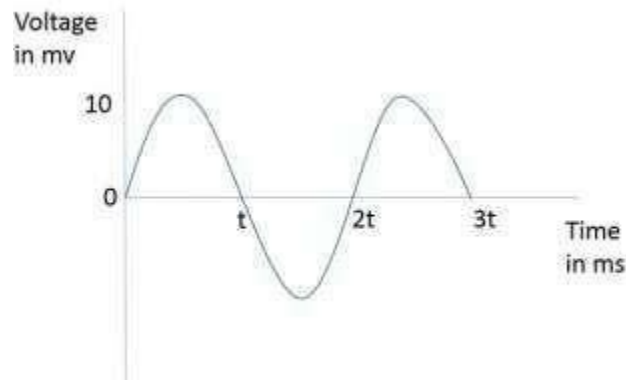

The figure given above represents a sine wave, which is plotted here for Voltage in millivolts against time in milliseconds. This wave repeats after every $2t$ milliseconds. So, time period, $T=2t$ milliseconds and frequency, $f = \frac{1}{2t} \text{ KHz}$.

Wavelength

According to the standard definition, "The distance between two consecutive maximum points (crests) or between two consecutive minimum points (troughs) is known as the **wavelength**."

Simply, the distance between two immediate positive peaks or two immediate negative peaks is nothing but the length of that wave. It can be termed as the **Wavelength**.

The following figure shows a periodic waveform. The **wavelength (λ)** and amplitude are denoted in the figure. The higher the frequency, the lesser will be the wavelength and vice versa.

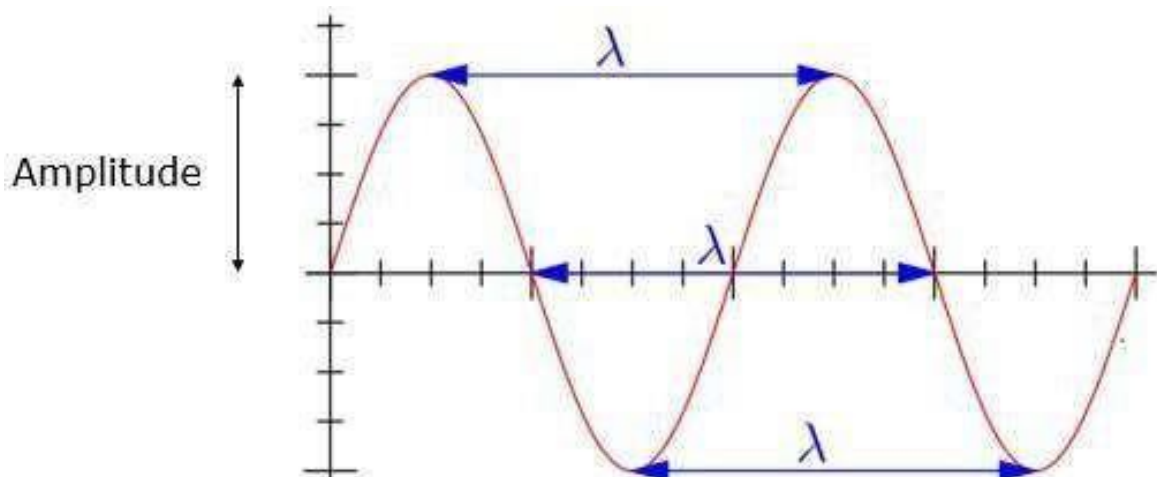

Mathematical Expression

The formula for wavelength is,

$$\lambda = \frac{c}{f}$$

Where-

- λ is the wavelength
- c is the speed of light (3×10^8 meters/second)
- f is the frequency

Units

The wavelength λ is expressed in the units of length such as meters, feet or inches. The commonly used term is **meters**.

Impedance Matching

According to the standard definition, "The approximate value of impedance of a transmitter, when equals the approximate value of the impedance of a receiver, or vice versa, it is termed as **Impedance matching**."

Impedance matching is necessary between the antenna and the circuitry. The impedance of the antenna, the transmission line, and the circuitry should match so that **maximum power transfer** takes place between the antenna and the receiver or the transmitter.

Necessity of Matching

A resonant device is one, which gives better output at certain narrow band of frequencies. Antennas are such **resonant devices** whose impedance if matched, delivers a better output.

- The power radiated by an antenna, will be effectively radiated, if the **antenna impedance** matches the free space impedance.
- For a **receiver antenna**, antenna's output impedance should match with the input impedance of the receiver amplifier circuit.
- For a **transmitter antenna**, antenna's input impedance should match with transmitter amplifier's output impedance, along with the transmission line impedance.

Units

The unit of impedance (**Z**) is **Ohms**.

VSWR& ReflectedPower

According to the standard definition, "The ratio of the maximum voltage to the minimum voltage in a standing wave is known as **Voltage Standing Wave Ratio.**"

If the impedance of the antenna, the transmission line and the circuitry do not match with each other, then the power will not be radiated effectively. Instead, some of the power is reflected back.

The key features are-

- The term, which indicates the impedance mismatch is **VSWR**.
- **VSWR** stands for Voltage Standing Wave Ratio. It is also called as **SWR**.
- The higher the impedance mismatch, the higher will be the value of **VSWR**.
- The ideal value of VSWR should be 1:1 for effective radiation.
- Reflected power is the power wasted out of the forward power. Both reflected power and VSWR indicate the same thing.

Bandwidth

According to the standard definition, "A band of frequencies in a wavelength, specified for the particular communication, is known as **bandwidth.**"

The signal when transmitted or received, is done over a range of frequencies. This particular range of frequencies are allotted to a particular signal, so that other signals may not interfere in its transmission.

- **Bandwidth** is the band of frequencies between the higher and lower frequencies over which a signal is transmitted.
- The bandwidth once allotted, cannot be used by others.
- The whole spectrum is divided into bandwidths to allot to different transmitters.

The bandwidth, which we just discussed can also be called as **Absolute Bandwidth**.

PercentageBandwidth

According to the standard definition, "The ratio of absolute bandwidth to the center frequency of that bandwidth can be termed as **percentage bandwidth.**"

The particular frequency within a frequency band, at which the signal strength is maximum, is called as **resonant frequency**. It is also called as **center frequency (fc)** of the band.

- The higher and lower frequencies are denoted as **f_H** and **f_L** respectively.
- The absolute bandwidth is given by- **f_H - f_L**.
- To know how wider the bandwidth is, either **fractional bandwidth** or **percentage bandwidth** has to be calculated.

Mathematical Expression

The **Percentage bandwidth** is calculated to know how much frequency variation either a component or a system can handle.

$$\text{Percentage bandwidth} = \frac{\text{absolute bandwidth}}{\text{center frequency}} = \frac{(f_H - f_L)}{f_c}$$

Where

- f_H is higher frequency
- f_L is lower frequency
- f_c is center frequency

The higher the percentage bandwidth, the wider will be the bandwidth of the channel.

Radiation Intensity

“**Radiation intensity** is defined as the power per unit solid angle”

Radiation emitted from an antenna which is more intense in a particular direction, indicates the maximum intensity of that antenna. The emission of radiation to a maximum possible extent is nothing but the radiation intensity.

Mathematical Expression

Radiation Intensity is obtained by multiplying the power radiated with the square of the radial distance.

$$U = r^2 \times W_{rad}$$

Where

- U is the radiation intensity
- r is the radial distance
- W_{rad} is the power radiated.

The above equation denotes the radiation intensity of an antenna. The function of radial distance is also indicated as Φ .

Units

The unit of radiation intensity is **Watts/steradian** or **Watts/radian²**.

Antenna – Parameters

Radiation intensity of an antenna is closely related to the direction of the beam focused and the efficiency of the beam towards that direction. In this chapter, let us have a look at the terms that deal with these topics.

Directivity

According to the standard definition, "The ratio of maximum radiation intensity of the subject antenna to the radiation intensity of an isotropic or reference antenna, radiating the same total power is called the **directivity**."

An Antenna radiates power, but the direction in which it radiates matters much. The antenna, whose performance is being observed, is termed as **subject antenna**.

Its **radiation intensity** is focused in a particular direction, while it is transmitting or receiving. Hence, the antenna is said to have its **directivity** in that particular direction.

- The ratio of radiation intensity in a given direction from an antenna to the radiation intensity averaged over all directions, is termed as directivity.
- If that particular direction is not specified, then the direction in which maximum intensity is observed, can be taken as the directivity of that antenna.
- The directivity of a non-isotropic antenna is equal to the ratio of the radiation intensity in a given direction to the radiation intensity of the isotropic source.

Mathematical Expression

The radiated power is a function of the angular position and the radial distance from the circuit. Hence, it is expressed by considering both the terms θ and ϕ .

The mathematical expression for directivity is as follows-

$$\text{Directivity} = \frac{\text{Maximum radiation intensity of subject antenna}}{\text{Radiation intensity of an isotropic antenna}}$$

$$D = \frac{\Phi(\theta, \phi)_{\max} (\text{from subject antenna})}{\Phi_0 (\text{from an isotropic antenna})}$$

Where

- $\Phi(\theta, \phi)_{\max}$ is the maximum radiation intensity of subject antenna.
- Φ_0 is the radiation intensity of an isotropic antenna (antenna with zero losses).

Aperture Efficiency

According to the standard definition, "**Aperture efficiency** of an antenna, is the ratio of the effective radiating area (or effective area) to the physical area of the aperture."

An antenna has an aperture through which the power is radiated. This radiation should be effective with minimum losses. The physical area of the aperture should also be taken into consideration, as the effectiveness of the radiation depends upon the area of the aperture, physically on the antenna.

Mathematical Expression

The mathematical expression for aperture efficiency is as follows-

$$\epsilon_A = \frac{A_{eff}}{A_p}$$

where

- ϵ_A is Aperture Efficiency.
- A_{eff} is effective area.
- A_p is physical area.

Antenna Efficiency

According to the standard definition, "**Antenna Efficiency** is the ratio of the radiated power of the antenna to the input power accepted by the antenna."

Simply, an Antenna is meant to radiate power given at its input, with minimum losses. The efficiency of an antenna explains how much an antenna is able to deliver its output effectively with minimum losses in the transmission line.

This is otherwise called as **Radiation Efficiency Factor** of the antenna.

Mathematical Expression

The mathematical expression for antenna efficiency is given below-

$$\eta_e = \frac{P_{rad}}{P_{input}}$$

Where

- η_e is the antenna efficiency.
- P_{rad} is the power radiated.
- P_{input} is the input power for the antenna.

Gain

According to the standard definition, "**Gain** of an antenna is the ratio of the radiation intensity in a given direction to the radiation intensity that would be obtained if the power accepted by the antenna were radiated isotropically."

Simply, gain of an antenna takes the directivity of antenna into account along with its effective performance. If the power accepted by the antenna was radiated isotropically (that means in all directions), then the radiation intensity we get can be taken as a referential.

- The term **antenna gain** describes how much power is transmitted in the direction of peak radiation to that of an isotropic source.
- **Gain** is usually measured in **dB**.
- Unlike directivity, antenna gain takes the losses that occur also into account and hence focuses on the efficiency.

Mathematical Expression

The equation of gain, G is as shown below

$$G = \eta_e D$$

Where

- **G** is gain of the antenna.
- η_e is the antenna's efficiency.
- **D** is the directivity of the antenna.

Units

The unit of gain is **decibels** or simply **dB**.

Antenna—Near and Far Fields

After the antenna parameters discussed in the previous chapter, another important topic of consideration is the near field and the far field regions of the antenna.

The radiation intensity when measured nearer to the antenna, differs from what is away from the antenna. Though the area is away from the antenna, it is considered effective, as the radiation intensity is still high there.

Near Field

The field, which is nearer to the antenna, is called as **near-field**. It has an inductive effect and hence it is also known as **inductive field**, though it has some radiation components.

Far field

The field, which is far from the antenna, is called as **far-field**. It is also called as **radiation field**, as the radiation effect is high in this area. Many of the antenna parameters along with the antenna directivity and the radiation pattern of the antenna are considered in this region only.

Field Pattern

The field distribution can be quantifying in terms of field intensity is referred to as field pattern. That means, the radiated power from the antenna when plotted, is expressed in terms of electric field, E (v/m). Hence, it is known as **field pattern**. If it is quantified in terms of power (W), then it is known as **power pattern**.

The graphical distribution of radiated field or power will be as a function of

- spatial angles (θ, ϕ) for far-field.
- spatial angles (θ, ϕ) and radial distance(r) for near-field.

The distribution of near and far field regions can be well understood with the help of a diagram.

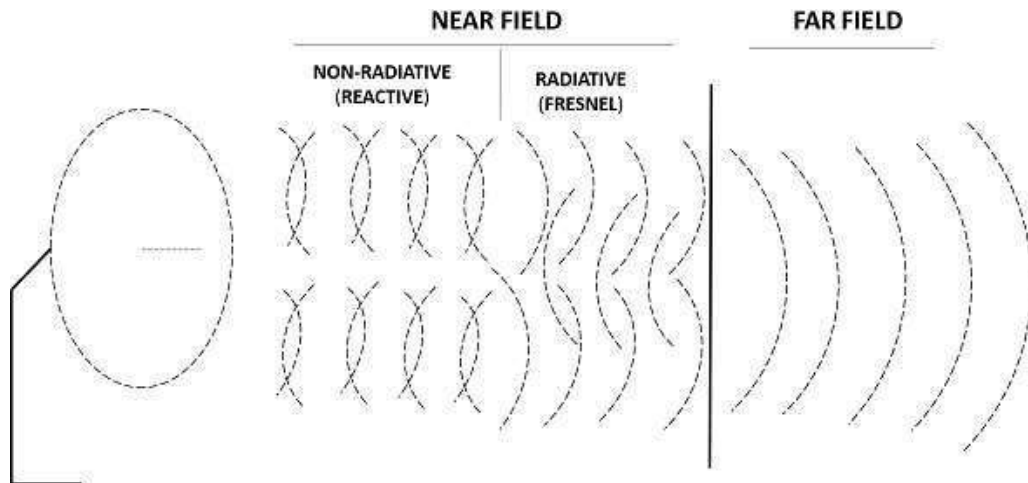

The field pattern can be classified as-

- Reactive near-field region and Radiating near-field region – both termed as near-field.
- Radiating far-field region – simply called as far-field.

The field, which is very near to the antenna is **reactive near field** or **non-radiative field** where the radiation is not pre-dominant. The region next to it can be termed as **radiating near field** or **Fresnel's field** as the radiation predominates and the angular field distribution, depends on the physical distance from the antenna.

The region next to it is **radiating far-field** region. In this region, field distribution is independent of the distance from antenna. The effective radiation pattern is observed in this region.

Antenna – Radiation Pattern

Radiation is the term used to represent the emission or reception of wave front at the antenna, specifying its strength. In any illustration, the sketch drawn to represent the radiation of an antenna is its **radiation pattern**. One can simply understand the function and directivity of an antenna by having a look at its radiation pattern.

The power when radiated from the antenna has its effect in the near and far field regions.

- Graphically, radiation can be plotted as a function of **angular position** and **radial distance** from the antenna.
- This is a mathematical function of radiation properties of the antenna represented as a function of spherical co-ordinates, $E(\theta, \phi)$ and $H(\theta, \phi)$.

Radiation Pattern

The energy radiated by an antenna is represented by the **Radiation pattern** of the antenna. Radiation Patterns are diagrammatical representations of the distribution of radiated energy into space, as a function of direction.

Let us look at the pattern of energy radiation.

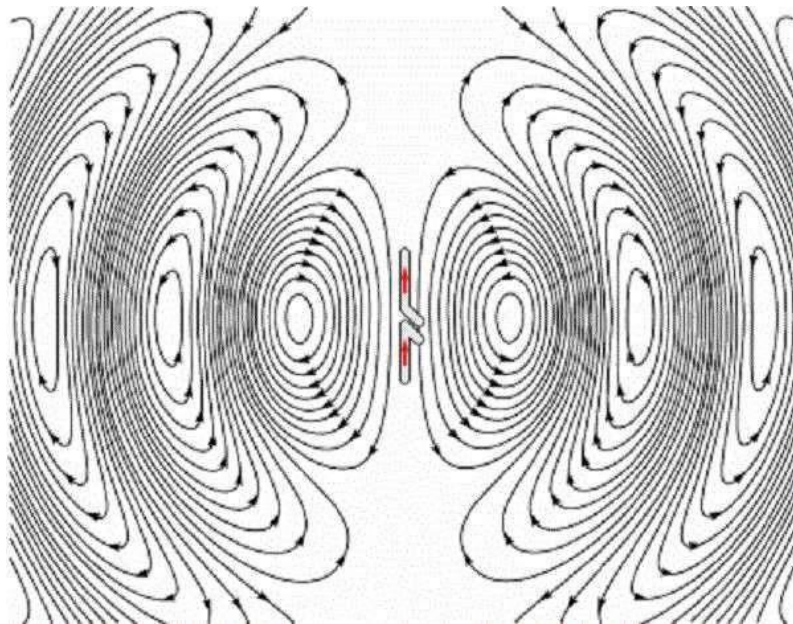

The figure given above shows radiation pattern of a dipole antenna. The energy being radiated is represented by the patterns drawn in a particular direction. The arrows represent directions of radiation.

The radiation patterns can be field patterns or power patterns.

- The **field patterns** are plotted as a function of electric and magnetic fields. They are plotted on logarithmic scale.

- The **power patterns** are plotted as a function of square of the magnitude of electric and magnetic fields. They are plotted on logarithmic or commonly on dB scale.

Radiation Pattern in 3D

The radiation pattern is a three-dimensional figure and represented in spherical coordinates (r, θ, Φ) assuming its origin at the center of spherical coordinate system. It looks like the following figure-

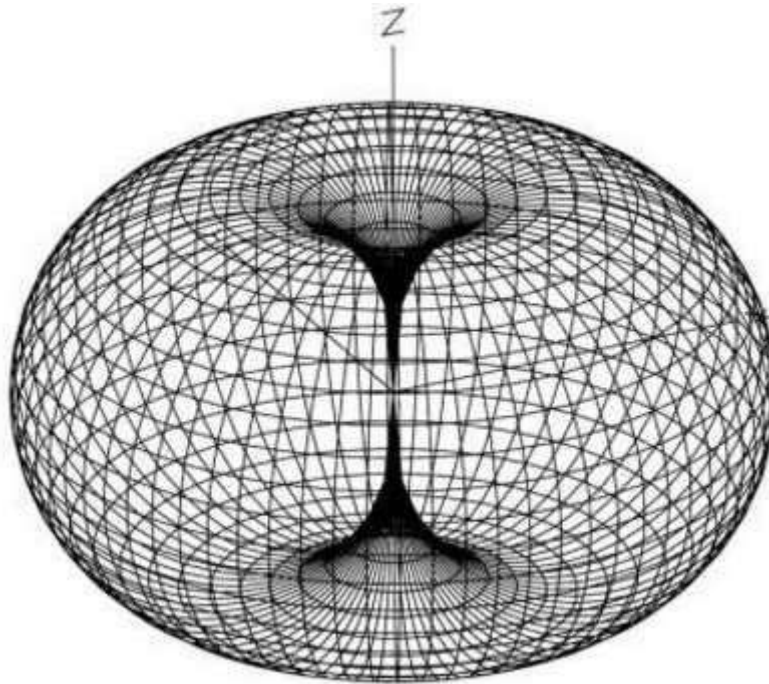

The given figure is a three dimensional radiation pattern for an **Omnidirectional pattern**. This clearly indicates the three co-ordinates (x, y, z) .

Radiation Pattern in 2D

Two-dimensional pattern can be obtained from three-dimensional pattern by dividing it into horizontal and vertical planes. These resultant patterns are known as **Horizontal pattern** and **Vertical pattern** respectively.

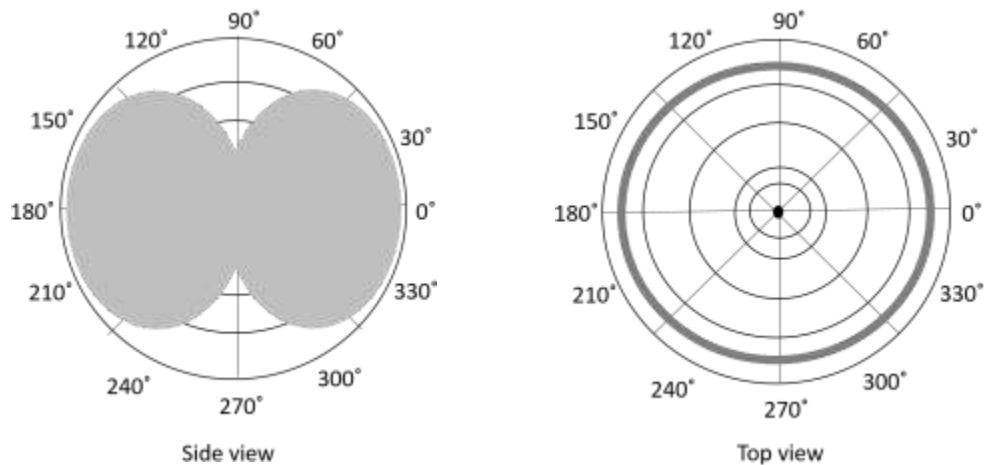

The figures show the Omni directional radiation pattern in H and V planes as explained above. H-plane represents the Horizontal pattern, whereas V-plane represents the Vertical pattern.

Lobe Formation

In the representation of radiation pattern, we often come across different shapes, which indicate the major and minor radiation areas, by which the **radiation efficiency** of the antenna is known.

To have a better understanding, consider the following figure, which represents the radiation pattern of a dipole antenna.

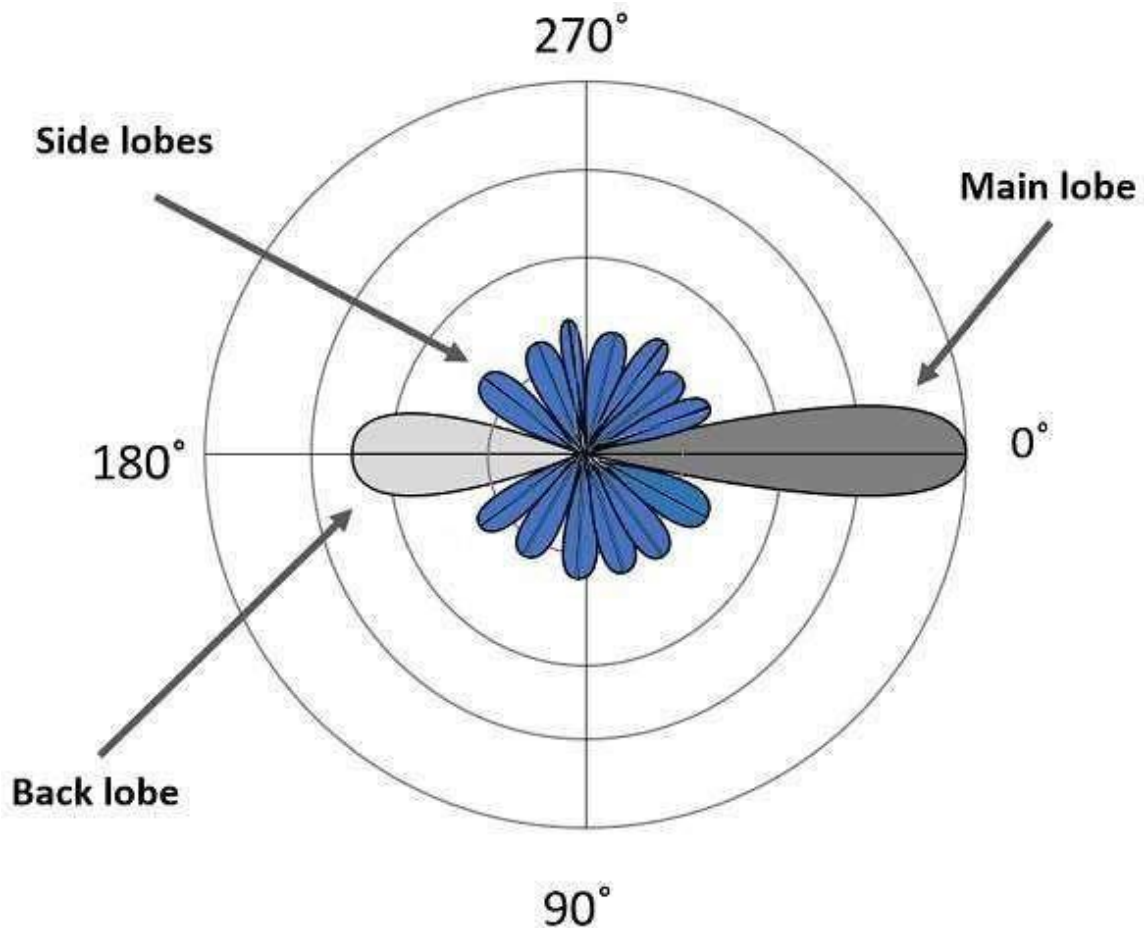

Here, the radiation pattern has main lobe, side lobes and back lobe.

- The major part of the radiated field, which covers a larger area, is the **main lobe** or **major lobe**. This is the portion where maximum radiated energy exists. The direction of this lobe indicates the directivity of the antenna.
- The other parts of the pattern where the radiation is distributed side wards are known as **side lobes** or **minor lobes**. These are the areas where the power is wasted.
- There is other lobe, which is exactly opposite to the direction of main lobe. It is known as **back lobe**, which is also a minor lobe. A considerable amount of energy is wasted even here.

Example

If the antennas used in radar systems produce side lobes, target tracing becomes very difficult. This is because, false targets are indicated by these side lobes. It is messy to trace out the real ones and to identify the fake ones. Hence, **elimination of these side lobes** is must, in order to improve the performance and save the energy.

Remedy

The radiated energy, which is being wasted in such forms needs to be utilized. If these minor lobes are eliminated and this energy is diverted into one direction (that is towards the major lobe), then the **directivity** of the antenna gets increased which leads to antenna's better performance.

Types of Radiation patterns

The common types of Radiation patterns are-

- Omni-directional pattern (also called non-directional pattern): The pattern usually has a doughnut shape in three-dimensional view. However, in two-dimensional view, it forms a figure-of-eight pattern.
- Pencil-beam pattern: The beam has a sharp directional pencil shaped pattern.
- Fan-beam pattern: The beam has a fan-shaped pattern.
- Shaped beam pattern: The beam, which is non-uniform and patternless is known as shaped beam.

A referential point for all these types of radiation is the isotropic radiation. It is important to consider the isotropic radiation even though it is impractical.

Antenna – Isotropic Radiation

In the previous chapter, we have gone through the radiation pattern. To have a better analysis regarding the radiation of an antenna, a referential point is necessary. The radiation of an isotropic antenna, fills this space.

Definition

Isotropic radiation is the radiation from a point source, radiating uniformly in all directions, with same intensity regardless of the direction of measurement.

The improvement of radiation pattern of an antenna is always assessed using the isotropic radiation of that antenna. If the radiation is equal in all directions, then it is known as **isotropic radiation**.

- The point source is an example of isotropic radiator. However, this isotropic radiation is practically impossible, because every antenna radiates its energy with some directivity.
- The isotropic radiation is nothing but **Omni-directional radiation**.
- It has a doughnut-shaped pattern when viewed in 3D and a figure-of-eight pattern when viewed in 2D.

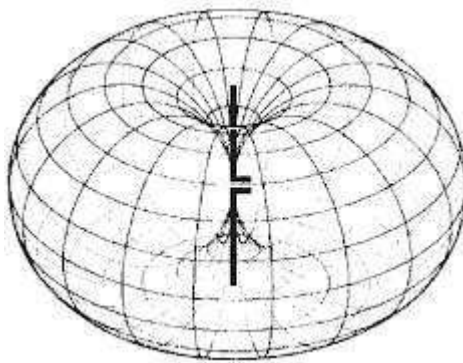

Figure 1

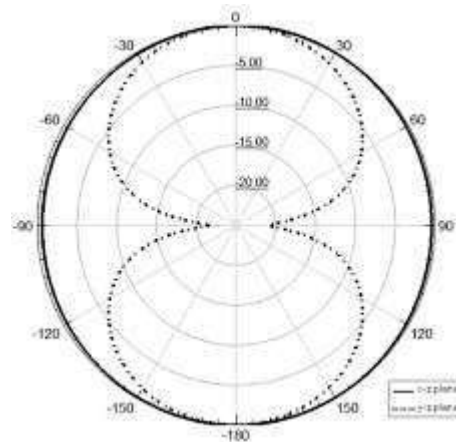

Figure 2

The figures given above show the radiation pattern of an isotropic or Omni-directional pattern. Figure 1 illustrates the doughnut shaped pattern in 3D and Figure 2 illustrates the figure-of-eight pattern in 2D.

Gain

The isotropic radiator has unity gain, which means having a gain factor of 1 in all directions. In terms of dB, it can be called as 0dB gain (zero loss).

Equivalent Isotropic Radiated Power

According to the standard definition, "The amount of power that an isotropical antenna radiates to produce the peak power density observed in the direction of maximum antenna gain, is called as **Equivalent Isotropic Radiated Power.**"

If the radiated energy of an antenna is made to concentrate on one side or a particular direction, where the radiation is equivalent to that antenna's isotropic radiated power, such a radiation would be termed as EIRP i.e. Equivalent Isotropic Radiated Power.

Gain

Though isotropic radiation is an imaginary one, it is the best an antenna can give. The gain of such antenna will be 3dBi where 3dB is a factor of 2 and 'i' represents factor of isotropic condition.

If the radiation is focused in certain angle, then EIRP increases along with the antenna gain. Gain of the antenna is best achieved by focusing the antenna in certain direction.

Effective Radiated Power

If the radiated power is calculated by taking half-wave dipole as the reference, rather than an isotropic antenna, then it can be termed as **ERP (Effective Radiated Power).**

$$ERP(dBW) = EIRP(dBW) - 2.15 dBi$$

If EIRP is known, then ERP can be calculated from formula given above.

Antenna– Beam& Polarization

This chapter deals with the parameters of radiated beam of the antenna. These parameters help us to know about the beam specifications.

Beam Area

According to the standard definition, "Beam area is the solid angle through which all the power radiated by the antenna would stream if $P(\theta, \phi)$ maintained its maximum value over Ω_A and was zero elsewhere."

The radiated beam of the antenna comes out from an angle at the antenna, known as solid angle, where the power radiation intensity is maximum. This **solid beam angle** is termed as the **beam area**. It is represented by Ω_A .

The radiation intensity $P(\theta, \phi)$ should be maintained constant and maximum throughout the solid beam angle Ω_A , its value being zero elsewhere.

$$\text{Power radiated} = P(\theta, \phi)\Omega_A \text{ watts}$$

Beam angle is a set of angles between the half power points of the main lobe.

Mathematical Expression

The mathematical expression for beam area is

$$\Omega_A = \int_0^{2\pi} \int_0^{\pi} P_{\pi}(\theta, \phi) d\Omega \text{ watts}$$

$$d\Omega = \sin\theta d\theta d\phi \text{ watts}$$

where

- Ω_A is the solid beam angle.
- θ is the function of angular position.
- ϕ is the function of radial distance.

Units

The unit of beam area is **watts**.

Beam Efficiency

According to the standard definition, "The **beam efficiency** states the ratio of the beam area of the main beam to the total beam area radiated."

The energy when radiated from an antenna, is projected according to the antenna's directivity. The direction in which an antenna radiates more power has maximum efficiency, while some of the energy is lost in side lobes. The maximum energy radiated by the beam, with minimum losses can be termed as **beam efficiency**.

Mathematical Expression

The mathematical expression for beam efficiency is-

$$\eta_B = \frac{\Omega_{MB}}{\Omega_A}$$

Where,

- η_B is the beam efficiency.
- Ω_{MB} is beam area of the main beam.
- Ω_A is total solid beam angle (beam area).

Antenna Polarization

An Antenna can be polarized depending upon our requirement. It can be linearly polarized or circularly polarized. The type of antenna polarization decides the pattern of the beam and polarization at the reception or transmission.

Linear polarization

When a wave is transmitted or received, it may be done in different directions. The **linear polarization** of the antenna helps in maintaining the wave in a particular direction, avoiding all the other directions. Though this linear polarization is used, the electric field vector stays in the same plane. Hence, we use this linear polarization to improve the **directivity** of the antenna.

Circular polarization

When a wave is circularly polarized, the electric field vector appears to be rotated with all its components losing orientation. The mode of rotation may also be different at times. However, by using **circular polarization**, the effect of multi-path gets reduced and hence it is used in satellite communications such as **GPS**.

Horizontal polarization

Horizontal polarization makes the wave weak, as the reflections from the earth surface affect it. They are usually weak at low frequencies below 1GHz. **Horizontal polarization** is used in the transmission of **TV signals** to achieve a better signal to noise ratio.

Vertical polarization

The low frequency vertically polarized waves are advantageous for ground wave transmission. These are not affected by the surface reflections like the horizontally polarized ones. Hence, the **vertical polarization** is used for **mobile communications**.

Each type of polarization has its own advantages and disadvantages. A RF system designer is free to select the type of polarization, according to the system requirements.

Antenna–Beam Width

In this chapter, we shall discuss about another important factor in the radiation pattern of an antenna, known as **beam width**. In the radiation pattern of an antenna, the main lobe is the main beam of the antenna where maximum and constant energy radiated by the antenna flows.

Beam width is the aperture angle from where most of the power is radiated. The two main considerations of this beam width are Half Power Beam Width (**HPBW**) and First Null Beam Width (**FNBW**)

Half-Power Beam Width

According to the standard definition, "The angular separation, in which the magnitude of the radiation pattern decreases by 50% (or -3dB) from the peak of the main beam, is called the **Half Power Beam Width**."

In other words, Beam width is the area where most of the power is radiated, which is the peak power. **Half power beam width** is the angle in which relative power is more than 50% of the peak power, in the effective radiated field of the antenna.

Indication of HPBW

When a line is drawn between radiation pattern's origin and the half power points on the major lobe, on both the sides, the angle between those two vectors is termed as **HPBW**, half power beam width. This can be well understood with the help of the following diagram.

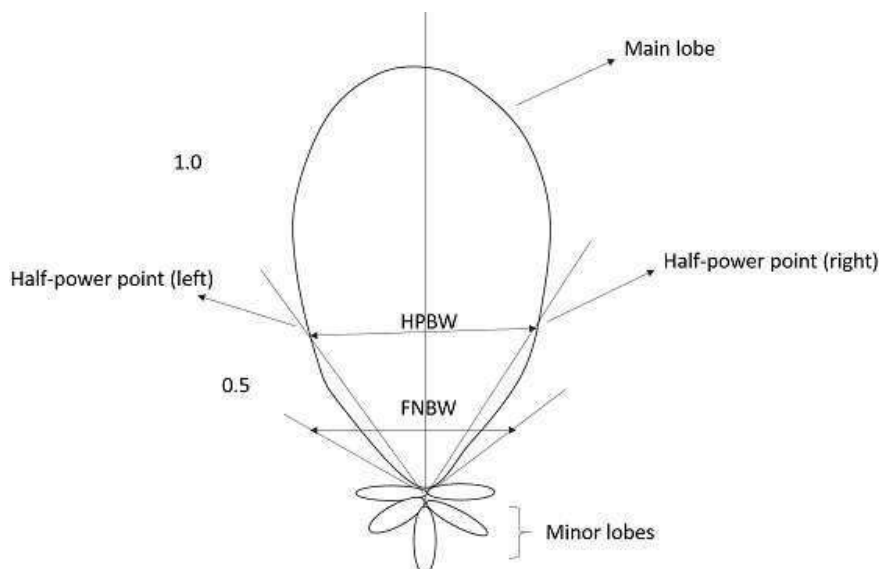

The figure shows half-power points on the major lobe and HPBW.

Mathematical Expression

The mathematical expression for half power beam width is-

$$\text{Half power Beam width} = 70\lambda/D$$

Where

- λ is wavelength ($\lambda = 0.3/\text{frequency}$).
- D is Diameter.

Units

The unit of HPBW is **decibels** or simply **dB**.

First Null Beam Width

According to the standard definition, "The angular span between the first pattern nulls adjacent to the main lobe, is called as the **First Null Beam Width**."

Simply, FNBW is the angular separation, quoted away from the main beam, which is drawn between the null points of radiation pattern, on its major lobe.

Indication of FNBW

Draw tangents on both sides starting from the origin of the radiation pattern, tangential to the main beam. The angle between those two tangents is known as First Null Beam Width (**FNBW**).

This can be better understood with the help of the following diagram.

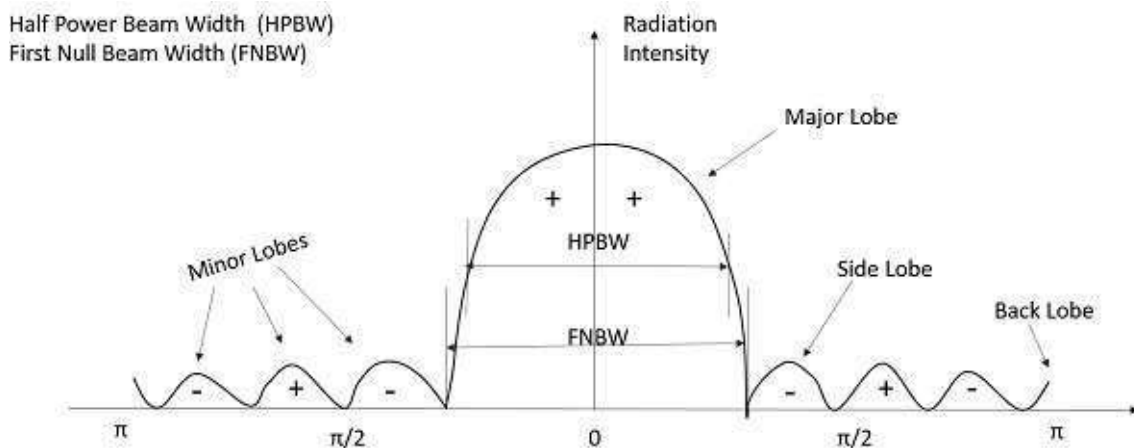

Antenna Parameters illustrated over a typical directional antenna radiation Pattern.

The above image shows the half power beam width and first null beam width, marked in a radiation pattern along with minor and major lobes.

Mathematical Expression

The mathematical expression of First Null Beam Width is

$$FNBW = 2 \text{ HPBW}$$

$$FNBW = 2 (70\lambda/D) = 140 \lambda/D$$

Where

- λ is wavelength ($\lambda = 0.3/\text{frequency}$).
- D is Diameter.

Units

The unit of FNBW is **decibels** or simply **dB**.

Effective Length & Effective Area

Among the antenna parameters, the effective length and effective area are also important. These parameters help us to know about the antenna's performance.

Effective length

Antenna Effective length is used to determine the polarization efficiency of the antenna.

Definition: "The **Effective length** is the ratio of the magnitude of voltage at the open terminals of the receiving antenna to the magnitude of the field strength of the incident wave front, in the same direction of antenna polarization."

When an incident wave arrives at the antenna's input terminals, this wave has some field strength, whose magnitude depends upon the antenna's polarization. This polarization should match with the magnitude of the voltage at receiver terminals.

Mathematical Expression

The mathematical expression for effective length is-

$$l_e = \frac{V_{oc}}{E_i}$$

Where

- l_e is the effective length.
- V_{oc} is open-circuit voltage.
- E_i is the field strength of the incident wave.

Effective area

Definition: "**Effective area** is the area of the receiving antenna, which absorbs most of the power from the incoming wave front, to the total area of the antenna, which is exposed to the wave front."

The whole area of an antenna while receiving, confronts the incoming electromagnetic waves, whereas only some portion of the antenna, receives the signal, known as the **effective area**.

Only some portion of the received wave front is utilized because some portion of the wave gets scattered while some gets dissipated as heat. Hence, without considering the losses, the area, which utilizes the maximum power obtained to the actual area, can be termed as **effective area**.

Effective area is represented by **A_{eff}** .

Antenna—

An antenna can be used as both transmitting antenna and receiving antenna. While using so, we may come across a question whether the properties of the antenna might change as its operating mode is changed. Fortunately, we need not worry about that. The properties of antenna being unchangeable is called as the property of **reciprocity**.

Properties under Reciprocity

The properties of transmitting and receiving antenna that exhibit the reciprocity are-

- Equality of Directional patterns.
- Equality of Directivities.
- Equality of Effective lengths.
- Equality of Antenna impedances.

Let us see how these are implemented.

Equality of Directional patterns

The **radiation pattern** of transmitting antenna₁, which transmits to the receiving antenna₂ is equal to the radiation pattern of antenna₂, if it transmits and antenna₁ receives the signal.

Equality of Directivities

Directivity is same for both transmitting and receiving antennas, if the value of directivity is same for both the cases i.e. the directivities are same whether calculated from transmitting antenna's power or receiving antenna's power.

Equality of Effective lengths

The value of maximum effective aperture is same for both transmitting and receiving antennas. **Equality** in the **lengths** of both transmitting and receiving antennas is maintained according to the value of the wavelength.

Equality in Antenna Impedances

The output impedance of a transmitting antenna and the input impedance of a receiving antenna are equal in an effective communication.

These properties will not change though the same antenna is operated as a transmitter or as a receiver. Hence, the **property of reciprocity** is followed.

Antenna–Poynting

Antennas radiate Electromagnetic energy to transmit or to receive information. Therefore, the terms **Energy** and **Power** are associated with these electromagnetic waves and we have to discuss them. An electromagnetic wave has both electric and magnetic fields.

Consider the wave at any instant, which can be viewed in both the vectors. The following figure shows the representation of electric and magnetic field components in an Electromagnetic wave.

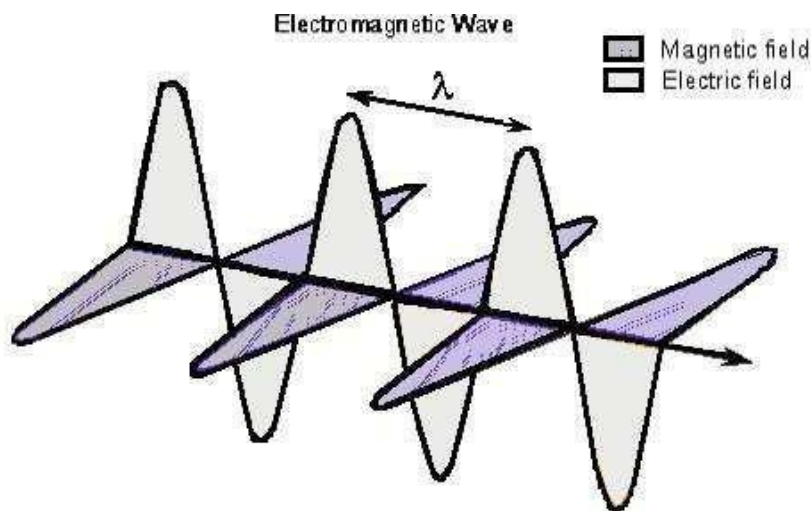

The electric wave is present vertical to the propagation of EM wave, while the magnetic wave is horizontally located. Both the fields are at right angles to each other.

PoyntingVector

Poynting vector describes the energy of the EM Wave per unit time per unit area at any given instant of time. **John Henry Poynting** first derived this vector in 1884 and hence it was named after him.

Definition: "Poynting vector gives the rate of energy transfer per unit area"

or

"The energy that a wave carries per unit time per unit area is given by the Poynting vector."

Poynting vector is represented by \hat{S} .

Units

The SI unit of Poynting vector is **W/m²** .

Mathematical Expression

The quantity that is used to describe the power associated with the electromagnetic waves is the instantaneous **Poynting vector**, which is defined as

$$\hat{S} = \hat{E} \times \hat{H}$$

Where

- \hat{S} is the instantaneous Poynting vector ($\mathbf{W/m^2}$).
- \hat{E} is the instantaneous electric field intensity ($\mathbf{V/m}$).
- \hat{H} is the instantaneous magnetic field intensity ($\mathbf{A/m}$).

The important point to be noted here is that the magnitude of E is greater than H within an EM wave. However, both of them contribute the same amount of energy. \hat{S} is the vector, which has both direction and magnitude. The direction of \hat{S} is same as the velocity of the wave. Its magnitude depends upon the E and H.

Derivation of Poynting Vector

To have a clear idea on Poynting vector, let us go through the derivation of this Poynting vector, in a step-by-step process.

Let us imagine that an EM Wave, passes an area (A) perpendicular to the X-axis along which the wave travels. While passing through A, in infinitesimal time (dt), the wave travels a distance (dx).

$$dx = C dt$$

where

$$C = \text{velocity of light} = 3 \times 10^8 \text{ m/s}$$

$$\text{volume, } dv = A dx = AC dt$$

$$d\mu = \mu dv = (\epsilon_0 E^2)(A C dt)$$

$$= \epsilon_0 A C E^2 dt$$

Therefore, Energy transferred in time (dt) per area (A) is:

$$S = \frac{\text{Energy}}{\text{Time} \times \text{Area}} = \frac{dW}{dt A} = \frac{\epsilon_0 A C E^2 dt}{dt A} = \epsilon_0 C E^2$$

Since

$$\frac{E}{H} = \sqrt{\frac{\mu_0}{\epsilon_0}} \quad \text{then} \quad S = \frac{C B^2}{\mu_0}$$

Since

$$\begin{aligned} C &= \frac{E}{H} \quad \text{then} \quad S = \frac{EB}{\mu_0} \\ &= \hat{S} = \frac{1}{\mu_0} (\hat{E} \hat{H}) \end{aligned}$$

\hat{S} denotes the Poynting vector.

The above equation gives us the energy per unit time, per unit area at any given instant of time, which is called as **Poynting vector**.

Types of Antenna

Antennas have to be classified to understand their physical structure and functionality more clearly. There are many types of antennas depending upon the applications.

The following table gives you the list of various types of antennas along with the examples and applications.

Type of antenna	Examples	Applications
Wire Antennas	Dipole antenna, Monopole antenna, Helix antenna, Loop antenna	Personal applications, buildings, ships, automobiles, space crafts
Aperture Antennas	Waveguide (opening), Horn antenna	Flush-mounted applications, air-craft, space craft
Reflector Antennas	Parabolic reflectors, Corner reflectors	Microwave communication, satellite tracking, radio astronomy
Lens Antennas	Convex-plane, Concave-plane, Convex-convex, Concave-concave lenses	Used for very high-frequency applications
Micro strip Antennas	Circular-shaped, Rectangular-shaped metallic patch above the ground plane	Air-craft, space-craft, satellites, missiles, cars, mobile phones etc.
Array Antennas	Yagi-Uda antenna, Micro strip patch array, Aperture array, Slotted wave guide array	Used for very high gain applications, mostly when needs to control the radiation pattern

Let us discuss the above-mentioned types of antennas in detail, in the coming chapters.

Wire

Wire antennas are the basic types of antennas. These are well known and widely used antennas. To have a better idea of these wire antennas, first let us have a look at the transmission lines.

Transmission Lines

The wire or the **transmission line** has some power, which travels from one end to the other end. If both the ends of transmission line are connected to circuits, then the information will be transmitted or received using this wire between these two circuits.

If one end of this wire is not connected, then the power in it tries to escape. This leads to wireless communication. If one end of the wire is bent, then the energy tries to escape from the transmission line, more effectively than before. This purposeful escape is known as **Radiation**.

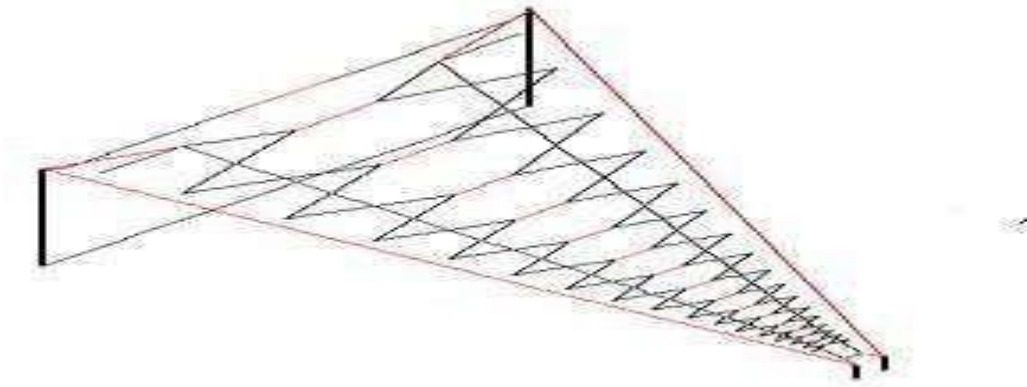

For the radiation to take place effectively, the impedance of the open end of the transmission line should match with the impedance of the free-space. Consider a transmission line of a quarter-wave length size. The far end of it is kept open and bent to provide high impedance. This acts as a **half-wave dipole antenna**. Already, it has low impedance at one end of the transmission line. The open end, which has high impedance, matches with the impedance of free space to provide better radiation.

Dipole

The radiation of energy when done through such a bent wire, the end of such transmission line is termed as **dipole** or dipole antenna.

The reactance of the input impedance is a function of the radius and length of the dipole. The smaller the radius, the larger the amplitude of the reactance. It is proportional to the wavelength. Hence, the length and radius of the dipole should also be taken into consideration. Normally, its impedance is around 72Ω .

This is better understood with the help of the following figure.

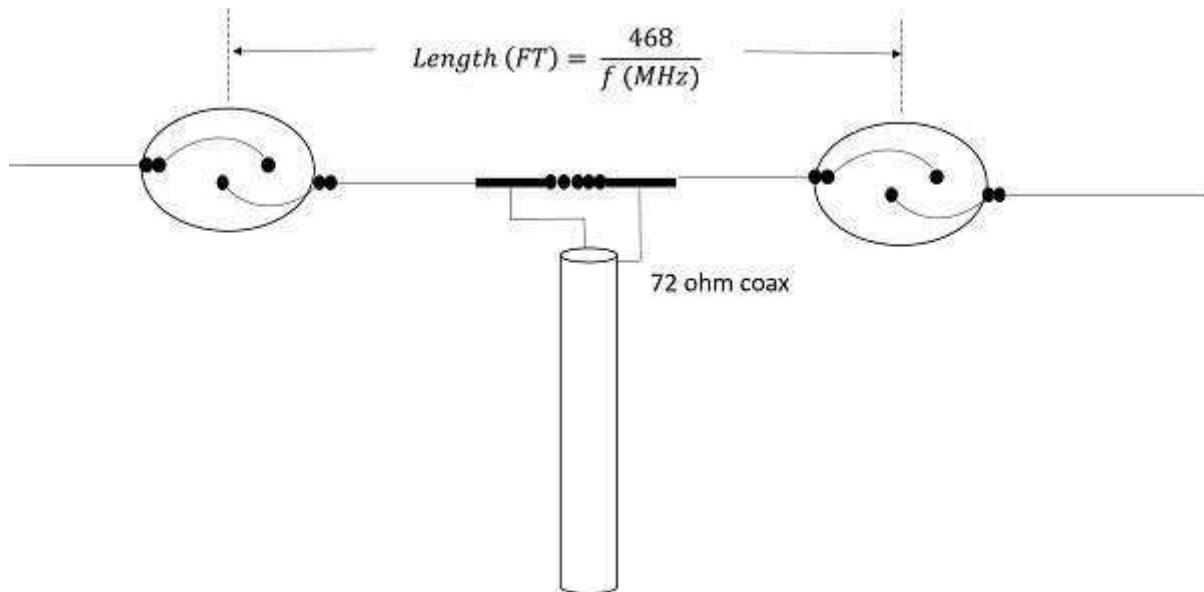

A dipole is a half-wave antenna fed at the center.
Here, the impedance at the center is near 72 ohms.

The figure shows the circuit diagram of a normal dipole connected to a transmission line. The current for a dipole is maximum at the center and minimum at its ends. The voltage is minimum at its center and maximum at its ends.

The types of wire antennas include Half-wave dipole, Half-wave folded dipole, Full-wave dipole, Short dipole, and Infinitesimal dipole. All of these antennas will be discussed in further chapters.

Half-wave Dipole Antenna

The dipole antenna is cut and bent for effective radiation. The length of the total wire, which is being used as a dipole, equals half of the wavelength (i.e., $l = \lambda/2$). Such an antenna is called as **half-wave dipole antenna**. This is the most widely used antenna because of its advantages. It is also known as **Hertz antenna**.

Frequency range

The range of frequency in which half-wave dipole operates is around 3KHz to 300GHz. This is mostly used in radio receivers.

Construction & Working of Half-wave Dipole

It is a normal dipole antenna, where the frequency of its operation is **half of its wavelength**. Hence, it is called as half-wave dipole antenna.

The edge of the dipole has maximum voltage. This voltage is alternating (**AC**) in nature. At the positive peak of the voltage, the electrons tend to move in one direction and at the negative peak, the electrons move in the other direction. This can be explained by the figures given below.

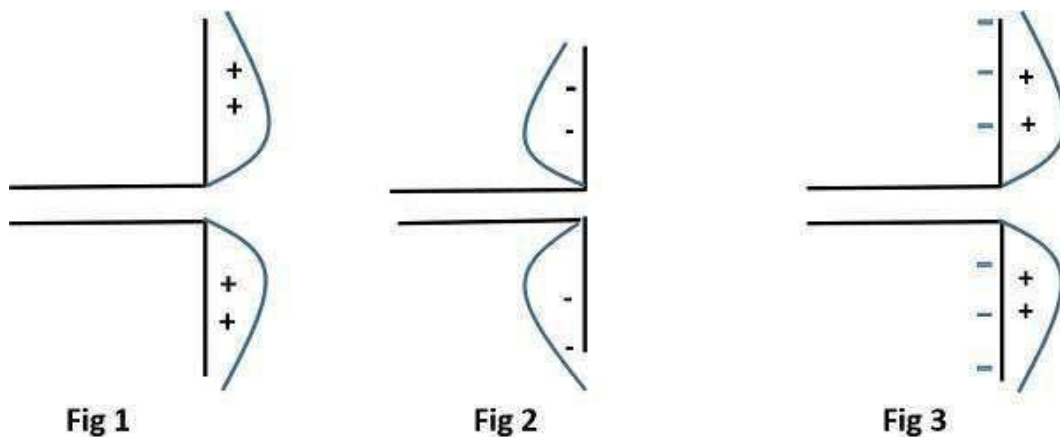

The figures given above show the working of a half-wave dipole.

- Fig 1 shows the dipole when the charges induced are in positive half cycle. Now the electrons tend to move towards the charge.
- Fig 2 shows the dipole with negative charges induced. The electrons here tend to move away from the dipole.
- Fig 3 shows the dipole with next positive half cycle. Hence, the electrons again move towards the charge.

The cumulative effect of this produces a varying field effect which gets radiated in the same pattern produced on it. Hence, the output would be an effective radiation following the cycles of the output voltage pattern. Thus, a half-wave dipole **radiates effectively**.

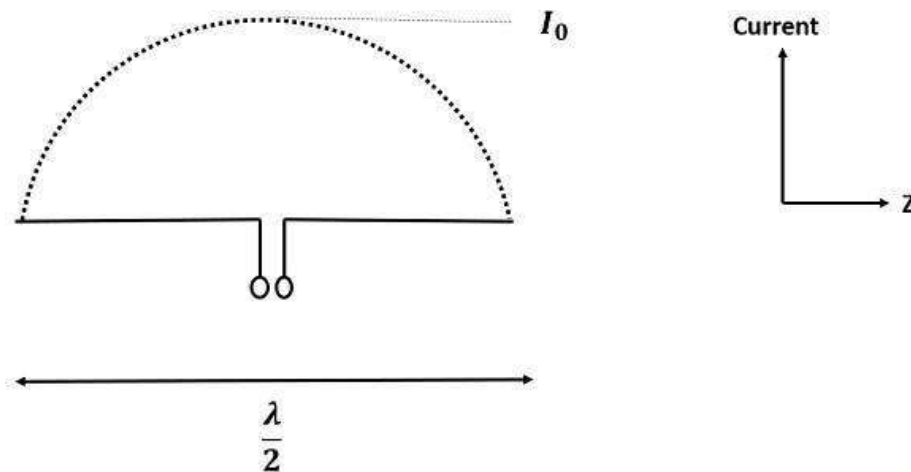

The above figure shows the current distribution in half wave dipole. The directivity of half wave dipole is 2.15dBi, which is reasonably good. Where, 'i' represents the isotropic radiation.

Radiation Pattern

The radiation pattern of this half-wave dipole is **Omni-directional** in the H-plane. It is desirable for many applications such as mobile communications, radio receivers etc.

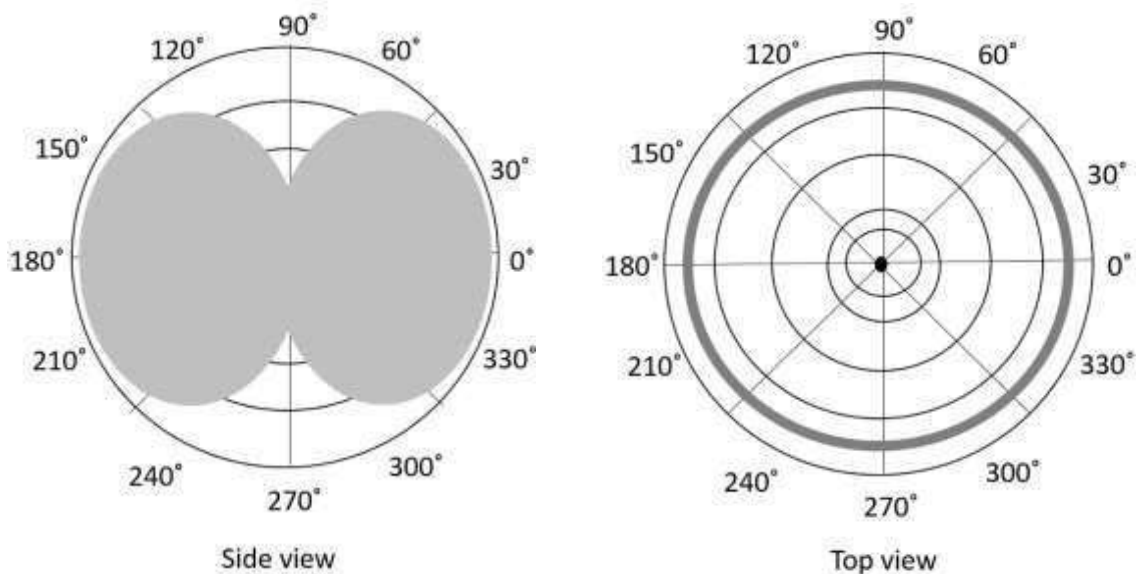

The above figure indicates the radiation pattern of a half wave dipole in both H-plane and V-plane.

The radius of the dipole does not affect its input impedance in this half wave dipole, because the length of this dipole is half wave and it is the first resonant length. An antenna works effectively at its **resonant frequency**, which occurs at its resonant length.

Advantages

The following are the advantages of half-wave dipole antenna-

- Input impedance is not sensitive.
- Matches well with transmission line impedance.
- Has reasonable length.
- Length of the antenna matches with size and directivity.

Disadvantages

The following are the disadvantages of half-wave dipole antenna-

- Not much effective due to single element.
- It can work better only with a combination.

Applications

The following are the applications of half-wave dipole antenna-

- Used in radio receivers.
- Used in television receivers.
- When employed with others, used for wide variety of applications.

Half-wave Folded Dipole Antenna

A folded dipole is an antenna, with two conductors connected on both sides, and folded to form a cylindrical closed shape, to which feed is given at the center. The length of the dipole is half of the wavelength. Hence, it is called as **half wave folded dipole antenna**.

Frequency range

The range of frequency in which half wave folded dipole operates is around **3KHz to 300GHz**. This is mostly used in television receivers.

Construction & Working of Half-wave Folded Dipole

This antenna is commonly used with the array type antennas to increase the feed resistance. The most commonly used one is with Yagi-Uda antenna. The following figure shows a half-wave folded dipole antenna.

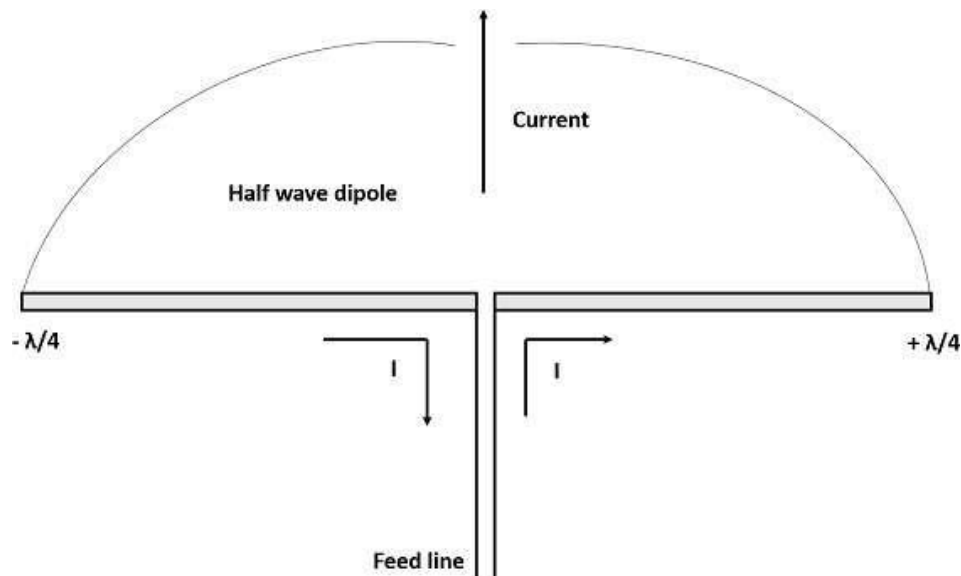

This antenna uses an extra conducting element (a wire or a rod) when compared with previous dipole antenna. This is continued by placing few conducting elements in parallel, with insulation in-between, in array type of antennas.

The following figure explains the working of a half-wave folded dipole antenna, when it is provided with excitation.

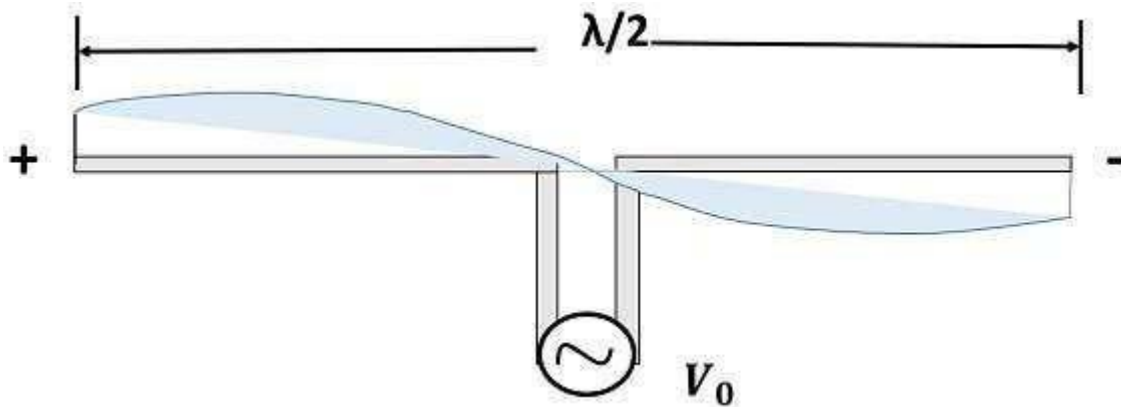

If the diameter of the main conductor and the folded dipole are same, then there will be four folded (two times of squared one) increase in the feed impedance of the antenna. This increase in feed impedance is the main reason for the popular usage of this folded dipole antenna. Due of the twin-lead, the impedance will be around 300Ω .

Radiation Pattern

The radiation pattern of half-wave folded dipoles is the same as that of the half-wave dipole antennas. The following figure shows the radiation pattern of half-wave folded dipole antenna, which is **Omni-directional** pattern.

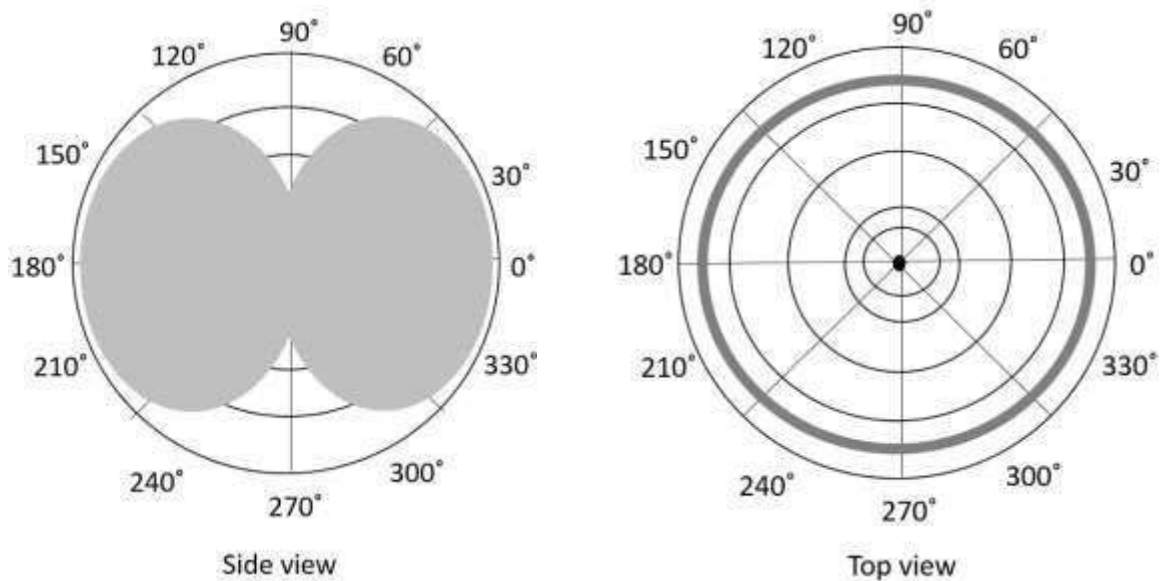

Half-wave folded dipole antennas are used where optimum power transfer is needed and where large impedances are needed.

This folded dipole is the main element in **Yagi-Uda antenna**. The following figure shows a **Yagi-Uda antenna**, which we will study later. The main element used here is this folded dipole, to which the antenna feed is given. This antenna has been used extensively for television reception over the last few decades.

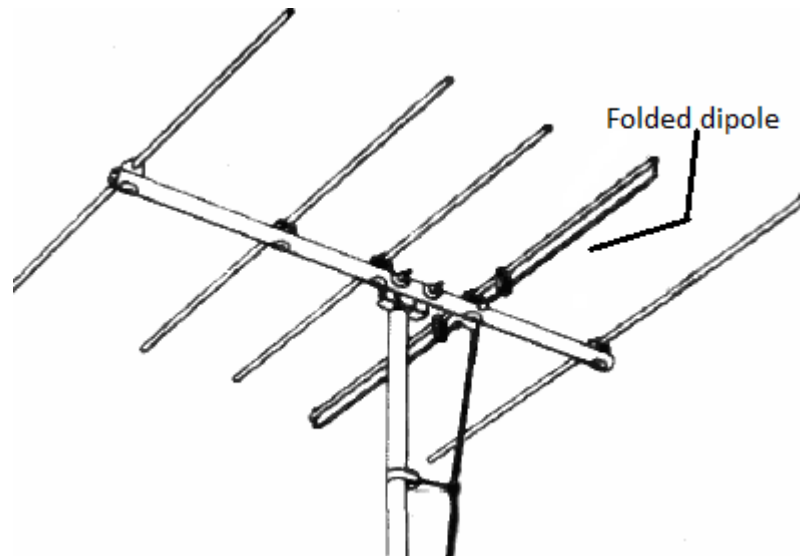

Advantages

The following are the advantages of half-wave folded dipole antenna-

- Reception of balanced signals.
- Receives a particular signal from a band of frequencies without losing the quality.
- A folded dipole maximizes the signal strength.

Disadvantages

The following are the disadvantages of half-wave folded dipole antenna-

- Displacement and adjustment of antenna is a hassle.
- Outdoor management can be difficult when antenna size increases.

Applications

The following are the applications of half-wave folded dipole antenna-

- Mainly used as a feeder element in Yagi antenna, Parabolic antenna, turnstile antenna, log periodic antenna, phased and reflector arrays, etc.
- Generally used in radio receivers.
- Most commonly used in TV receiver antennas.

Full-wave Dipole

If the length of the dipole, i.e. the total wire, equals the full wavelength λ , then it is called as **full wave dipole**. If a full wavelength dipole is used either for transmission or for reception, let us see how the radiation will be.

Construction & Working of Full-wave Dipole

The full-wave dipole with its voltage and current distribution is shown here. Both the positive and negative peaks of the wave induce positive and negative voltages respectively. However, as the induced voltages cancel out each other, there is no question of radiation.

The above figure shows the voltage distribution of full-wave dipole whose length is λ . It is seen that two half-wave dipoles are joined to make a full-wave dipole.

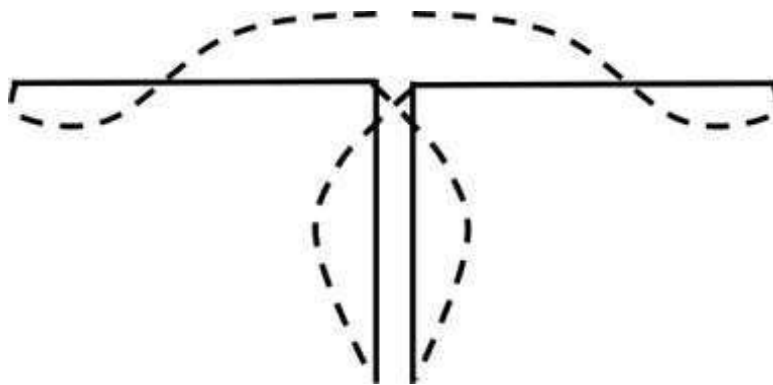

The voltage pattern when induces its positive charges and negative charges at the same time, cancel out each other as shown in the figure. The induced charges make no further attempt of radiation since they are cancelled. The output radiation will be **zero** for a full-wave transmission dipole.

Radiation Pattern

As there is no radiation, there is no question of radiation pattern for this full-wave dipole.

Disadvantages

The following are the disadvantages of full-wave dipole antenna.

- Heat dissipation
- Wastage of power
- No radiation pattern
- No directivity and no gain

Due to these drawbacks, the full-wave dipole is seldom used.

Short Dipole

A **short dipole** is a simple wire antenna. One end of it is open-circuited and the other end is fed with AC source. This dipole got its name because of its length.

Frequency range

The range of frequency in which short dipole operates is around 3KHz to 30MHz. This is mostly used in low frequency receivers.

Construction & Working of Short Dipole

The **Short dipole** is the dipole antenna having the length of its wire shorter than the wavelength. A voltage source is connected at one end while a dipole shape is made, i.e., the lines are terminated at the other end.

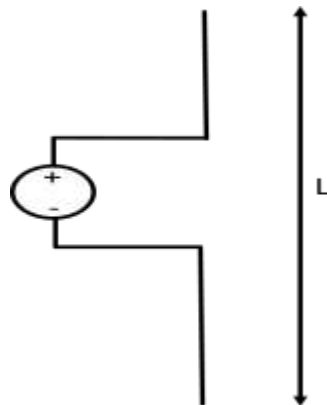

The circuit diagram of a short dipole with length L is shown. The actual size of the antenna does not matter. The wire that leads to the antenna must be less than one-tenth of the wavelength. That is

$$L < \frac{\lambda}{10}$$

Where

- L is the length of the wire of the short dipole.
- λ is the wavelength.

Another type of short dipole is infinitesimal dipole, whose length is far less than its wavelength. Its construction is similar to it, but uses a capacitor plate.

Infinitesimal Dipole

A dipole whose length is far less than wavelength is **infinitesimal dipole**. This antenna is actually impractical. Here, the length of the dipole is less than even fiftieth part of the wavelength.

The length of the dipole, $\Delta l \ll \lambda$. Where, λ is the wavelength.

$$\Delta l = \frac{\lambda}{50}$$

Hence, this is the infinitely small dipole, as the name implies.

As the length of these dipoles is very small, the current flow in the wire will be dI . These wires are generally used with capacitor plates on both sides, where low mutual coupling is needed. Because of the capacitor plates, we can say that uniform distribution of current is present. Hence the current is not zero here.

The capacitor plates can be simply conductors or the wire equivalents. The fields radiated by the radial currents tend to cancel each other in the far field so that the far fields of the capacitor plate antenna can be approximated by the infinitesimal dipole.

Radiation Pattern

The radiation pattern of a short dipole and infinitesimal dipole is similar to a half wave dipole. If the dipole is vertical, the pattern will be circular. The radiation pattern is in the shape of "figure of eight" pattern, when viewed in two-dimensional pattern.

The following figure shows the radiation pattern of a short dipole antenna, which is in **omni-directional pattern**.

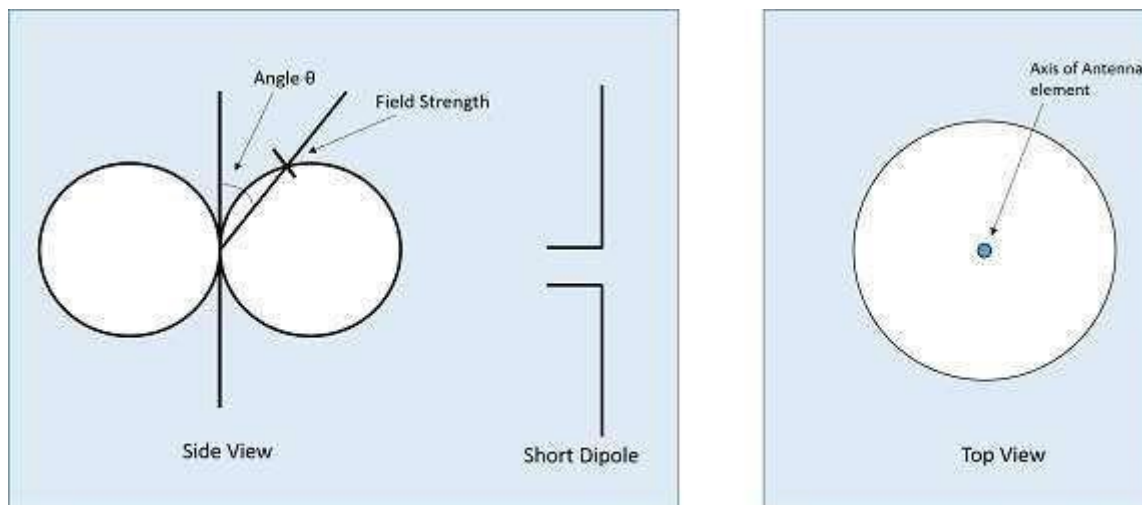

Short dipole antenna radiation pattern

Advantages

The following are the advantages of short dipole antenna-

- Ease of construction, due to small size
- Power dissipation efficiency is higher

Disadvantages

The following are the disadvantages of short dipole antenna-

- High resistive losses
- High power dissipation
- Low Signal-to-noise ratio
- Radiation is low
- Not so efficient

Applications

The following are the applications of short dipole antenna-

- Used in narrow band applications.
- Used as an antenna for tuner circuits.

In this chapter, the popular and most widely used short-wire antennas were discussed. We will discuss the Long-wire antennas in the coming chapters.

Long-wire Antennas

We have gone through different types of short wire antennas. Now, let's look at the long wire antennas. The **long wire antennas** are formed by using a number of dipoles. The length of the wire in these type of antennas is **n** times **$\lambda/2$**

$$L = n \lambda/2$$

Where,

L is the length of the antenna,

n is the number of elements,

λ is the wavelength

As 'n' increases, the directional properties also increase.

Types of Long-wire Antennas

Long wire antennas are divided into two types namely- **Resonant Antennas** and **Non-resonant Antennas**.

Resonant Antennas

Resonant Antennas are those for which a sharp peak in the radiated power is intercepted by the antenna at certain frequency, to form a standing wave. The radiation pattern of the radiated wave is not matched with the load impedance in this type of antenna.

The resonant antennas are periodic in nature. They are also called as bi-directional travelling wave antennas, as the radiated wave moves in two directions, which means both incident and reflected waves occur here. In these antennas, the length of the antenna and frequency are proportional to each other.

Non-resonant Antennas

Non-resonant Antennas are those for which resonant frequency does not occur. The wave moves in forward direction and hence do not form a standing wave. The radiation pattern of the radiated wave matches with the load impedance in the non-resonant antennas.

These non-resonant antennas are non-periodic in nature. They are also called as Uni-directional travelling wave antennas, as the radiated wave moves in forward direction only, which means that only incident wave is present. As the frequency increases, the length of the antenna decreases and vice versa. Hence, the frequency and length are inversely proportional to each other.

These long-wire antennas are the basic elements for the construction of V-shaped antennas or the Rhombic antennas.

Rhombic Antenna

The **Rhombic Antenna** is an equilateral parallelogram shaped antenna. Generally, it has two opposite acute angles. The tilt angle, θ is approximately equal to 90° minus the angle of major lobe. Rhombic antenna works under the principle of travelling wave radiator. It is arranged in the form of a rhombus or diamond shape and suspended horizontally above the surface of the earth.

Frequency Range

The frequency range of operation of a Rhombic antenna is around **3MHz to 300MHz**. This antenna works in **HF** and **VHF** ranges.

Construction of Rhombic Antenna

Rhombic antenna can be regarded as two V-shaped antennas connected end-to-end to form obtuse angles. Due to its simplicity and ease of construction, it has many uses-

- In HF transmission and reception
- Commercial point-to-point communication

The construction of the rhombic antenna is in the form a rhombus, as shown in the figure.

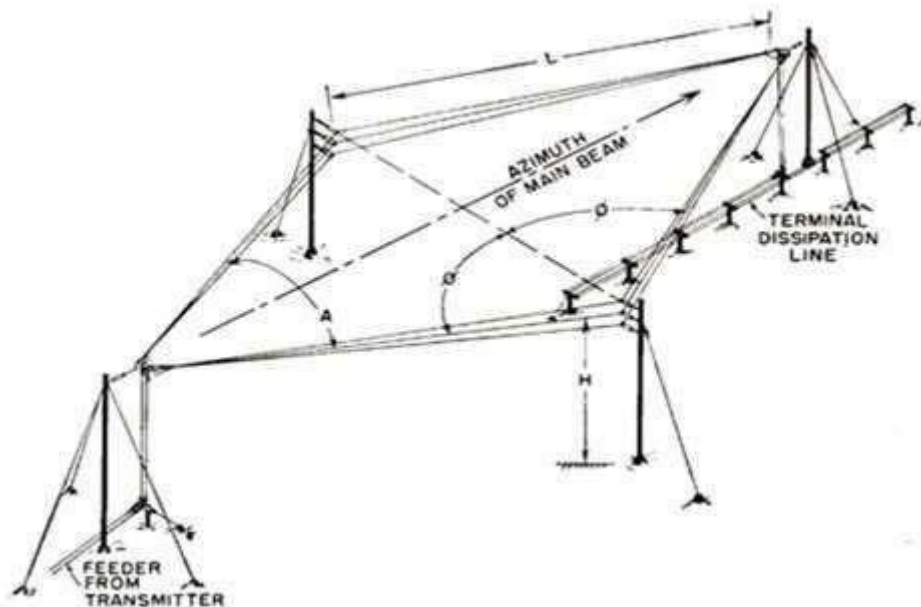

The two sides of rhombus are considered as the conductors of a two-wire transmission line. When this system is properly designed, there is a concentration of radiation along the main axis of radiation. In practice, half of the power is dissipated in the terminating resistance of the antenna. The rest of the power is radiated. The wasted power contributes to the minor lobes.

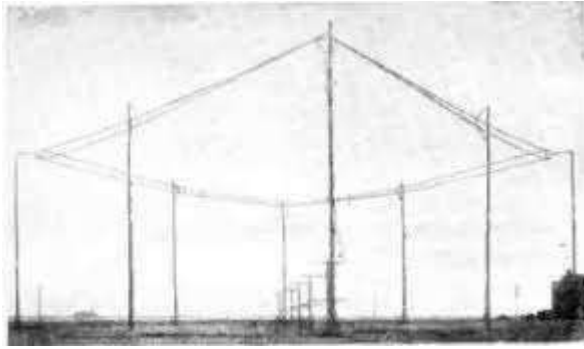

Figure 1

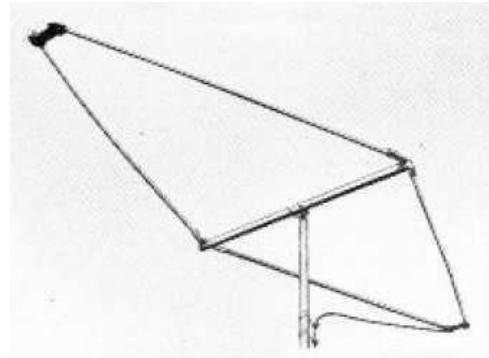

Figure 2

Figure 1 shows the construction of **rhombic antenna** for point-to-point communication in olden days. Figure 2 shows the **rhombic UHF antenna** for TV reception, used these days.

The maximum gain from a rhombic antenna is along the direction of the main axis, which passes through the feed point to terminate in free space. The polarization obtained from a horizontal rhombic antenna is in the plane of rhombus, which is horizontal.

Radiation Pattern

The radiation pattern of the rhombic antenna is shown in the following figure. The resultant pattern is the cumulative effect of the radiation at all four legs of the antenna. This pattern is **uni-directional**, while it can be made bi-directional by removing the terminating resistance.

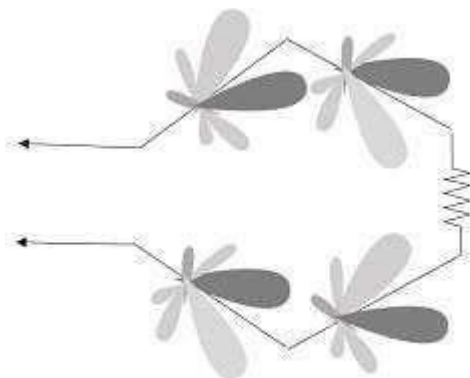

INDIVIDUAL RADIATION PATTERNS

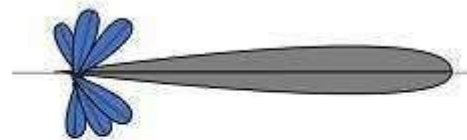

RESULTANT RADIATION PATTERNS

The main disadvantage of rhombic antenna is that the portions of the radiation, which do not combine with the main lobe, result in considerable side lobes having both horizontal and vertical polarization.

Advantages

The following are the advantages of Rhombic antenna-

- Input impedance and radiation pattern are relatively constant
- Multiple rhombic antennas can be connected
- Simple and effective transmission

Disadvantages

The following are the disadvantages of Rhombic antenna-

- Wastage of power in terminating resistor
- Requirement of large space
- Reduced transmission efficiency

Applications

The following are the applications of Rhombic antenna-

- Used in HF communications
- Used in Long distance sky wave propagations
- Used in point-to-point communications

Another method of using long wire is by bending and making the wire into a loop shaped pattern and observing its radiational parameters. This type of antennas are termed as **loop antennas**.

Loop Antennas

An RF current carrying coil is given a single turn into a loop, can be used as an antenna called as **loop antenna**. The currents through this loop antenna will be in phase. The magnetic field will be perpendicular to the whole loop carrying the current.

Frequency Range

The frequency range of operation of loop antenna is around **300MHz to 3GHz**. This antenna works in **UHF** range.

Construction & Working of Loop Antennas

A loop antenna is a coil carrying radio frequency current. It may be in any shape such as circular, rectangular, triangular, square or hexagonal according to the designer's convenience.

Loop antennas are of two types.

- Large loop antennas
- Small loop antennas

Large loop antennas

Large loop antennas are also called as **resonant antennas**. They have high radiation efficiency. These antennas have length nearly equal to the intended wavelength.

$$L = \lambda$$

Where,

- **L** is the length of the antenna
- **λ** is the wavelength

The main parameter of this antenna is its perimeter length, which is about a wavelength and should be an enclosed loop. It is not a good idea to meander the loop so as to reduce the size, as that increases capacitive effects and results in low efficiency.

Small loop antennas

Small loop antennas are also called as **magnetic loop antennas**. These are less resonant. These are mostly used as receivers.

These antennas are of the size of one-tenth of the wavelength.

$$L = \frac{\lambda}{10}$$

Where,

- L is the length of the antenna
- λ is the wavelength

The features of small loop antennas are-

- A small loop antenna has low radiation resistance. If multi-turn ferrite core constructions are used, then high radiation resistance can be achieved.
- It has low radiation efficiency due to high losses.
- Its construction is simple with small size and weight.

Due to its high reactance, its impedance is difficult to match with the transmitter. If loop antenna have to act as transmitting antenna, then this impedance mis-match would definitely be a problem. Hence, these loop antennas are better operated as **receiver antennas**.

FrequentlyUsedLoops

Small loop antennas are mainly of two types-

- Circular loop antennas
- Square loop antennas

These two types of loop antennas are mostly widely used. Other types (rectangular, delta, elliptical etc.) are also made according to the designer specifications.



Fig 1: Circular loop antenna



Fig 2: Square loop antenna

The above images show **circular and square loop antennas**. These types of antennas are mostly used as AM receivers because of high Signal-to-noise ratio. They are also easily tunable at the Q-tank circuit in radio receivers.

Polarizationof Loop

The polarization of the loop antenna will be vertically or horizontally polarized depending upon the feed position. The vertical polarization is given at the center of the vertical side

while the horizontal polarization is given at the center of the horizontal side, depending upon the shape of the loop antenna.

The small loop antenna is generally a **linearly polarized** one. When such a small loop antenna is mounted on top of a portable receiver, whose output is connected to a meter, it becomes a great direction finder.

Radiation Pattern

The radiation pattern of these antennas will be same as that of short horizontal dipole antenna.

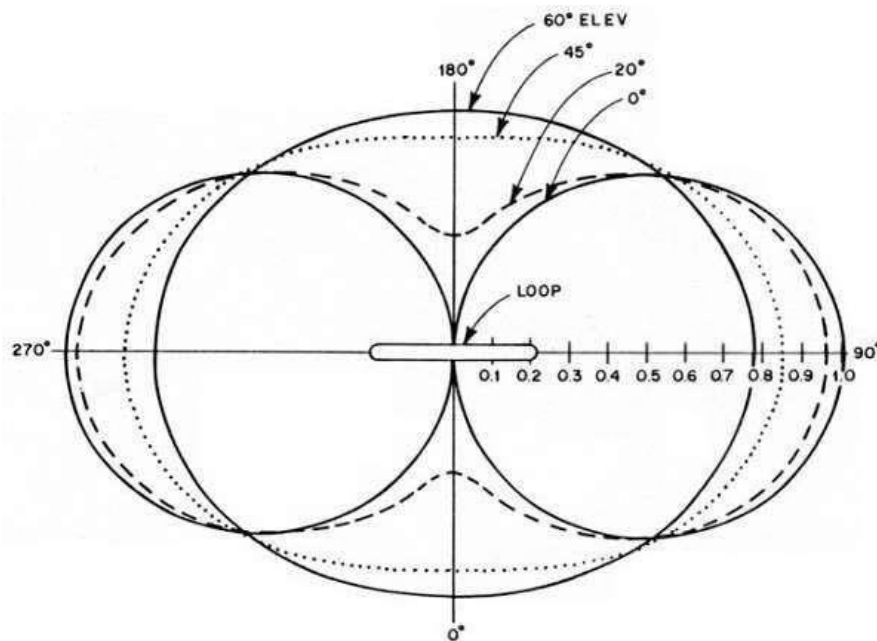

The **radiation pattern** for small, high-efficiency loop antennas is shown in the figure given above. The radiation patterns for different angles of looping are also illustrated clearly in the figure. The tangent line at 0° indicates vertical polarization, whereas the line with 90° indicates horizontal polarization.

Advantages

The following are the advantages of Loop antenna-

- Compact in size
- High directivity

Disadvantages

The following are the disadvantages of Loop antenna-

- Impedance matching may not be always good
- Has very high resonance quality factor

Applications

The following are the applications of Loop antenna-

- Used in RFID devices
- Used in MF, HF and Short wave receivers
- Used in Aircraft receivers for direction finding
- Used in UHF transmitters

Helical Antenna

Helical antenna is an example of wire antenna and itself forms the shape of a helix. This is a broadband VHF and UHF antenna.

Frequency Range

The frequency range of operation of helical antenna is around **30MHz to 3GHz**. This antenna works in **VHF** and **UHF** ranges.

Construction&WorkingofHelicalAntenna

Helical antenna or helix antenna is the antenna in which the conducting wire is wound in helical shape and connected to the ground plane with a feeder line. It is the simplest antenna, which provides **circularly polarized waves**. It is used in extra-terrestrial communications in which satellite relays etc., are involved.



The above image shows a helical antenna system, which is used for satellite communications. These antennas require wider outdoor space.

It consists of a helix of thick copper wire or tubing wound in the shape of a screw thread used as an antenna in conjunction with a flat metal plate called a **ground plate**. One end of the helix is connected to the center conductor of the cable and the outer conductor is connected to the ground plate.

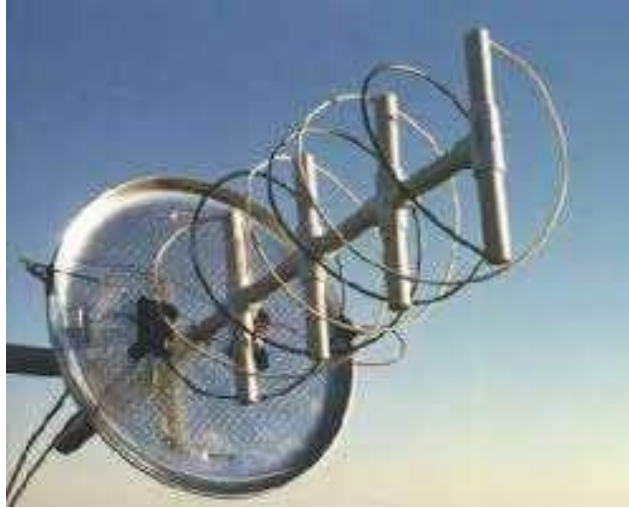

The image of a helix antenna detailing the antenna parts is shown above.

The radiation of helical antenna depends on the diameter of helix, the turn spacing and the pitch angle.

Pitch angle is the angle between a line tangent to the helix wire and plane normal to the helix axis.

$$\alpha = \tan^{-1} \left(\frac{S}{\pi D} \right)$$

where,

- **D** is the **diameter** of helix.
- **S** is the **turn spacing** (centre to centre).
- **α** is the **pitch angle** .

Modes of Operation

The predominant modes of operation of a helical antenna are-

- **Normal** or perpendicular mode of radiation.
- **Axial** or end-fire or beam mode of radiation.

Let us discuss them in detail.

Normal mode

In **normal mode** of radiation, the radiation field is normal to the helix axis. The radiated waves are circularly polarized. This mode of radiation is obtained if the dimensions of helix are small compared to the wavelength. The radiation pattern of this helical antenna is a combination of short dipole and loop antenna.

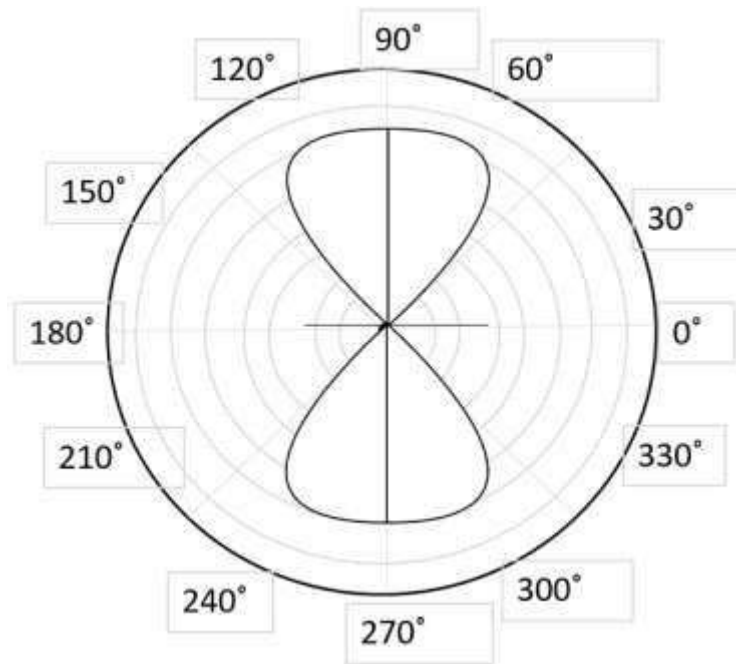

The above figure shows the radiation pattern for normal mode of radiation in helical antenna.

It depends upon the values of diameter of helix, **D** and its turn spacing, **S**. Drawbacks of this mode of operation are low radiation efficiency and narrow bandwidth. Hence, it is hardly used.

Axial mode

In **axial mode** of radiation, the radiation is in the end-fire direction along the helical axis and the waves are circularly or nearly circularly polarized. This mode of operation is obtained by raising the circumference to the order of one wavelength (λ) and spacing of approximately $\lambda/4$. The radiation pattern is broad and directional along the axial beam producing minor lobes at oblique angles.

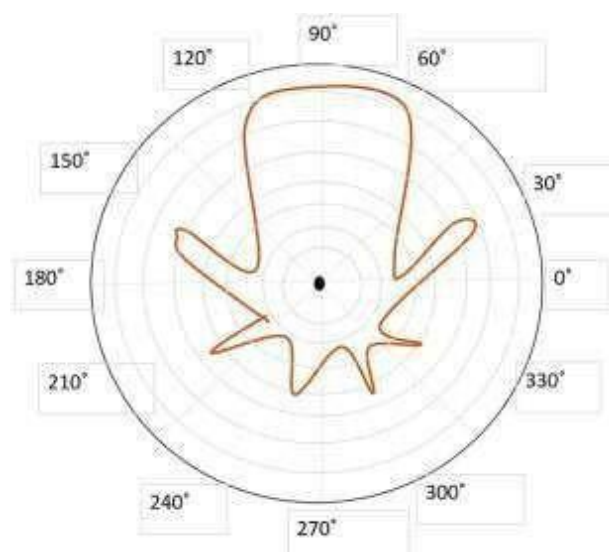

The figure shows the radiation pattern for axial mode of radiation in helical antenna.

If this antenna is designed for right-handed circularly polarized waves, then it will not receive left-handed circularly polarized waves and vice versa. This mode of operation is generated with great ease and is **more practically used**.

Advantages

The following are the advantages of Helical antenna-

- Simple design
- Highest directivity
- Wider bandwidth
- Can achieve circular polarization
- Can be used at HF & VHF bands also

Disadvantages

The following are the disadvantages of Helical antenna-

- Antenna is larger and requires more space
- Efficiency decreases with number of turns

Applications

The following are the applications of Helical antenna-

- A single helical antenna or its array is used to transmit and receive VHF signals
- Frequently used for satellite and space probe communications
- Used for telemetry links with ballistic missiles and satellites at Earth stations
- Used to establish communications between the moon and the Earth
- Applications in radio astronomy

Aperture Antennas

An Antenna with an aperture at the end can be termed as an **Aperture antenna**. Waveguide is an example of aperture antenna. The edge of a transmission line when terminated with an opening, radiates energy. This opening which is an aperture, makes it an **Aperture** antenna.

The main types of aperture antennas are-

- Wave guide antenna
- Horn antenna
- Slot antenna

Let us now have a look at these types of aperture antennas.

Waveguide Antenna

A **Waveguide** is capable of radiating energy when excited at one end and opened at the other end. The radiation in wave guide is greater than a two-wire transmission line.

Frequency Range

The operational frequency range of a wave guide is around **300MHz** to **300GHz**. This antenna works in **UHF** and **EHF** frequency ranges. The following image shows a waveguide.

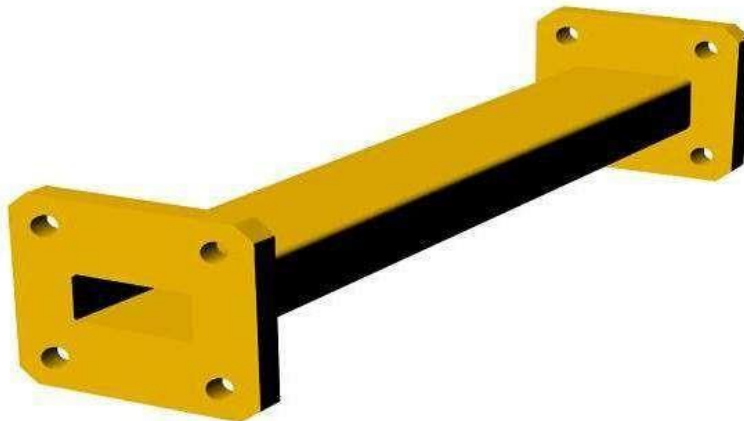

This waveguide with terminated end, acts as an antenna. But only a small portion of the energy is radiated while a large portion of it gets reflected back in the open circuit. It means **VSWR** (voltage standing wave ratio, discussed in basic parameters chapter) value increases. The diffraction around the waveguide provides poor radiation and non-directive radiation pattern.

Radiation Pattern

The radiation of waveguide antenna is poor and the pattern is non-directive, which means **omni-directional**. An omni-directional pattern is the one which has no certain directivity but radiates in all directions, hence it is called as **non-directive radiation pattern**.

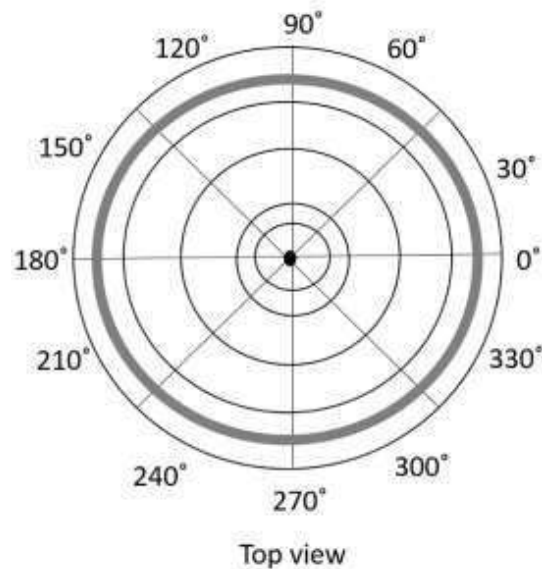

The above figure shows a top section view of an omni-directional pattern, which is also called as **non-directional pattern**. The two-dimensional view is a figure-of-eight pattern, as we already know.

Advantages

The following are the advantages of Aperture antenna-

- Radiation is greater than two-wire transmission line
- Radiation is Omni-directional

Disadvantages

The following are the disadvantages of Aperture antenna-

- VSWR increases
- Poor radiation

Applications

The following are the applications of Aperture antenna-

- Micro wave applications
- Surface search radar applications

The waveguide antenna has to be further modified to achieve better performance, which results in the formation of **Horn antenna**.

Horn Antenna

To improve the radiation efficiency and directivity of the beam, the wave guide should be provided with an extended aperture to make the abrupt discontinuity of the wave into a gradual transformation. So that all the energy in the forward direction gets radiated. This can be termed as **Flaring**. Now, this can be done using a horn antenna.

Frequency Range

The operational frequency range of a horn antenna is around **300MHz** to **30GHz**. This antenna works in **UHF** and **SHF** frequency ranges.

Construction & Working of Horn Antenna

The energy of the beam when slowly transform into radiation, the losses are reduced and the focussing of the beam improves. A **Horn antenna** may be considered as a **flared out wave guide**, by which the directivity is improved and the diffraction is reduced.



The above image shows the model of a horn antenna. The flaring of the horn is clearly shown. There are several horn configurations out of which, three configurations are most commonly used.

Sectoral horn

This type of horn antenna, flares out in only one direction. Flaring in the direction of Electric vector produces the **sectorial E-plane horn**. Similarly, flaring in the direction of Magnetic vector, produces the **sectorial H-plane horn**.

Pyramidal horn

This type of horn antenna has flaring on both sides. If flaring is done on both the E & H walls of a rectangular waveguide, then **pyramidal horn antenna** is produced. This antenna has the shape of a truncated pyramid.

Conical horn

When the walls of a circular wave guide are flared, it is known as a **conical horn**. This is a logical termination of a circular wave guide.

DIFFERENT TYPES OF HORN ANTENNA

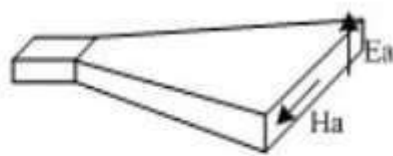

H-plane sectoral horn

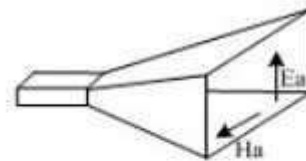

Pyramidal horn

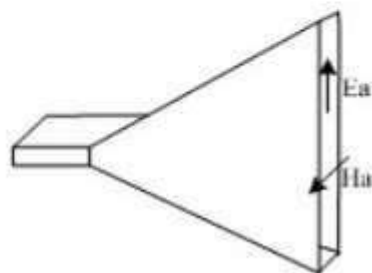

E-plane sectoral horn

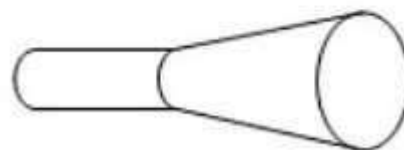

Conical Horn Antenna

The above figures show the types of horn configurations, which were discussed earlier.

Flaring helps to match the antenna impedance with the free space impedance for better radiation. It avoids standing wave ratio and provides greater directivity and narrower beam width. The flared wave guide can be technically termed as **Electromagnetic Horn Radiator**.

Flare angle, Φ of the horn antenna is an important factor to be considered. If this is too small, then the resulting wave will be spherical instead of plane and the radiated beam

will not be directive. Hence, the flare angle should have an optimum value and is closely related to its length.

Combinations

Horn antennas, may also be combined with parabolic reflector antennas to form special type of horn antennas. These are-

- Cass-horn antenna
- Hog-horn or triply folded horn reflector

In **Cass-horn antenna**, radio waves are collected by the large bottom surface, which is parabolically curved and reflected upward at 45° angle. After hitting top surface, they are reflected to the focal point. The gain and beam width of these are just like parabolic reflectors.

In **hog-horn** antenna, a parabolic cylinder is joined to pyramidal horn, where the beam reaches apex of the horn. It forms a low-noise microwave antenna. The main advantage of hog-horn antenna is that its receiving point does not move, though the antenna is rotated about its axis.

RadiationPattern

The radiation pattern of a horn antenna is a Spherical Wave front. The following figure shows the **radiation pattern** of horn antenna. The wave radiates from the aperture, minimizing the diffraction of waves. The flaring keeps the beam focussed. The radiated beam has high directivity.

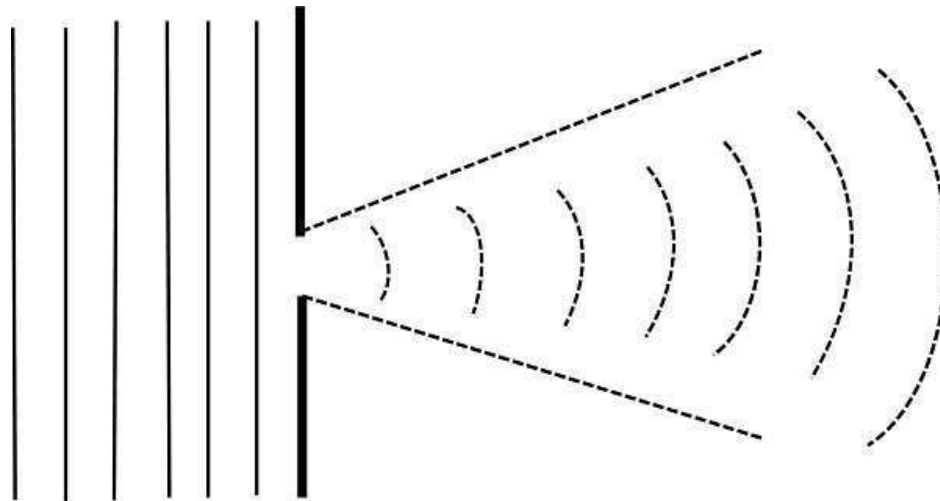

Advantages

The following are the advantages of Horn antenna-

- Small minor lobes are formed
- Impedance matching is good
- Greater directivity
- Narrower beam width

- Standing waves are avoided

Disadvantages

The following are the disadvantages of Horn antenna-

- Designing of flare angle, decides the directivity
- Flare angle and length of the flare should not be very small

Applications

The following are the applications of Horn antenna-

- Used for astronomical studies
- Used in microwave applications

Parabolic Reflector Antennas

Parabolic Reflectors are Microwave antennas. For better understanding of these antennas, the concept of parabolic reflector has to be discussed.

Frequency Range

The frequency range used for the application of Parabolic reflector antennas is **above 1MHz**. These antennas are widely used for radio and wireless applications.

Principle of Operation

The standard definition of a parabola is - Locus of a point, which moves in such a way that its distance from the fixed point (called **focus**) plus its distance from a straight line (called **directrix**) is constant.

The following figure shows the geometry of parabolic reflector. The point **F** is the focus (feed is given) and **V** is the vertex. The line joining F and V is the axis of symmetry. PQ are the reflected rays where **L** represents the line directrix on which the reflected points lie (to say that they are being collinear). Hence, as per the above definition, the distance between F and L lie constant with respect to the waves being focussed.

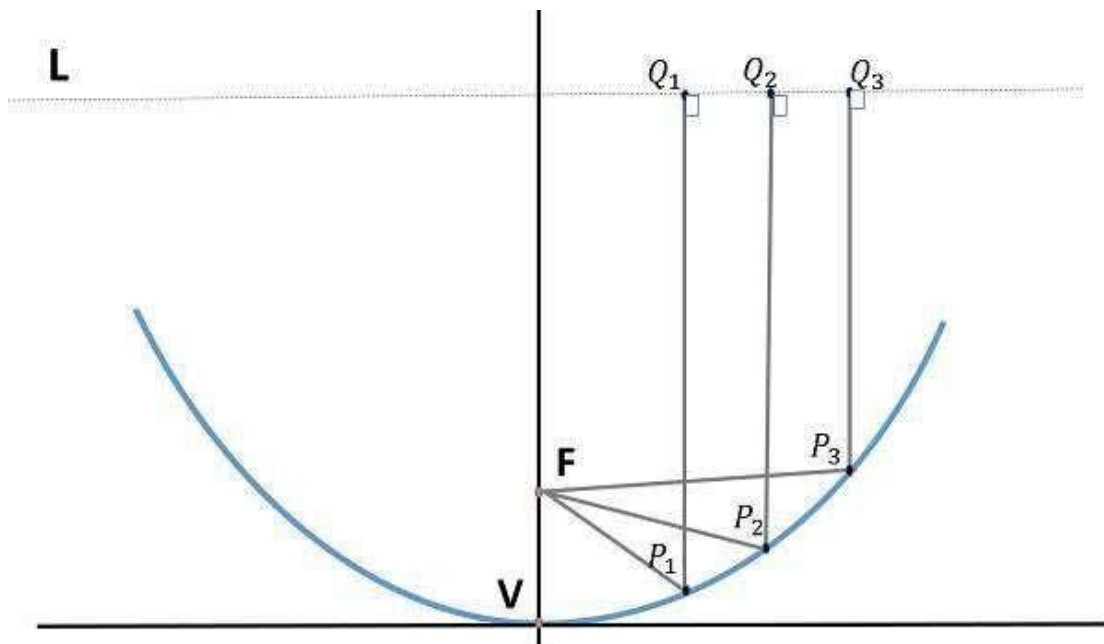

The reflected wave forms a collimated wave front, out of the parabolic shape. The ratio of focal length to aperture size (ie., f/D) known as "**f over D ratio**" is an important parameter of parabolic reflector. Its value varies from **0.25 to 0.50**.

The law of reflection states that the angle of incidence and the angle of reflection are equal. This law when used along with a parabola, helps the beam focus. The shape of the parabola when used for the purpose of reflection of waves, exhibits some properties of the parabola, which are helpful for building an antenna, using the waves reflected.

Properties of Parabola

- All the waves originating from focus, reflects back to the parabolic axis. Hence, all the waves reaching the aperture are in phase.
- As the waves are in phase, the beam of radiation along the parabolic axis will be strong and concentrated.

Following these points, the parabolic reflectors help in producing high directivity with narrower beam width.

Construction & Working of a Parabolic Reflector

If a Parabolic Reflector antenna is used for transmitting a signal, the signal from the feed, comes out of a dipole or a horn antenna, to focus the wave on to the parabola. It means that, the waves come out of the focal point and strike the Paraboloidal reflector. This wave now gets reflected as **collimated wave front**, as discussed previously, to get transmitted.

The same antenna is used as a receiver. When the electromagnetic wave hits the shape of the parabola, the wave gets reflected onto the feed point. The dipole or the horn antenna, which acts as the receiver antenna at its feed, receives this signal, to convert it into electric signal and forwards it to the receiver circuitry.

The following image shows a Parabolic Reflector Antenna.



The gain of the paraboloid is a function of aperture ratio (D/λ). The Effective Radiated Power (**ERP**) of an antenna is the multiplication of the input power fed to the antenna and its power gain.

Usually a wave guide horn antenna is used as a feed radiator for the paraboloid reflector antenna. Along with this technique, we have another type of feed given to the paraboloid reflector antenna, called as Cassegrain feed.

Cassegrain Feed

Casse grain is another type of feed given to the reflector antenna. In this type, the feed is located at the vertex of the paraboloid, unlike in the parabolic reflector. A convex shaped reflector, which acts as a hyperboloid is placed opposite to the feed of the antenna. It is also known as **secondary hyperboloid reflector** or **sub-reflector**. It is placed such that its one of the foci coincides with the focus of the paraboloid. Thus, the wave gets reflected twice.

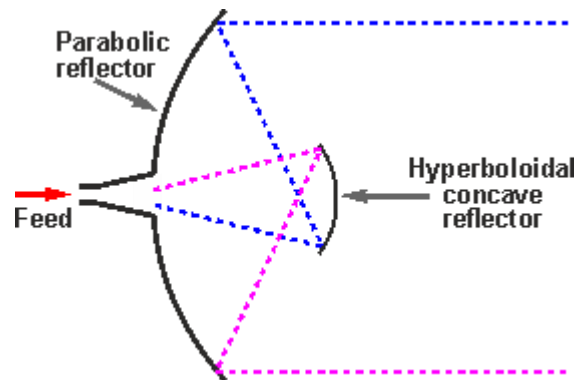

The above figure shows the working model of cassegrain feed.

Working of a Cassegrain Antenna

When the antenna acts as a transmitting antenna, the energy from the feed radiates through a horn antenna onto the hyperboloid concave reflector, which again reflects back on to the parabolic reflector. The signal gets reflected into the space from there. Hence, wastage of power is controlled and the directivity gets improved.

When the same antenna is used for reception, the electromagnetic waves strike the reflector, get reflected on to the concave hyperboloid and from there, it reaches to the feed. A wave guide horn antenna presents there to receive this signal and sends to the receiver circuitry for amplification.

Take a look at the following image. It shows a paraboloid reflector with cassegrain feed.



Advantages

The following are the advantages of Parabolic reflector antenna-

- Reduction of minor lobes
- Wastage of power is reduced
- Equivalent focal length is achieved
- Feed can be placed in any location, according to our convenience
- Adjustment of beam (narrowing or widening) is done by adjusting the reflecting surfaces

Disadvantage

The following is the disadvantage of a Parabolic reflector antenna-

- Some of the power that gets reflected from the parabolic reflector is obstructed. This becomes a problem with small dimension paraboloid.

Applications

The following are the applications of Parabolic reflector antenna-

- The cassegrain feed parabolic reflector is mainly used in satellite communications.
- Also used in wireless telecommunication systems.

Let us look at the other type of feed called as Gregorian feed for the parabolic reflectors.

Antenna Arrays

An antenna, when individually can radiate an amount of energy, in a particular direction, resulting in better transmission, how it would be if few more elements are added it, to produce more efficient output. It is exactly this idea, which led to the invention of **Antenna arrays**.

An antenna array can be better understood by observing the following images. Observe how the antenna arrays are connected.



An **antenna array** is a radiating system, which consists of individual radiators and elements. Each of this radiator, while functioning has its own induction field. The elements are placed so closely that each one lies in the neighbouring one's induction field. Therefore, the radiation pattern produced by them, would be the vector sum of the individual ones. The following image shows another example of an antenna array.



The spacing between the elements and the length of the elements according to the wavelength are also to be kept in mind while designing these antennas.

The antennas radiate individually and while in array, the radiation of all the elements sum up, to form the radiation beam, which has high gain, high directivity and better performance, with minimum losses.

Advantages

The following are the advantages of using antenna arrays-

- The signal strength increases
- High directivity is obtained
- Minor lobes are reduced much
- High Signal-to-noise ratio is achieved
- High gain is obtained
- Power wastage is reduced
- Better performance is obtained

Disadvantages

The following are the disadvantages of array antennas-

- Resistive losses are increased
- Mounting and maintenance is difficult
- Huge external space is required

Applications

The following are the applications of array antennas-

- Used in satellite communications
- Used in wireless communications
- Used in military radar communications
- Used in the astronomical study

Types of Arrays

The basic types of arrays are-

- Collinear array
- Broad side array
- End fire array
- Parasitic array
- Yagi-Uda array
- Log-periodic array
- Turnstile array
- Super-turnstile array

We will discuss these arrays in the coming chapters.

Collineararray

A **Collinear array** consists of two or more half-wave dipoles, which are placed end to end. These antennas are placed on a common line or axis, being parallel or collinear.

The maximum radiation in these arrays is broad side and perpendicular to the line of array. These arrays are also called as **broad cast** or **Omni-directional arrays**.

Frequency range

The frequency range in which the collinear array antennas operate is around **30 MHz** to **3GHz** which belong to the **VHF** and **UHF** bands.

Construction of Array

These collinear arrays are **uni-directional antennas** having high gain. The main purpose of this array is to increase the power radiated and to provide high directional beam, by avoiding power loss in other directions.

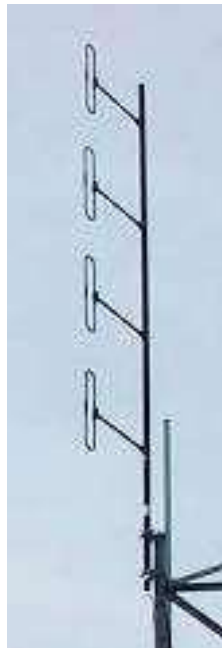

Figure1

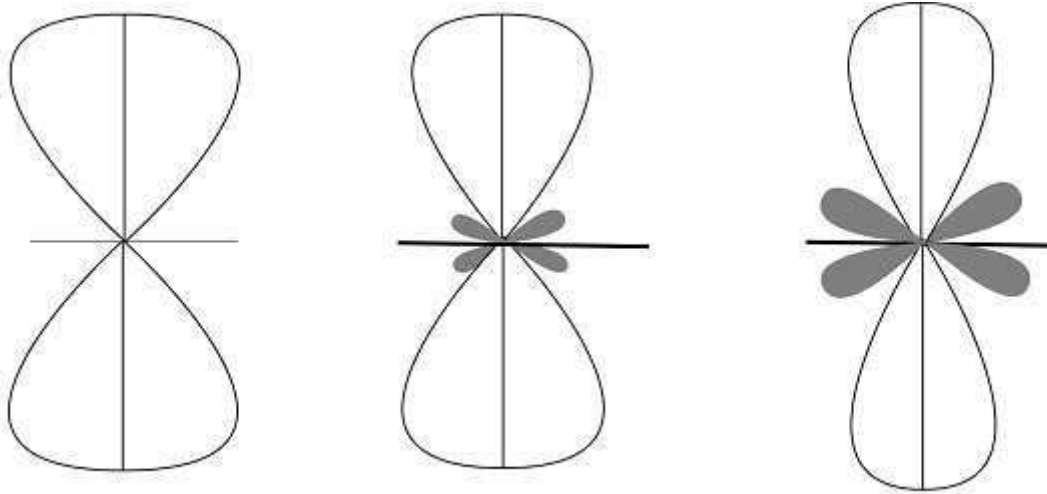

Figure2

The above images show the pictures of collinear arrays. In figure 1, it is seen that collinear array is formed using folded dipoles, while in figure 2, the collinear array is formed by normal dipoles. Both types are half-wave dipoles used commonly.

Radiation Pattern

The radiation pattern of these collinear arrays is similar to that of a single dipole, but the array pattern of increasing number of dipoles, makes the difference.



PATTERN WITH TWO ELEMENTS

PATTERN WITH THREE ELEMENTS

PATTERN WITH FOUR ELEMENTS

The radiation pattern of collinear array when made using two elements, three elements and four elements respectively are shown in the figure given above.

The **broad side array** also has the same pattern, in which the direction of maximum radiation is perpendicular to the line of antenna.

Advantages

The following are the advantages of collinear array antennas-

- Use of array reduces the broad ends and increases the directivity
- Minor lobes are minimised
- Wastage of power is reduced

Disadvantages

The following are the disadvantages of collinear array antennas-

- Displacement of these antennas is a difficult task
- Used only in outdoor areas

Applications

The following are the applications of collinear array antennas-

- Used for VHF and UHF bands
- Used in two-way communications
- Used also for broadcasting purposes

Broad-side Array

The antenna array in its simplest form, having a number of elements of equal size, equally spaced along a straight line or axis, forming collinear points, with all dipoles in the same phase, from the same source together form the **broad side array**.

Frequency range

The frequency range, in which the collinear array antennas operate is around **30 MHz** to **3GHz** which belong to the **VHF** and **UHF** bands.

Construction & Working of Broad-side Array

According to the standard definition, "An arrangement in which the principal direction of radiation is perpendicular to the array axis and also to the plane containing the array element" is termed as the **broad side array**. Hence, the radiation pattern of the antenna is perpendicular to the axis on which the array exists.

The following diagram shows the broad side array, in front view and side view, respectively.

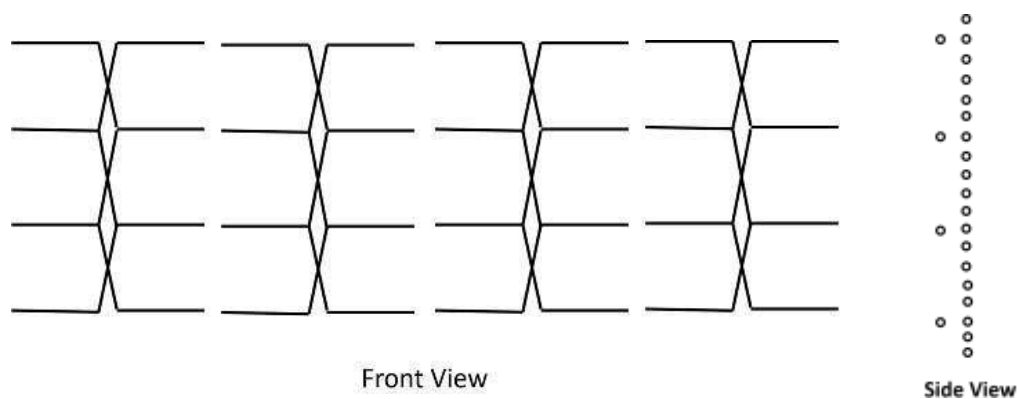

The broad side array is strongly directional at right angles to the plane of the array. However, the radiation in the plane will be very less because of the cancellation in the direction joining the center.

The figure of broad side array with $\lambda/4$ spacing is shown below.

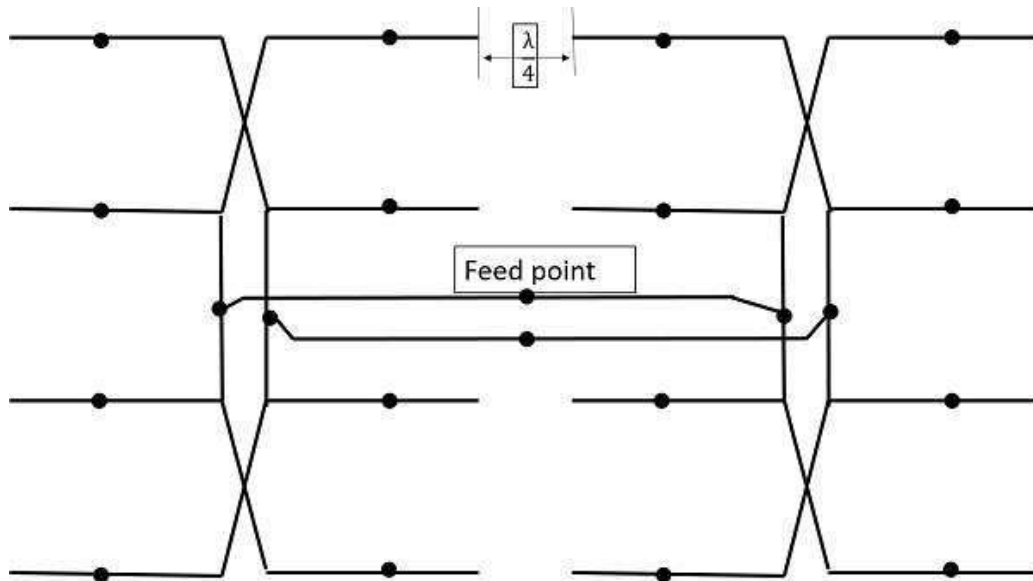

Typical antenna lengths in the broad side array are from 2 to 10 wavelengths. Typical spacings are $\lambda/2$ or λ . The feed points of the dipoles are joined as shown in the figure.

Radiation Pattern

The radiation pattern of this antenna is bi-directional and right angles to the plane. The beam is very narrow with high gain.

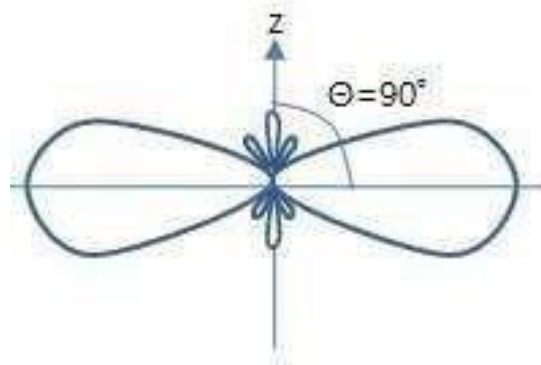

The above figure shows the radiation pattern of the broad side array. The beam is a bit wider and minor lobes are much reduced in this.

End-fire Array

The physical arrangement of **end-fire array** is same as that of the broad side array. The magnitude of currents in each element is same, but there is a phase difference between these currents. This induction of energy differs in each element, which can be understood by the following diagram.

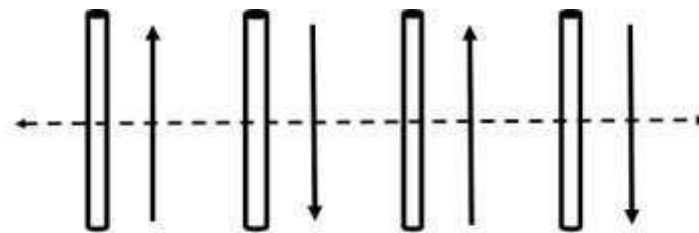

Top View of Array



Side View of Array

The above figure shows the end-fire array in top and side views respectively.

There is no radiation in the right angles to the plane of the array because of cancellation. The first and third elements are fed out of phase and therefore cancel each other's radiation. Similarly, second and fourth are fed out of phase, to get cancelled.

The usual dipole spacing will be $\lambda/4$ or $3\lambda/4$. This arrangement not only helps to avoid the radiation perpendicular to the antenna plane, but also helps the radiated energy get diverted to the direction of radiation of the whole array. Hence, the minor lobes are avoided and the directivity is increased. The beam becomes narrower with the increased elements.

Radiation Pattern

The Radiation pattern of end-fire array is **uni-directional**. A major lobe occurs at one end, where maximum radiation is present, while the minor lobes represent the losses.

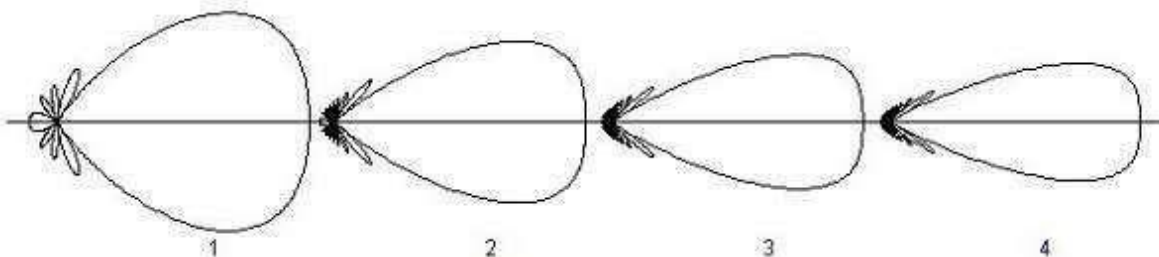

The figure explains the radiation pattern of an end-fire array. Figure 1 is the radiation pattern for a single array, while figures 2, 3, and 4 represent the radiation pattern for multiple arrays.

End-fire Array Vs Broad Side Array

We have studied both the arrays. Let us try to compare the end-fire and broad side arrays, along with their characteristics.

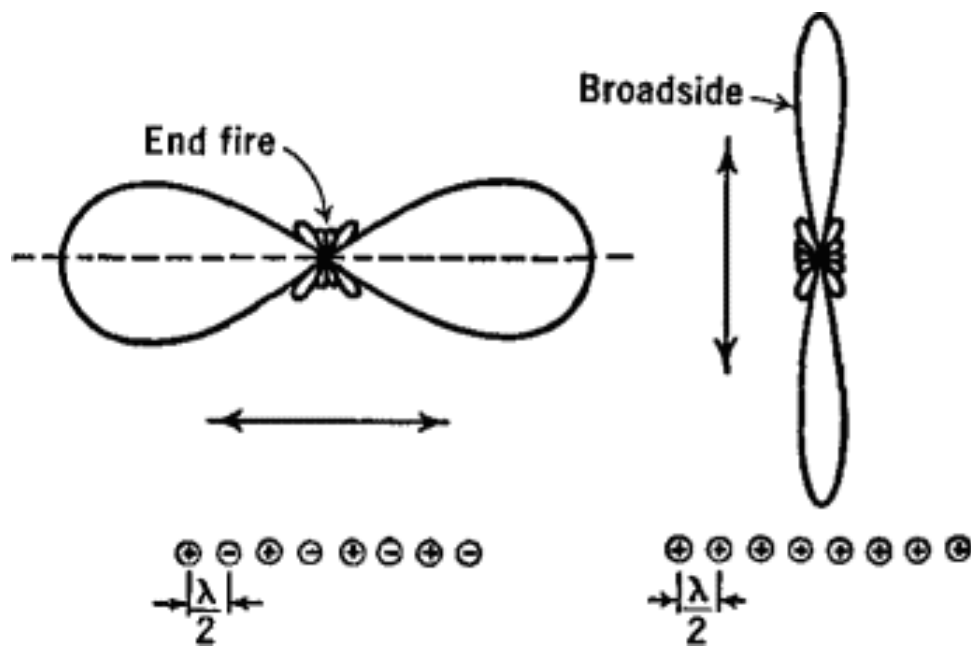

The figure illustrates the radiation pattern of end-fire array and broad side array.

- Both, the end fire array and broad side array, are linear and are resonant, as they consist of resonant elements.
- Due to resonance, both the arrays display narrower beam and high directivity.
- Both of these arrays are used in transmission purposes.
- Neither of them is used for reception, because the necessity of covering a range of frequencies is needed for any kind of reception.

Yagi-Uda Antenna

Yagi-Uda antenna is the most commonly used type of antenna for TV reception over the last few decades. It is the most popular and easy-to-use type of antenna with better performance, which is famous for its high gain and directivity.

Frequency range

The frequency range in which the Yagi-Uda antennas operate is around **30 MHz** to **3GHz** which belong to the **VHF** and **UHF** bands.

Construction of Yagi-Uda Antenna

A Yagi-Uda antenna was seen on top of almost every house during the past decades. The parasitic elements and the dipole together form this Yagi-Uda antenna.



The figure shows a **Yagi-Uda antenna**. It is seen that there are many directors placed to increase the directivity of the antenna. The feeder is the folded dipole. The reflector is the lengthy element, which is at the end of the structure.

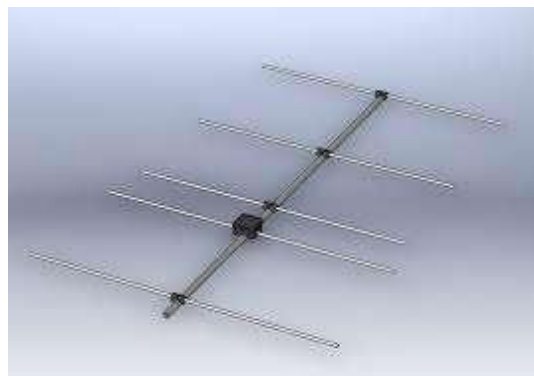

The figure depicts a clear form of the Yagi-Uda antenna. The center rod like structure on which the elements are mounted is called as **boom**. The element to which a thick black head is connected is the **driven element** to which the transmission line is connected internally, through that black stud. The single element present at the back of the driven

element is the **reflector**, which reflects all the energy towards the direction of the radiation pattern. The other elements, before the driven element, are the **directors**, which direct the beam towards the desired angle.

Designing

For this antenna to be designed, the following design specifications should be followed.

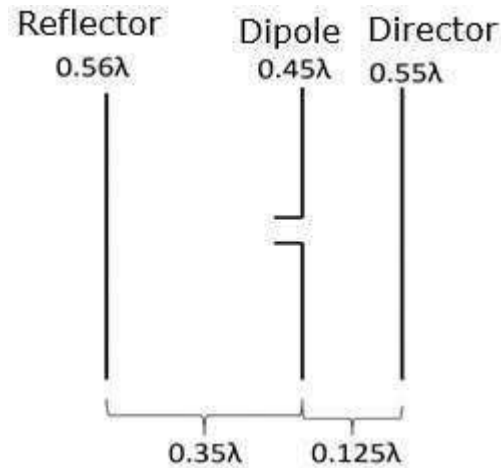

They are as follows–

ELEMENT	SPECIFICATION
Length of the Driven Element	0.458λ to 0.5λ
Length of the Reflector	0.55λ to 0.58λ
Length of the Director 1	0.45λ
Length of the Director 2	0.40λ
Length of the Director 3	0.35λ
Spacing between Directors	0.2λ
Reflector to dipole spacing	0.35λ
Dipole to Director spacing	0.125λ

If the specifications given above are followed, one can design an Yagi-Uda antenna.

Radiation Pattern

The directional pattern of the Yagi-Uda antenna is **highly directive** as shown in the figure given below.

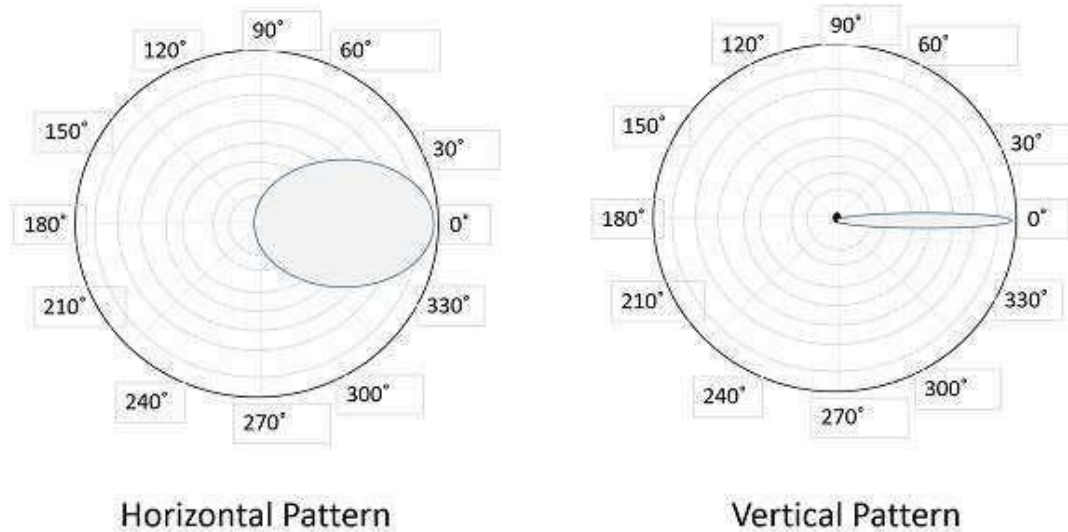

The minor lobes are suppressed and the directivity of the major lobe is increased by the addition of directors to the antenna.

Advantages

The following are the advantages of Yagi-Uda antennas-

- High gain is achieved.
- High directivity is achieved.
- Ease of handling and maintenance.
- Less amount of power is wasted.
- Broader coverage of frequencies.

Disadvantages

The following are the disadvantages of Yagi-Uda antennas-

- Prone to noise.
- Prone to atmospheric effects.

Applications

The following are the applications of Yagi-Uda antennas-

- Mostly used for TV reception.
- Used where a single-frequency application is needed