



**3. State the difference between Envelope Detector and Square law Detector ?**  
**[2016]**

Envelope Detector:- Envelope detector is used to detect DSB-FC signal. It operates in linear region of the diode characteristics.

Square Law Detector:- Square law detector is used to detect very low level signal. It operates in non linear region of diode characteristics.

**Long Questions (5marks & 7 marks)**

**1. With neat block diagram Explain the Balanced Modulator of DSB-SC generation?**

**[2015 /2017]**

Balance modulator may be defined as a circuit in which two non linear device are connected in a balance mode to generate a DSB-SC signal. We know that the nonlinear device, diode or transistor may be used in this circuit. For amplitude modulation to generate DSB-FC signal. If two nonlinear device are connected in balance mode so as to suppress the carrier of each other, then only side bands are produce(DSB-SC).The balance modulator circuit can be constructed with the help of two diodes or two transistors.

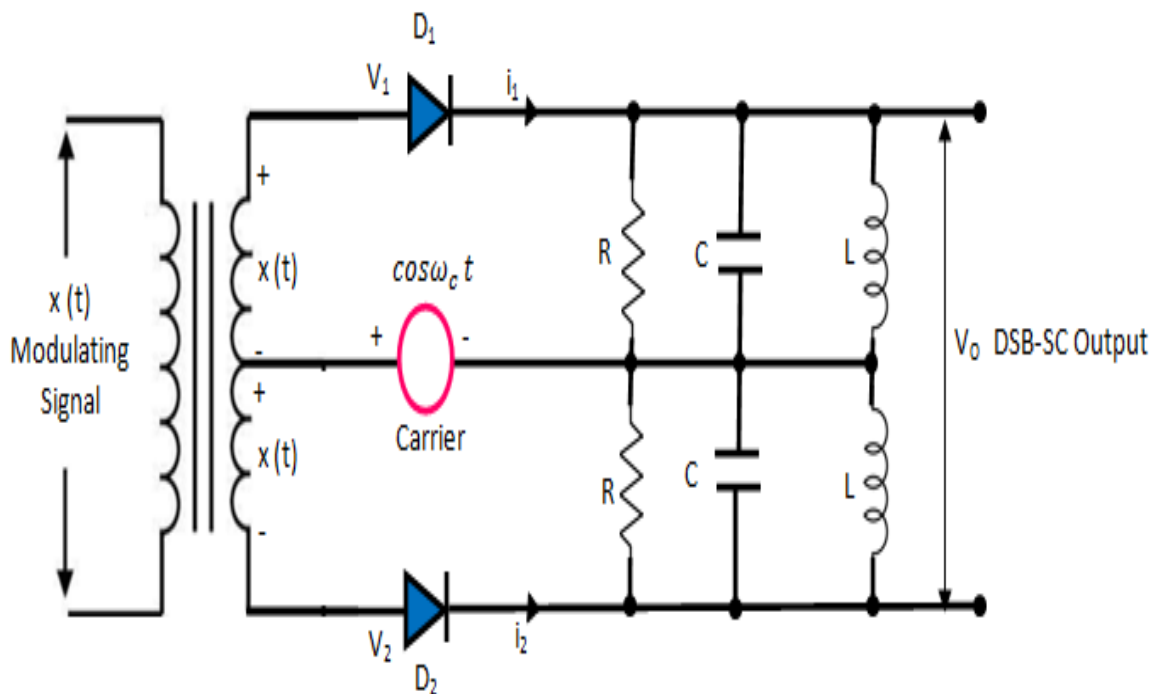

The diode or transistor used in the circuit are identical characteristics and the circuit is symmetrical with respect to center tap of the transformer . As two halves to be matched or balanced such a modulator is known as balanced modulator. The modulating signal  $E_m \sin \omega_m t$  is applied in the primary of the transformer and the carrier RF signal  $E_c \sin \omega_c t$  is put in parallel to a pair of identical diodes  $D_1$  and  $D_2$ . A band pass filter used in diode circuit which allows to pass a particular band of frequency only .Since the band pass filter is concentrated around  $\pm \omega_c$ , it will pass a narrow band of frequency.

## 2. Describe the operation of Linear diode detector / envelope detector ?

[ 2015 /2016 /2017 ]

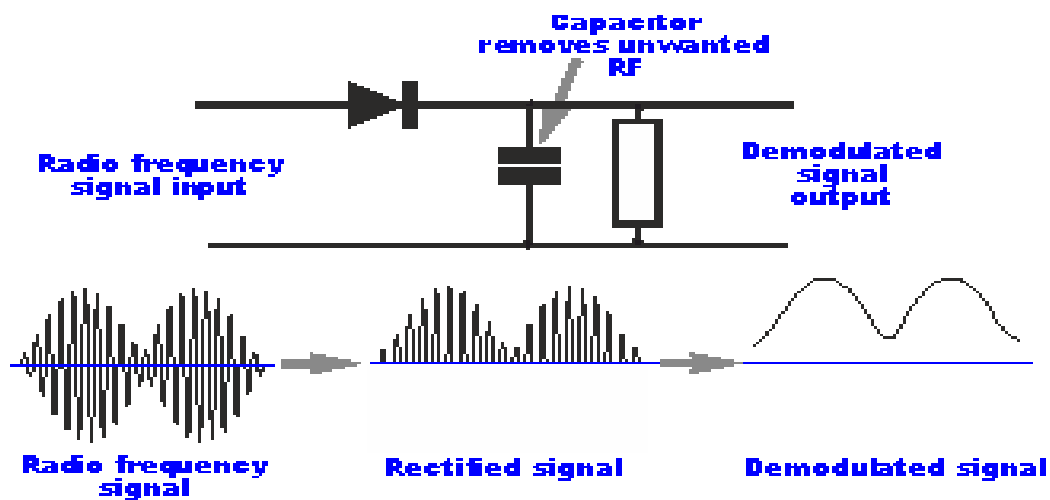

Diode detector is called envelope detector as it recovers the audio frequency signal envelope from the composite signal. Diode detector is called linear detector as its output is proportional to the voltage of the input signal. Antenna receives different modulated waves which were transmitted by different transmitters. The desired modulated wave is selected by a tuned RF amplifier which consists of a tank circuit  $L_1$  &  $C_1$ .

The diode detector consists of a rectifier circuit and an RF filter circuit. The half-wave rectifier rectifies the +ve half cycle of the modulated wave. The -ve half cycle is removed. The varying +ve half cycle contains the carrier wave and the low-frequency modulating wave. When these +ve half cycles are applied to the RC filter, the carrier components are removed, and the output is a low-frequency modulating signal.

## 3. State multiplexing, Explain operation of frequency division multiplexing ?

[2015/ 2016 /2017]

Multiplexing is a technique in which numbers of signals are transmitted in one channel. The different types of multiplexing are TDM & FDM. FDM means Frequency Division Multiplexing. In this technique, numbers of signals are transmitted in the channel and they are separated in the frequency domain. In FDM, the signals are separated by different frequency ranges. In FDM, the frequency spectra of various signals are shifted in such a way that they occupy different frequency bands in a channel without overlapping. In FDM, the available channel bandwidth is divided into different non-overlapping frequency bands. Then each band is allocated to different message signals by one of the analog modulation methods.

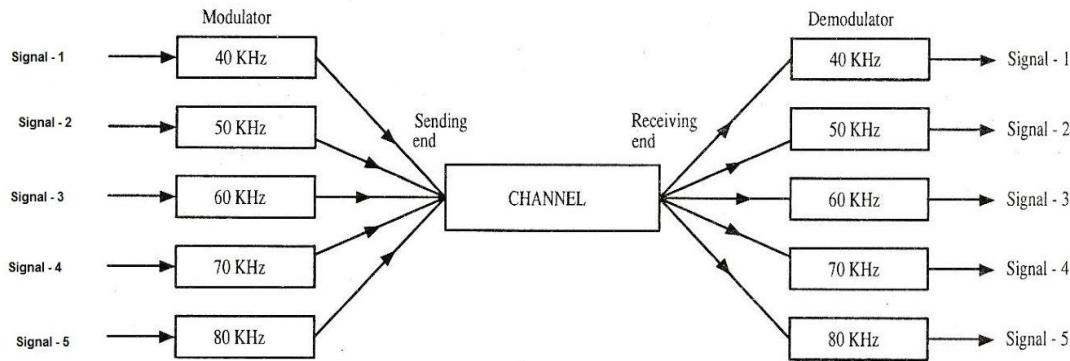

Figure 1. Frequency division multiplexing

Then modulated signal are summed to produced composite multiplexed signal. The composite modulated signal is modulated by once again if necessary otherwise transmitted directly over the single channel. In receiving end individual signals are extracted from FDM signal by appropriate filtering.

## **CHAPTER-3**

### **Long Questions (5marks & 7 marks)**

#### **1. Discuss comparison between AM and FM modulation ? [2015]**

1. In AM amplitude of the carrier changes, where phase and frequency remains constant.	1. In FM frequency of the carrier changes but amplitude and phase remains constant.
2. It has two side bands.	2. It has infinite numbers of side band.
3. The system is simple.	3. The system is complex.
4. More chance of noise and distortion.	4. Less chance of noise and distortion.

#### **2. Describe parameter variation method of FM generation / Direct method of frequency modulation ? [2017]**

In this method the instantaneous frequency of the carrier is varied directly in accordance with the base band signal by means of a device known as voltage controlled oscillator (VCO) .If the capacitance is varied the frequency may be changed . Varactor diode may also be used frequency modulation.

## Reactance modulator

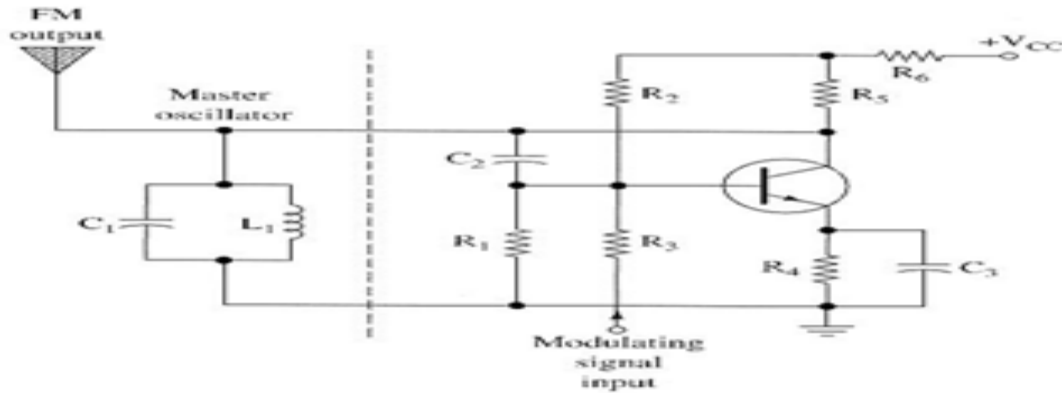

EKT343 – Principle of C Engineering

It is seen that the diode has been reverse biased to provide junction capacitance effects and this bias is varied by the modulating voltage which is in series with it, the junction capacitance will also vary, causing the oscillator frequency to change accordingly, thereby generating FM signal.

### 3. With neat diagram describe the principle of operation of FM foster seeley discriminator ?

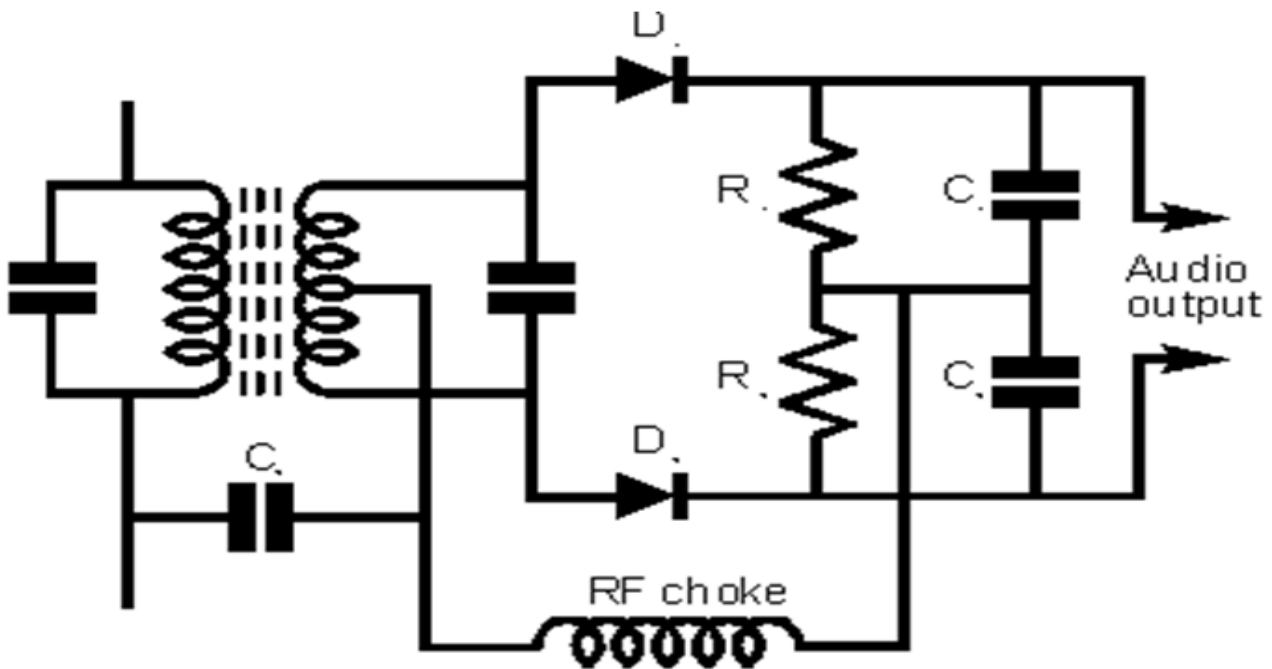

**The Foster-Seeley discriminator / detector**

Foster-seeley detector or discriminator recovers the modulating voltage from the frequency modulated wave by utilizing the phase angle shift between primary and secondary voltage of a tuned transformer. The phase angle is a function of frequency. The arrangement will be made to get sum and difference of primary and secondary voltage and the resultant voltage is applied to the envelope detector to get the base band signal. The circuit consists of an inductively coupled double-tuned circuit in which both primary and secondary coils are tuned to the same frequency. The center of the secondary coil is connected to the top of primary

through the capacitor C. The primary voltage  $V_3$  appears across the inductor  $L_2$ . Nearly entire voltage  $V_3$  appears across the inductor  $L_3$  except a small drop across the capacitor. However a suitable choice of L and C the voltage drop across the capacitor C can be negligible. The entire taping of the secondary coil has an equal and opposite voltage across each half winding. Hence  $v_1$  and  $v_2$  are equal in magnitude but opposite in phase. The radio frequency voltage  $v_{a1}$  and  $v_{a2}$  applied to the diode  $D_1$  and  $D_2$  are expressed as  $V_{a1} = V_3 + V_1$  and  $v_{a2} = V_3 - V_2$ . The phasor  $v_1$  and  $v_2$  are always equal in magnitude but opposite in phase.

### Case-1(At Resonance)

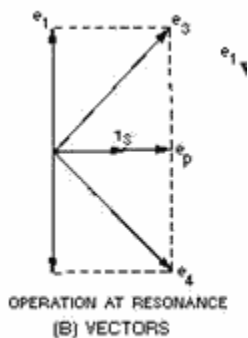

When input frequency is same as resonant frequency of the tuned circuit  $V_3$  is in phase quadrature with  $v_1$  and  $v_2$ . The resonant voltage  $v_{a1}$  and  $v_{a2}$  are equal in magnitude.

### Case-2( Below Resonance)

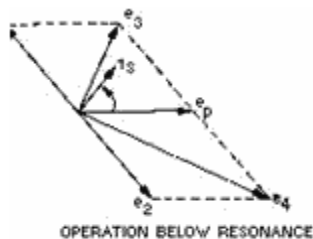

If the input frequency is greater than resonant frequency, the phase difference between  $v_1$  and  $v_3$  is less than  $90^\circ$ . Here  $V_{a1}$  is reduced and  $v_{a2}$  is increased. The phase difference between  $v_1$  and  $v_3$  is  $< 90^\circ$  and between  $v_2$  and  $v_3$  is  $> 90^\circ$ .

### Case-3( operation above Resonance)

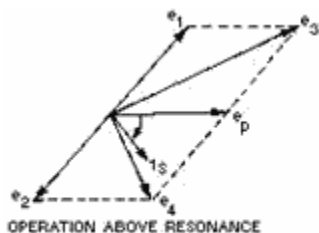

When input frequency is greater than resonant frequency phase difference between  $v_1$  and  $v_3$  is  $> 90^\circ$  and phase difference between  $v_2$  and  $v_3$  is  $< 90^\circ$ . From this figure the resonant  $v_{a1}$  is increased where as  $v_{a2}$  is reduced. The RF voltage  $v_{a1}$  and  $v_{a2}$  are separately rectified by the diode  $D_1$  and  $D_2$  respectively to provide voltage  $v_{out1}$  and  $v_{out2}$ . Thus the output will be

$$V_{out} = |V_{out1}| - |V_{out2}|$$

#### 4. Derive an expression for power relation in AM

Let the modulating signal

$$e_m = E_m \sin \omega_m t$$

Let the carrier wave is represented by an expression  $e_m = E_m \sin \omega_m t$

From the definition it is clear that the amplitude of the carrier is varied in accordance with modulating signal

The amplitude of the modulated wave is given as

$$A = E_c + e_m$$

$$= E_c + E_m \sin \omega_m t$$

$$= E_c \left( 1 + \frac{E_m}{E_c} \sin \omega_m t \right)$$

$$= E_c (1 + m_a \sin \omega_m t)$$

Where  $m_a = \frac{E_m}{E_c}$  is called modulation index or depth of modulation.

It is a number laying between zero and one, when it is expressed as a percentage is called percentage of modulation.

Hence the resultant modulated wave is

$$e_{Am}(t) = A \sin \theta = A \sin \omega_c t$$

$$= E_c (1 + m_a \sin \omega_m t) \sin \omega_c t$$

$$= E_c \sin \omega_c t + \frac{m_a E_c}{2} \cos(\omega_c - \omega_m) t - \frac{m_a E_c}{2} \cos(\omega_c + \omega_m) t$$

$$\text{Or } e_{Am}(t) = E_c \sin \omega_c t + \frac{m_a E_c}{2} \cos(\omega_c - \omega_m) t - \frac{m_a E_c}{2} \cos(\omega_c + \omega_m) t$$

The first term is unmodulated carrier, the two additional terms produced are the two side bands, the frequency of the lower side band is  $(\omega_c + \omega_m)$  and the frequency of upper band is  $(\omega_c - \omega_m)$

The three components present in Am wave

1. unmodulated carrier

2. Upper side band

3. Lower side band

The amplitude of the modulated carrier varies as

$$A = E_c (1 + m_a \sin \omega_m t)$$

The max and min values of A are  $E_{max} = E_c (1 + m_a)$

$$E_{min} = E_c (1 - m_a)$$

This gives  $m_a = \frac{E_{max} - E_{min}}{E_{max} + E_{min}}$

Power relation :-

Modulated carrier wave contain more power as compared to unmodulated wave because it contains two more side bands .The amplitude of side band depends upon the modulation index ,it is anticipated that the total power in the modulated wave will depend on the modulation index .

$$\text{The total power } P_t = \frac{E_{carrier}^2}{R} + \frac{E_{LSB}^2}{R} + \frac{E_{USB}^2}{R}$$

Where LSB and USB denote lower side band and upper side band and R is the equivalent resistance of antenna

$$\frac{E_{carrier}^2}{R} = \frac{\left(\frac{E_C}{\sqrt{2}}\right)^2}{R} = \frac{E_C^2}{2R}$$

$$\text{and } \frac{E_{LSB}^2}{R} = \frac{E_{USB}^2}{R} = \frac{\left(\frac{m_a E_C}{2\sqrt{2}}\right)^2}{R} = \frac{m_a^2 E_C^2}{8R}$$

The total power of a modulated carrier

$$\begin{aligned} P_t &= \frac{E_C^2}{2R} + \frac{m_a^2 E_C^2}{8R} + \frac{m_a^2 E_C^2}{8R} \\ &= \frac{E_C^2}{2R} \left[1 + \frac{m_a^2}{2}\right] \\ P_t &= P_C \left[1 + \frac{m_a^2}{2}\right] \end{aligned}$$

Where  $p_t$  =unmodulated carrier power

## **CHAPTER-4**

### **2 marks questions**

#### **1. Define selectivity and sensitivity of receiver ? [ 2016/ 2017 ]**

**Selectivity:-** The selectivity of a receiver is its ability to reject unwanted signals.

**Sensitivity:-** The sensitivity of a radio receiver is its ability to amplify the weak signal . It is also defines in terms of the voltage that must be applied to the receiver input terminals to give a standard output power measured at the output terminal.



## Long Questions (5marks & 7 marks)

### 1. State the working of FM receiver with block diagram ?[ 2016/ 2017 ]

The FM receiver is more complicated and expensive than AM receiver .The FM broad cast frequency range lies in between 88 MHz to 108 MHz. The IF of an FM receiver is 10.7 MHz .

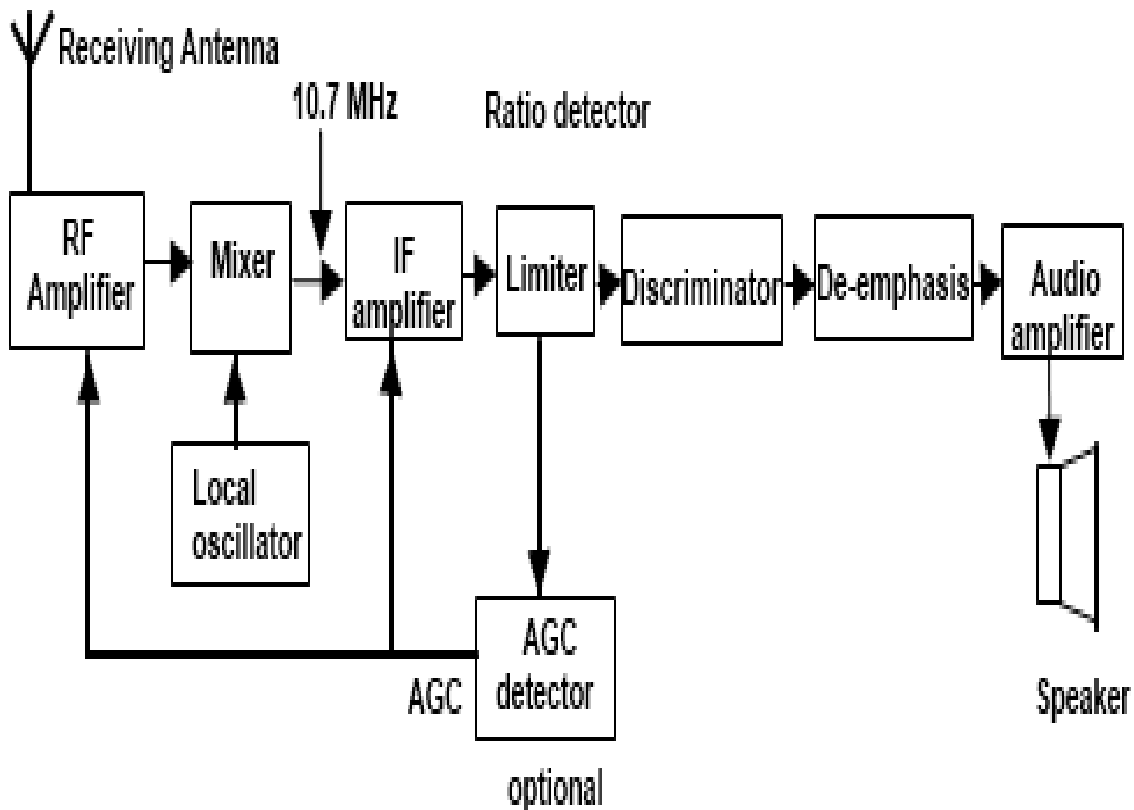

- **RF Tuner:-** The FM signals are in the frequency range 88 MHz to 108 MHz . The weak FM signal is picked up by an antenna and is fed to the FM tuner . The RF tuner consists of a mixer, RF amplifier and local oscillator . The RF amplifier amplifies the RF signal and fed to the mixer stage , which is combined with the output stage of the local oscillator. These two frequency produces the IF frequency at the output of the mixer .
- **IF Amplifier stage:-** The IF is always 10.7 MHz.The output of the mixer is amplified in the IF amplifier stage . The band width of IF amplifier is 200 KHz or 0.2 MHz . The output is 2 v.
- **Limiter stage:-** The output of the IF amplifier is fed to the limiter stage . The main function is to remove AM interference from FM signal . The limiter circuit keep the output level constant for different input levels.

- **FM Detector:-** The output of the limiter is fed to the detector stage . The FM detector converts the frequency variation to amplitude variation. It distinguishes between different frequencies in the input to provide different output voltage. The output of the FM detector is fed to the loud speaker.

**2. With proper diagram describe the operation of Super heterodyne radio receiver ? [ 2016 /2017 / 2017 ]**

The antenna receives different modulated wave which are transmitted by different transmitter.

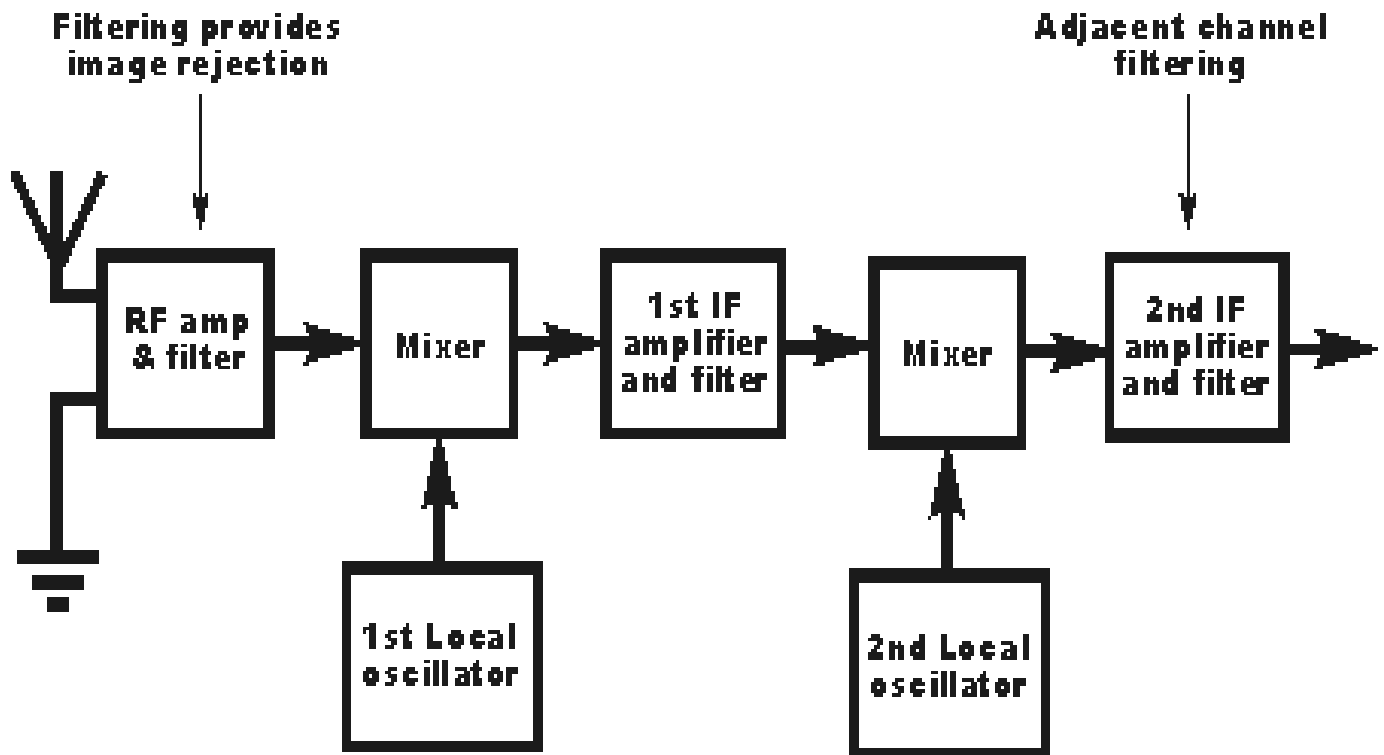

**[BLOCK DIAGRAM OF SUPER HETERODYNE RADIO RECEIVER]**

- **RF Amplifier:-** The RF amplifier stage uses a tuned parallel circuit  $L_1C_1$  with a variable capacitor  $C_1$  . The radio wave from various broad casting stations are intercepted by the receiving antenna and couple this stage . This stage select the desired frequency signal and amplify the signal if necessary.
- The output of RF amplifier and output of local oscillator is fed to the mixer circuit. The mixer circuit beat two frequency signal and produce a constant frequency output which is known as IF signal (Intermediate Frequency). For AM modulation  $IF=455$  KHz .

$$IF= \text{Oscillator frequency} - \text{Radio Frequency}$$

- **IF Amplifier:-** The output of mixer is always 455 KHz and fed to tuned IF amplifier . This amplifier amplify the IF signal.
- **Detector:-** The detector circuit perform demodulation . Here original audio signal is extracted from modulated wave. Here diode detector is used for low distortion .
- **AF Amplifier:-** The audio signal output of detector stage is fed to multistage audio amplifier . Here the signal is amplified .
- **Loud Speaker:-** It is the transducer which convert electrical energy into sound energy . Here original output is obtained.

### 3. Explain working of Steriophonic FM Transmitter ? [ 2016 ]

#### Stereo Broadcast Transmission

A block diagram of a typical frequency stabilizing system used is shown in Figure. It uses a basic frequency, Standard, a crystal oscillator, and the carrier frequency of the FM signal is compared with it. We know that reactance modulator works across the tank circuit of a LC oscillator, whose output is isolated by a buffer stage. The output of buffer is fed to an amplitude limiter and subsequently to the class C power amplifiers (not shown).

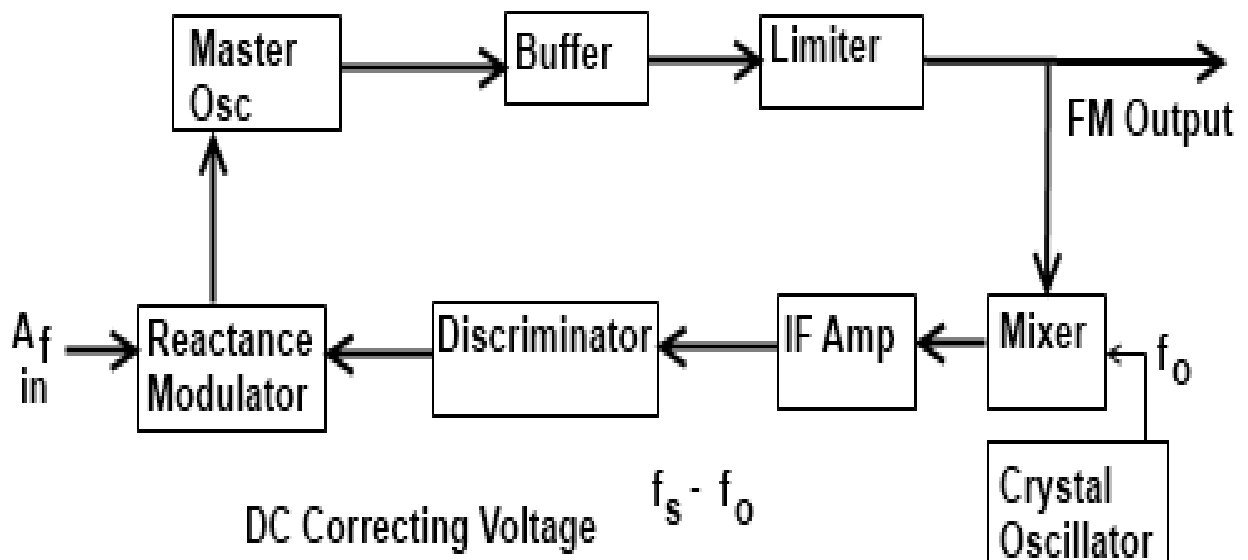

Stereo  
Broadcast  
Transmission

A small portion of the signal is taken from the limiter output and fed to mixer in which this signal is mixed with a signal from the crystal oscillator. The difference signal which is usually about one-tenth- to one-twentieth of the master oscillator frequency is amplified and applied to a phase

discriminator. The output of the phase discriminator is a DC signal which is applied to the reactance modulator as a correcting voltage to counteract any drift in the average frequency of the master oscillator.

The discriminator is so designed that it reacts to slow changes in the incoming frequency, but not to the normal frequency variation due to frequency modulation. Also the discriminator provides positive O/p voltage if the input frequency exceeds the discriminator tuned frequency and 0 negative O/p voltage, if it is lower.

A stereo signal consists of two channels which can be labeled L and R (left and right), once channel for each speaker. The ordinary mono signal consists of the summation of the two channels, i.e.  $L + R$ , and this can be transmitted in the normal way. If a signal containing the difference between the left and right channels,  $L - R$ , is transmitted then it is possible to reconstitute the left and right only signals. By adding the sum and difference signals i.e.  $(L + R) + (L - R)$ , gives  $2L$ , i.e. the left signal.

and subtracting the two signals, i.e.  $(L + R) - (L - R)$  gives  $2R$ , the right signal. This can be achieved relatively simply by adding and subtracting signals electronically. It only remains to find a method of transmitting the stereo difference signal in a way that does not affect any mono receivers.

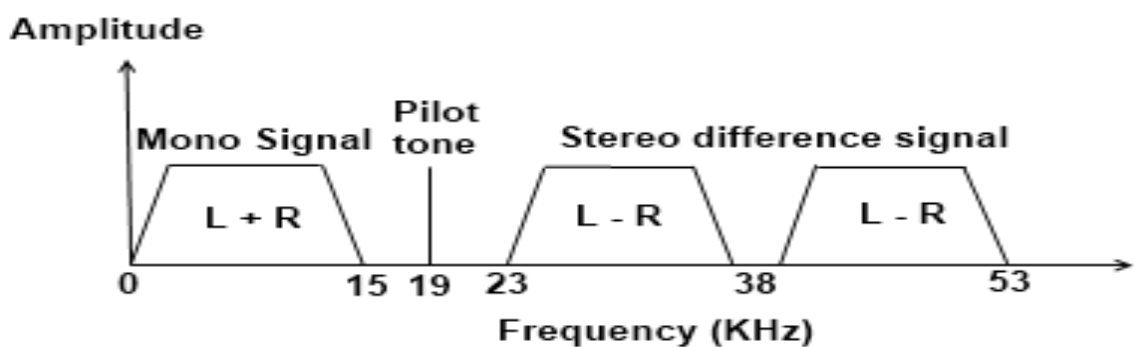

**The modulating, (base-band) signal for a stereo VHF F.M transmission**

**Stereo  
Broadcast  
Transmission  
Sideband**

This is achieved by transmitting the difference signal above the audio range. It is amplitude modulated onto a 38 KHz sub-carrier. Both the upper and lower side-bands are retained, but the 38.

KHz sub-carrier itself is suppressed to give a double side-band signal above the normal audio bandwidth as shown in Figure. This whole base-band is used to frequency modulate the final radio frequency carrier.

To regenerate the 38 KHz sub-carrier, a 19 KHz pilot tone is transmitted. The frequency of this is doubled in the receiver to give the required 38 KHz signal to demodulate the double side-band stereo difference signal. The frequency of pilot tone is also used to detect whether a stereo signal is being transmitted. If it is not present, the stereo reconstituting circuitry is turned off. However, when it is present, the stereo signal can be constituted.

To generate the stereo signal, a system similar to that shown in Figure is used. The left and right signals enter the encoder where they are passed through a circuit to add the required pre-emphasis. After this they are passed into a matrix circuit. This adds and subtracts the two signals to provide the  $L + R$  and  $L - R$  signals. The  $L + R$  signal is passed straight into the final summation circuit to be transmitted as the ordinary mono audio. The difference  $L - R$  signal is passed into a balanced modulator to give the double side-band suppressed carrier signal centered on 38 KHz. This is passed into the final summation circuit as the stereo difference signal. The other signal entering the balanced modulator is a 38 KHz signal which has been obtained by doubling the frequency of the 19 KHz pilot

Tone. The pilot tone itself is also passed into the final summation circuit. The final modulating signal consisting of the  $L + R$  mono signal, 19 KHz pilot tone, and the  $L - R$  difference signal based around 38 KHz is then used to frequency modulate the radio frequency carrier before being transmitted.

### **3. Explain working of Steriophonic FM Receiver ? [ 2015 / 2017 ]**

#### **Stereo FM Receiver**

A stereo FM receiver has three major sections:

- Mono mode
- Stereophonic mode
- Section common to both mono and stereo modes

The section that is common to both mono and stereo modes is a standard FM receiver that recovers the modulating signal. The output of this section is routed to the remaining two sections. The output consists of both the left and right channel marked as  $(L + R)$  in Figure. This output is applied to the mono section and the speaker produces audio signals in monophonic mode.

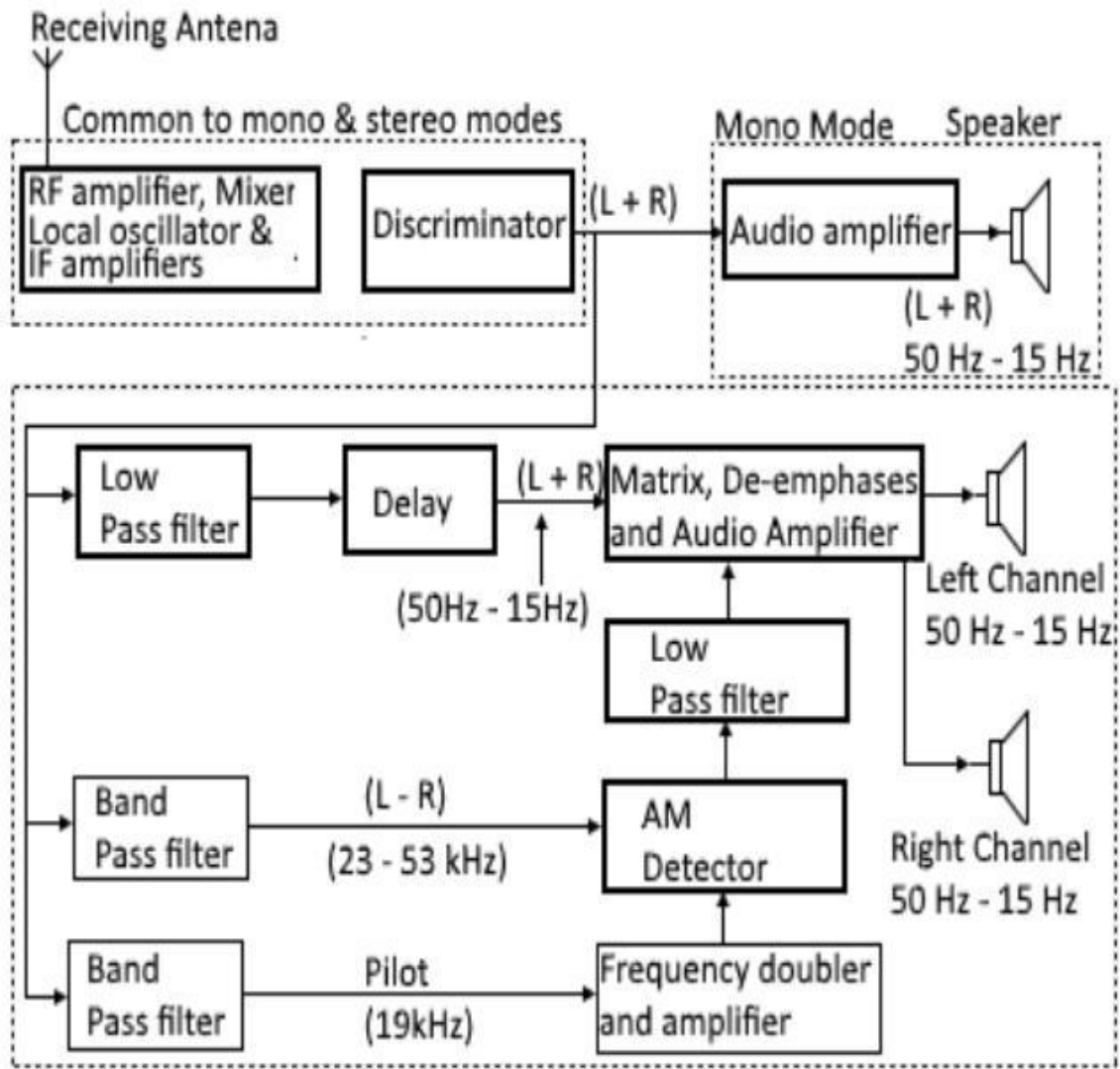

**Stereo FM Receiver Block Diagram**

The stereo section is more complicated. It uses three filters to extract  $(L + R)$  and  $(L - R)$  signals and the pilot-carrier from the discriminator output. The  $(L + R)$  signal is obtained from the low-pass filter, which contains frequencies between 50 Hz and 15 kHz. This signal delayed for a fixed time before applying it to the matrix and the de-emphasis network. This is done to simultaneously get the  $(L + R)$  and  $(L - R)$  signals at the matrix. The matrix network separates the left (L) and right (R) channels. These are then de-emphasized and amplified by the audio amplifiers and are given to their respective speakers.

A band pass filter is used to extract the  $(L - R)$  signal varying between 23-53 kHz. It is a double-side band (DSB) signal. This signal is applied to an AM detector to demodulate. The transmitter uses a 38 kHz carrier signal to get a DSB-SC signal from the  $(L - R)$  signal. Thus, at the receiver, a carrier of 38 kHz is required to demodulate the received  $(L - R)$  signal.

The pilot carrier of 19 kHz is extracted using another band pass filter. This pilot carrier is given to the frequency doubler, which doubles its frequency to 38 kHz. After amplification of this The AM detector detects the (L - R) signal, which is carrier, it is applied to the AM detector matrix. As some time is taken for the (L - R) signal to demodulate, the (L + R) signal is delayed so that both (L + R) and (L - R) reach the matrix at the same time.

## **CHAPTER-5**

### **2 marks questions**

#### **1. Write down disadvantages of Delta modulation ? [2016]**

The disadvantages of delta modulation are

- Slope overload Distortion
- Granular or Ideal noise

#### **2. State Sampling Theorem and classify Sampling. [2015]**

The sampling rate of sampling process should greater than or equal to twice of maximum signal frequency to be sampled recover the signal with minimum distortion.

$$F_s \geq 2 F_m$$

Classification of Sampling:

- Instantaneous sampling
- Natural sampling
- Flat top sampling

#### **3. What is Repeater , why it is essential?[2016]**

Repeater is used in transmission line to receiver the signal strength in different interval.

### **Long Questions (5marks & 7 marks)**

#### **1. Discuss the term sampling and Nyquist rate, Nyquist interval, Aliasing ? [2016 / 2017]**

**Sampling:-**The process of measuring the signal value at discrete time interval is known as sampling. The individual signal strength at a particular time instant after sampling is known as sampling.

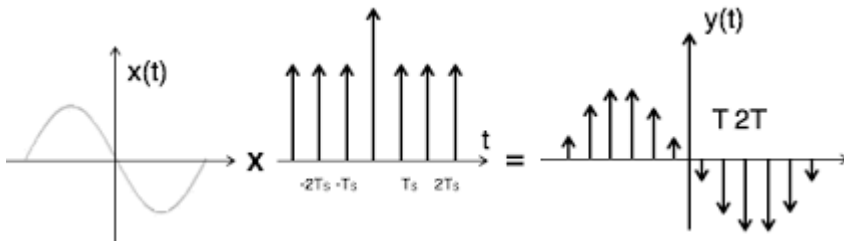

**Nyquist rate:-** The minimum sampling rate  $F_s=2 F_m$  is called Nyquist rate.

**Nyquist Interval:-** When  $F_s=2 F_m$ , the interval between two sample are known as Nyquist Interval.

**Aliasing:-** This is the distortion due to improper sampling . When sampling rate  $F_s$  is less than twice of maximum frequency of max. frequency component ( $F_s < 2 F_m$  )

The side bands of the signal overlap and the signal  $x(t)$  can not be recovered without distortion . This distortion is called aliasing effect. To avoid aliasing effect sampling rate must be  $F_s \geq 2 F_m$  .

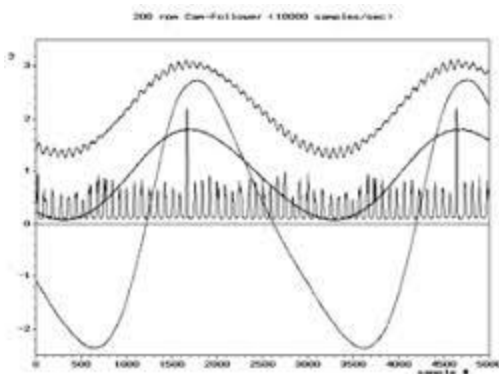

## **2.Describe the operation of PAM modulation ?**

**[2015 /2016/ 2017]**

Pulse Amplitude Modulation is the simplest form of pulse modulation technique . PAM is a pulse modulation system in which the signal is sampled at regular intervals and each sample is made proportional to the amplitude of the signal at the instant of sampling. The PAM representation is shown in fig-a shows single polarity PAM fig-b shows double polarity PAM.



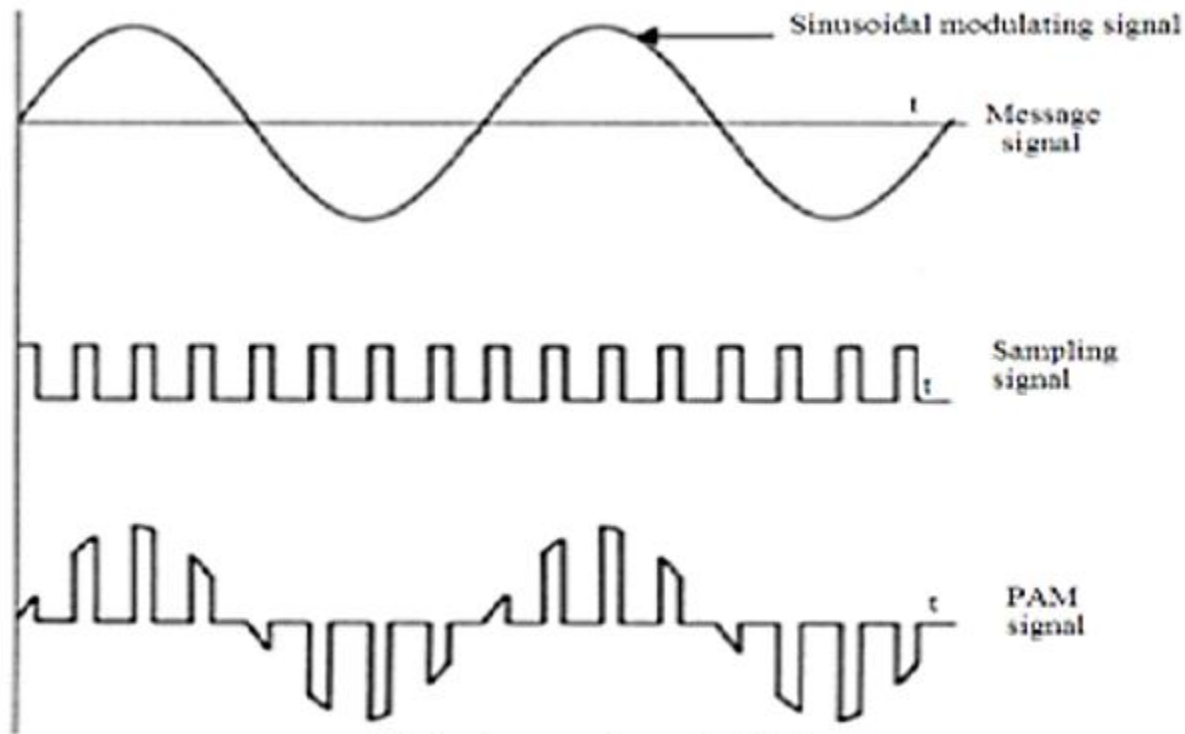

Fig1. Generation of PAM

In single polarity PAM a fixed dc level is added to the signal to ensure that the pulse are always positive . In double polarity PAM the pulses appear both in positive and negative side

Sometimes pulses tops are made to follow the analog signal envelope.This is refered as natural PAM sampling. Sometimes the tops of pulses are retain as flat top , in this case the flat top is refered as flat top sampling.

In PAM the width of the pulses and passion of the pulse are remain constant.

It is very easy to generate and demodulate the PAM . In generator ,the signal to be converted to PAM is fed to one input of an AND gate . The pulses at sampling frequency are applied to the other input of AND gate to open it during the wanted time intervals. The output of AND gate is in the form of pulses at sampling rate with an amplitude proportional to the magnitude of the modulating signal at each instant . The pulses are then passed through apulse shaping network which makes them flat top.

### **3.describe the working of PWM communication system ?**

**[2016]**

The pulse width modulation is also known as pulse duration modulation . In this modulation the pulse width is proportional to the amplitude of the modulating signal. In this type we have a fixed amplitude and starting time of each pulse is made proportional to the amplitude of the signal at that instant . PWM can be generated by applying trigger pulse at sampling rate to control the starting time of pulse from a monostable multivibrator and feeding in the modulating signal to be sampled to control the duration of these pulses.

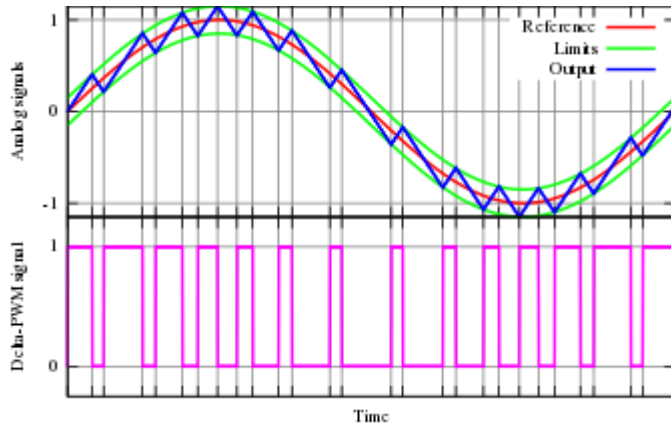

#### **4. Classify digital modulation Technique ? [2017]**

Analog pulse Technique:-

PAM-Pulse Amplitude Modulation

PDM- Pulse Duration Modulation

PPM- Pulse Position Modulation

In this modulation system modulating signal is a analog signal and carrier is digital pulse.

Digital Pulse Modulation:-

PCM- Pulse Code Modulation

DM- Delta Modulation

DPCM-Differential Pulse Code Modulation

ADM-Adaptive Delta Modulation

Digital modulation:-

ASK-Amplitude Shift Keying

FSK- Frequency Shift Keying

PSK- Phase Shift Keying

QPSK- Quadrature Phase Shift Keying

BPSK- Binary Phase Shift Keying

In this modulation technique modulating signal is digital but carrier is analog signal.

## 5. Describe the Generation of delta modulation? [2015 / 2017]

A delta modulation (DM or  $\Delta$ -modulation) is an [analog-to-digital](#) and [digital-to-analog signal](#) conversion technique used for transmission of voice information where quality is not of primary importance. DM is the simplest form of [differential pulse-code modulation](#) (DPCM) where the difference between successive samples are encoded into n-bit data streams. In delta modulation, the transmitted data are reduced to a 1-bit data stream. Its main features are:

- The analog signal is approximated with a series of segments.
- Each segment of the approximated signal is compared of successive bits is determined by this comparison.
- Only the change of [information](#) is sent, that is, only an increase or decrease of the signal amplitude from the previous sample is sent whereas a no-change condition causes the modulated signal to remain at the same 0 or 1 state of the previous sample.

### Illustration of delta modulation.

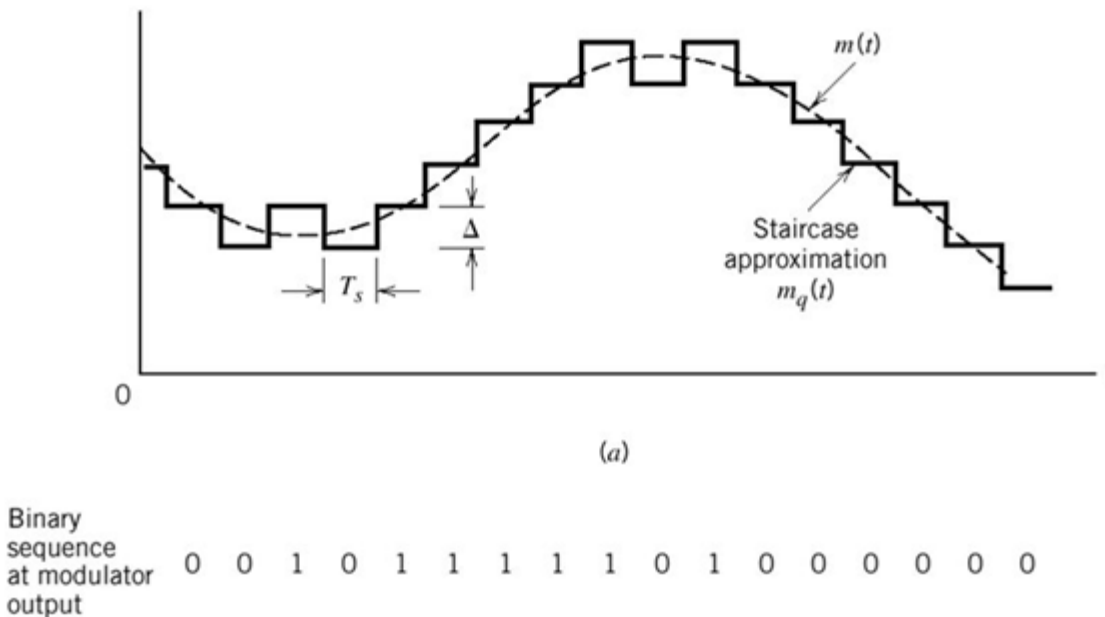

## 6. Describe the working of PCM modulator and PCM Demodulator ?[2016/ 2017]

Pulse-code modulation (PCM) is a method used to [digitally](#) represent sampled [analog signals](#). It is the standard form of [digital audio](#) in computers, [compact discs](#), [digital telephony](#) and other digital audio applications. In a PCM [stream](#), the [amplitude](#) of the analog signal is [sampled](#) regularly at uniform intervals, and each sample is [quantized](#) to the nearest value within a range of digital steps.

Linear pulse-code modulation (LPCM) is a specific type of PCM where the quantization levels are linearly uniform.<sup>[5]</sup> This is in contrast to PCM encodings where quantization levels vary as a function of amplitude (as with the [A-law algorithm](#) or the [μ-law algorithm](#)). Though PCM is a more general term, it is often used to describe data encoded as LPCM.

A PCM stream has two basic properties that determine the stream's fidelity to the original analog signal: the [sampling rate](#), which is the number of times per second that samples are taken; and the [bit depth](#), which determines the number of possible digital values that can be used to represent each sample.

## Modulation

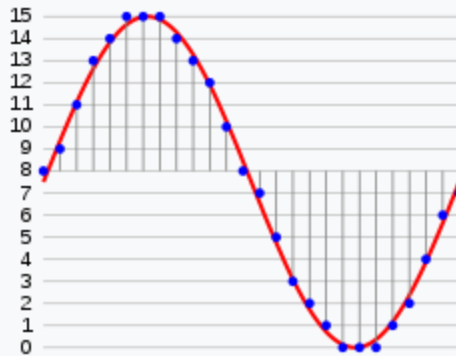

### Sampling and quantization of a signal (red) for 4-bit LPCM

In the diagram, a [sine wave](#) (red curve) is sampled and quantized for PCM. The sine wave is sampled at regular intervals, shown as vertical lines. For each sample, one of the available values (on the y-axis) is chosen by some algorithm. This produces a fully discrete representation of the input signal (blue points) that can be easily encoded as digital data for storage or manipulation. For the sine wave example at right, we can verify that the quantized values at the sampling moments are 8, 9, 11, 13, 14, 15, 15, 14, etc. Encoding these values as [binary numbers](#) would result in the following set of [nibbles](#): 1000 ( $2^3 \times 1 + 2^2 \times 0 + 2^1 \times 0 + 2^0 \times 0 = 8 + 0 + 0 + 0 = 8$ ), 1001, 1011, 1101, 1110, 1111, 1111, 1111, 1110, etc. These digital values could then be further processed or analyzed by a [digital signal processor](#). Several PCM streams could also be [multiplexed](#) into a larger aggregate [data stream](#), generally for transmission of multiple streams over a single physical link. One technique is called [time-division multiplexing](#) (TDM) and is widely used, notably in the modern public telephone system.

The PCM process is commonly implemented on a single [integrated circuit](#) generally referred to as an [analog-to-digital converter](#) (ADC).

## Demodulation

To recover the original signal from the sampled data, a "demodulator" can apply the procedure of modulation in reverse. After each sampling period, the demodulator reads the next value and shifts the output signal to the new value. As a result of these transitions, the signal has a significant amount of high-frequency energy caused by [aliasing](#). To remove these undesirable frequencies and leave the original signal, the demodulator passes the signal through analog filters that suppress energy outside the expected frequency range (greater than

the [Nyquist frequency](#) ).<sup>[note 3]</sup> The [sampling theorem](#) shows PCM devices can operate without introducing distortions within their designed frequency bands if they provide a sampling frequency twice that of the input signal. For example, in [telephony](#), the usable [voice](#) frequency band ranges from approximately 300 Hz to 3400 Hz. Therefore, according to the [Nyquist–Shannon sampling theorem](#), the sampling frequency (8 kHz) must be at least twice the voice frequency (4 kHz) for effective reconstruction of the voice signal.

The electronics involved in producing an accurate analog signal from the discrete data are similar to those used for generating the digital signal. These devices are [Digital-to-analog converters](#) (DACs). They produce a [voltage](#) or [current](#) (depending on type) that represents the value presented on their digital inputs. This output would then generally be filtered and amplified for use.

# CHAPTER-6

## 2 marks question

### **1. State Shanons theorem ? [2017]**

Shannon's Theorem gives an upper bound to the capacity of a link, in bits per second (bps), as a function of the available bandwidth and the signal-to-noise ratio of the link.

The Theorem can be stated as:

$$C = B * \log_2(1 + S/N)$$

where C is the achievable channel capacity, B is the bandwidth of the line, S is the average signal power and N is the average noise power.

The signal-to-noise ratio (S/N) is usually expressed in decibels (dB)

## Long Questions (5marks & 7 marks)

### **1. Describe the operation of ASK modulator and ASK Demodulator ?**

**[2015]**

Amplitude-shift keying (ASK) is a form of **amplitude modulation** that represents **digital data** as variations in the **amplitude** of a **carrier wave**. In an ASK system, the binary symbol 1 is represented by transmitting a fixed-amplitude carrier wave and fixed frequency for a bit duration of T seconds. If the signal value is 1 then the carrier signal will be transmitted; otherwise, a signal value of 0 will be transmitted.

Any digital modulation scheme uses a **finite** number of distinct signals to represent digital data. ASK uses a finite number of amplitudes, each assigned a unique pattern of **binary digits**. Usually, each amplitude encodes an equal number of bits. Each pattern of bits forms the **symbol** that is represented by the particular amplitude. The **demodulator**, which is designed specifically for the symbol-set used by the modulator, determines the amplitude of the received signal and maps it back to the symbol it represents, thus recovering the original data. **Frequency** and **phase** of the carrier are kept constant.

Like **AM**, an ASK is also linear and sensitive to atmospheric noise, distortions, propagation conditions on different routes in **PSTN**, etc. Both ASK modulation and demodulation processes are relatively inexpensive. The ASK technique is also commonly used to transmit **digital data** over optical fiber. For LED transmitters, binary 1 is represented by a short pulse of light and binary 0 by the absence of light. Laser transmitters normally have a fixed "bias" current that causes the device to emit a low light level. This low level represents binary 0, while a higher-amplitude lightwave represents binary 1.

The simplest and most common form of ASK operates as a switch, using the presence of a carrier wave to indicate a binary one and its absence to indicate a binary zero. This type of modulation is called **on-off keying** (OOK), and is used at radio frequencies to transmit Morse code (referred to as continuous wave operation),

More sophisticated encoding schemes have been developed which represent data in groups using additional amplitude levels. For instance, a four-level encoding scheme can represent two bits with each shift in amplitude; an eight-level scheme can represent three bits; and so on. These forms of amplitude-shift keying require a high signal-to-noise ratio for their recovery, as by their nature much of the signal is transmitted at reduced power.

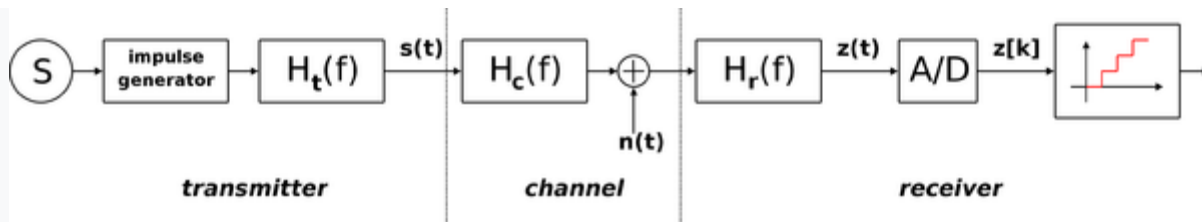

ASK diagram

ASK system can be divided into three blocks. The first one represents the transmitter, the second one is a linear model of the effects of the channel, the third one shows the structure of the receiver. The following notation is used:

- $h_t(f)$  is the carrier signal for the transmission
- $h_c(f)$  is the impulse response of the channel
- $n(t)$  is the noise introduced by the channel
- $h_r(f)$  is the filter at the receiver
- $L$  is the number of levels that are used for transmission
- $T_s$  is the time between the generation of two symbols

Different symbols are represented with different voltages. If the maximum allowed value for the voltage is  $A$ , then all the possible values are in the range  $[-A, A]$  and they are given by: the difference between one voltage and the other is:

Considering the picture, the symbols  $v[n]$  are generated randomly by the source  $S$ , then the impulse generator creates impulses with an area of  $v[n]$ . These impulses are sent to the filter  $h_t$  to be sent through the channel. In other words, for each symbol a different carrier wave is sent with the relative amplitude. Out of the transmitter, the signal  $s(t)$  can be expressed in the form:

In the receiver, after the filtering through  $h_r(t)$  the signal is:

where  $*$  indicates the convolution between two signals. After the A/D conversion the signal  $z[k]$  can be expressed in the form:

In this relationship, the second term represents the symbol to be extracted. The others are unwanted: the first one is the effect of noise, the third one is due to the inter symbol interference. If the filters are chosen so that  $g(t)$  will satisfy the Nyquist ISI criterion, then there will be no intersymbol interference and the value of the sum will be zero, so: the transmission will be affected only by noise.

## **2.Explain operation of spread spectrum modulation technique(DSSS) with neat block diagram? [2015]**

In **telecommunications**, direct-sequence spread spectrum (DSSS) is a **spread spectrum modulation** technique used to reduce overall signal **interference**. The spreading of this signal makes the resulting **wideband** channel more **noisy**, allowing for greater resistance to unintentional and intentional interference.

A method of achieving the spreading of a given signal is provided by the modulation scheme. With DSSS, the message signal is used to modulate a bit sequence known as a **Pseudo Noise (PN)** code; this PN code consists of a radio pulse that is much shorter in duration (larger bandwidth) than the original message signal. This modulation of the message signal scrambles and spreads the pieces of data, and thereby resulting in a bandwidth size nearly identical to that of the PN sequence.<sup>[1]</sup> In this context, the duration of the radio pulse for the PN code is referred to as the **chip** duration. The smaller this duration, the larger the bandwidth of the resulting DSSS signal; more bandwidth multiplexed to the message signal results in better resistance against interference.<sup>[1][2]</sup>

# Direct Sequence Spread Spectrum Using BPSK Example

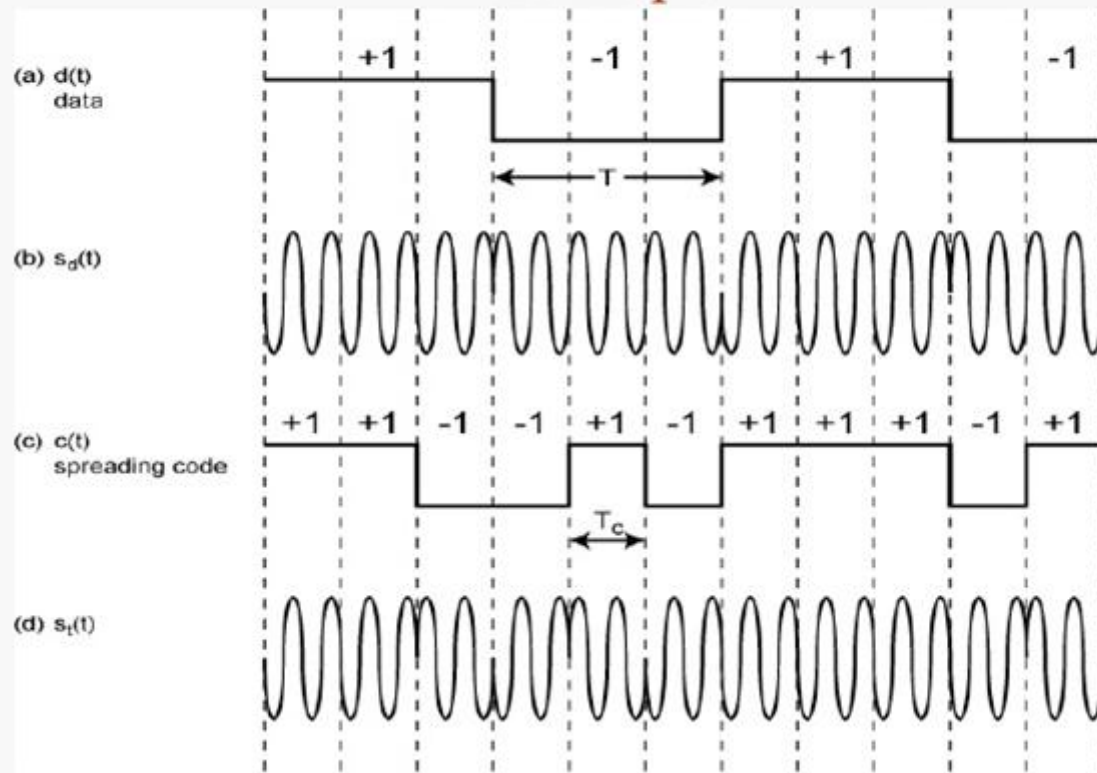

Some practical and effective uses of DSSS include the [Code Division Multiple Access \(CDMA\) channel access method](#) and the [IEEE 802.11b specification](#) used in [Wi-Fi networks](#).

