

## ELECTRONICS MEASUREMENT & INSTRUMENTATION (Theory-4)

**Q-1-a) Define Static and dynamic characteristics of an Instrument.**

**Ans:-**

Static characteristics are those characteristics of an instrument which do not vary with time and are generally considered to check if the given instrument is fit to be used for measurement.

The dynamic characteristics are those which change within a period of time that is generally very short in nature.

**Q-1-b) Discuss the operation of Moving Iron Instrument with a neat diagram.**

**Ans:-**

The most common ammeters and voltmeters for laboratory or switch board use at power frequencies are the moving iron instruments. The general principle of working of a moving iron instrument can be explained as –

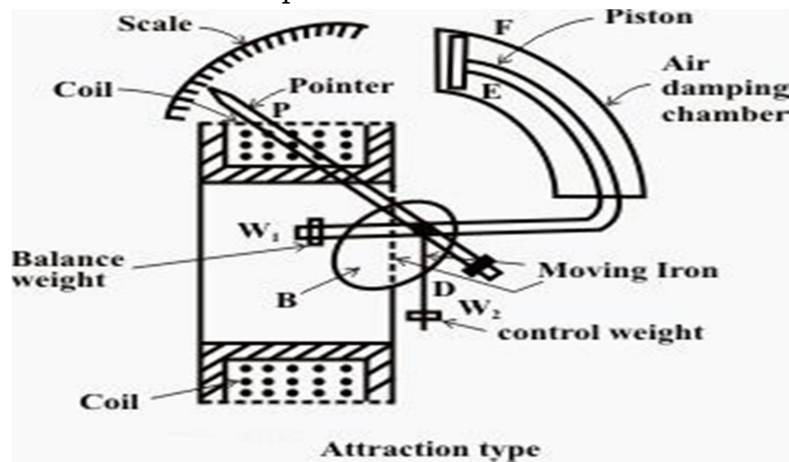

A plate or vane of soft iron or high permeability steel forms the moving element of the system. This iron vane is so situated that it can move in a magnetic field produced by stationary coil. The coil is excited by the current or voltage under measurement. When the coil is excited, it becomes an electromagnet and the iron vane moves in such a way so as to increase the flux of the electromagnet. This is because the vane tries to occupy the position of minimum reluctance. Thus the force produced is always in such direction so as to increase the inductance of the coil.

**Q-1-c) Discuss the construction and operation of series and shunt type ohm meter.**

**Ans:-**

**Series type ohm meter:-**

Series type of ohm meter consists of a basic d'Arsonval galvanometer movement connected in parallel with a shunting resistor  $R_2$ . This parallel circuit is in series with resistance  $R_1$  and a battery of emf  $E$ . The series circuit is connected to the terminals A and B of the unknown resistance  $R_x$ . Here,  $R_1$  = Current limiting resistor,  $R_2$  = Zero adjusting resistor,  $E$  = emf of internal battery and  $R_m$  = Internal resistance of the d'Arsonval movement.

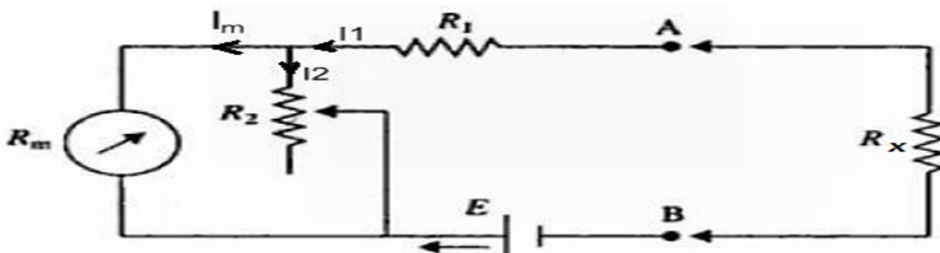

## ELECTRONICS MEASUREMENT & INSTRUMENTATION (Theory-4)

When  $R_x$  is '0' (terminal A & B shorted) maximum current flows through the meter. Under this condition resistor  $R_2$  is adjusted until the basic movement indicates full scale current  $I_{fs}$ . The full scale current position of the pointer is marked ' $0\Omega$ ' on the scale. Similarly, when  $R_x$  is removed from the ckt,  $R_x = \infty$  (terminal A & B opened), the current in the meter drops to zero and the movement indicates zero current which is marked ' $\infty$ '. Thus the meter will read infinite resistance at the zero current position and zero resistance at full scale current position. Hence, the meter has '0' at extreme right and ' $\infty$ ' at extreme left of the scale.

### **Shunt type ohm meter:-**

Shunt type of ohm meter consists of a battery in series with an adjustable resistor  $R_1$  and a PMMC ( $R_m$ ) meter movement. The unknown resistor  $R_x$  is connected across terminals A and B in parallel with the meter. An 'ON-OFF' switch S is provided to disconnect the battery from the ckt. when the instrument is not used. Here,  $R_1$  = Adjustable resistor,  $R_x$  = Unknown resistor, A & B = Terminals.

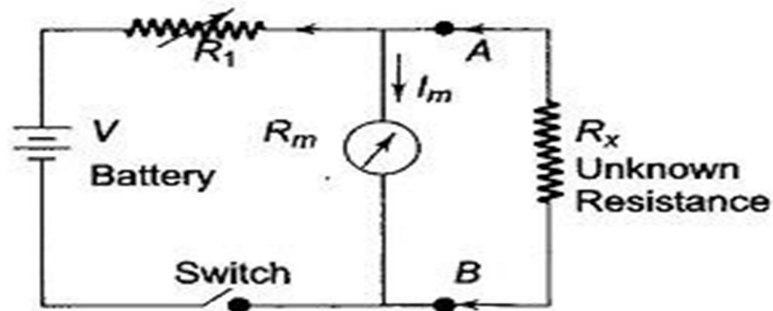

When  $R_x = 0$  (A and B terminals shorted), the ammeter current is zero. If  $R_x$  is  $\infty$  (A and B opened), the current through the meter and selecting a proper value of  $R_1$ , the pointer can be made to read full scale.

### **Q-2-a) Define the Resolution and Sensitivity of Digital Meters.**

**Ans:-**

Resolution is defined as the number digit positions or simply the number of digits used in the meter. Resolution is given by:  $R = 1/10^n$

Sensitivity is the smallest change in input which a digital meter is able to detect. Thus is the full scale value of the lowest voltage range multiplied by the resolution of the meter. It is given by:  $S = (f_s)_{\min} \times R$

### **Q-2-b) Explain the principle of operation of working of Digital Frequency meter with neat diagram.**

**Ans:-**

The signal whose frequency is to be measured is converted into a train of pulses, one pulse for each cycle of the signal. Then the numbers of pulses appearing in a definite time interval is counted by means of an electronic counter which is the direct indication of frequency of the unknown signal.

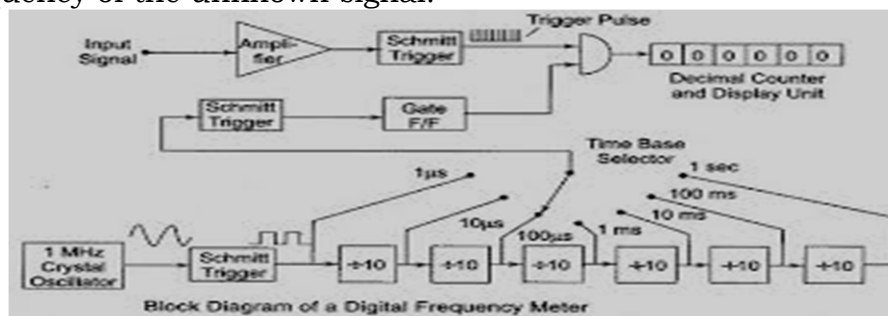

## ELECTRONICS MEASUREMENT & INSTRUMENTATION (Theory-4)

The i/p signal is amplified and is applied to schmitt trigger where it is converted to a train of pulses separated by the period of the original i/p signal. The oscillation frequency is 1MHz. Therefore, the time base o/p is shaped by a schmitt trigger into positive pulses, 1μs apart. The pulses are applied to 6-decade divider assemblies (DDAs).

A selector switch allows the time interval to be selected from 1μs to 1sec. The first o/p pulse from the time base selector switch passes through the schmitt trigger to the gate control flip-flop. The gate control flip-flop assumes a state such that an enable signal is applied to the main gate. The main gate being an AND gate, the i/p signal pulses are allowed to enter the decade counting assembly (DCAs) where they are totaled and displayed. This process continues till a second pulse arrives at the control gate flip-flop from the DDAs. The control gate reverses its state which removes the enabling signal from the main gate and no more pulses are allowed to get to counting assemblies since the main gate closes. Thus, the number of pulses which have passed during a specific time are counted and displayed on the DCAs. The frequency can be read directly in Hz, KHz or MHz in case the time base selector moves the decimal point in the display area.

**Q-2-c) Explain the principle of operation of working of Digital Tachometer. State its use.**

**Ans:-**

A digital tachometer is a digital device which measures the speed of a rotating object. In this meter we just take no. of pulses for one minute then divided by 60. The technique employed in measuring the speed of a rotating shaft is similar to the technique used in a conventional frequency counter, except that the selection of the gate period is in accordance with the rpm calibration. The no. of pulses of clock signal which are counted by a counter and divided by the open gate time (60/P) gives frequency of the rotating object.

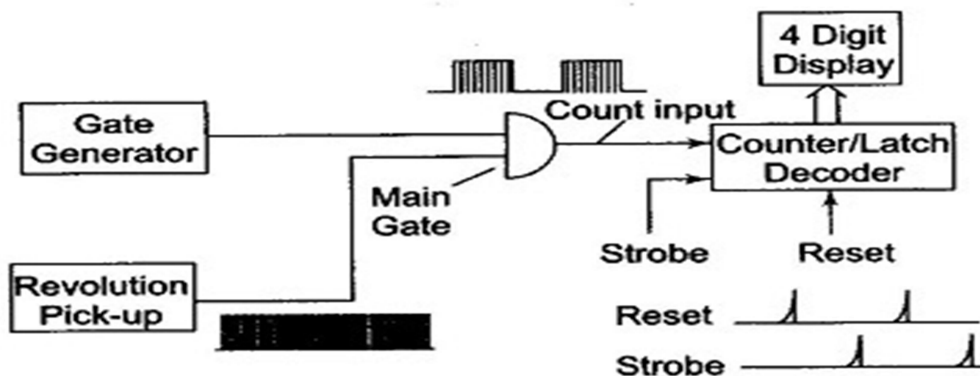

**Block Diagram of a Digital Tachometer**

Let assume, that rpm of a rotating shaft is R. Let P be the no. of pulses produced by the pickup for one revolution of the shaft. Therefore, in one minute the no. of pulses from the pickup is  $R \times P$ . Then the frequency of the signal from the pickup is  $(R \times P) / 60$ . Now if the gate period is  $G_s$  the pulses counted are  $(G_s \times R \times P) / 60$ .

In order to get the direct reading in rpm, the no. of pulses to be counted by the counter is R. So, we select the gate period as  $60/P$  and the counter counts –

$(R \times P \times 60) / 60P = R$  pulses and we can read the rpm of the rotating shaft directly.

## ELECTRONICS MEASUREMENT & INSTRUMENTATION (Theory-4)

**Q-3-a) What is Lissajous Pattern/Figure and what is its importance?**

**Ans:-**

Lissajous pattern/figure is the geometrical pattern obtained when two sine waves are applied simultaneously to the vertical and horizontal deflecting plates of CRO.

It is important in measuring the unknown frequency and phase angle of the signal applied to the CRO.

**Q-3-b) Discuss the block diagram of Dual Trace Oscilloscope.**

**Ans:-**

In a dual trace oscilloscope, the same electron beam is used to generate two traces which can be deflected from two independent vertical sources.

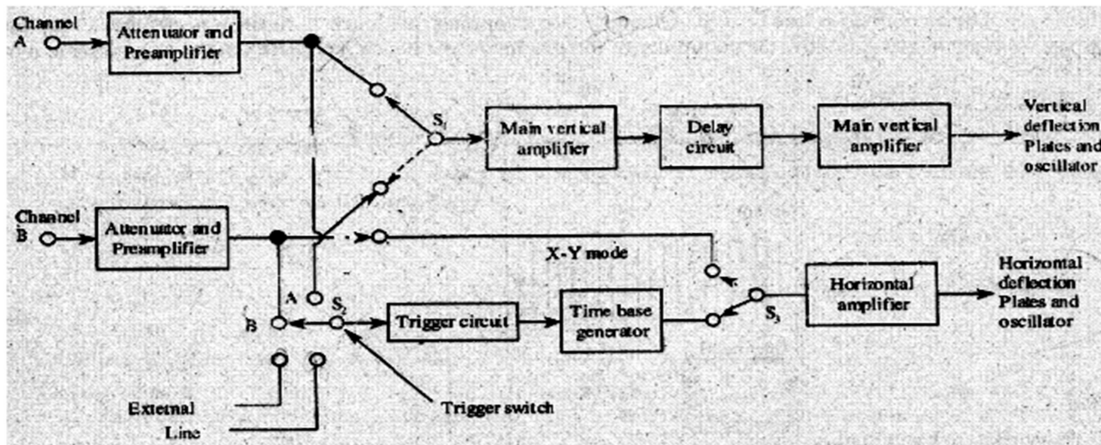

These oscilloscopes produce a dual-trace display by means of electronic switching of two separate input signals. There are two vertical input ckts. marked as channel A and B. Each separate vertical input channel are uses separate attenuators and preamplifier stages, so the amplitude of each signal can be independently controlled. Output of the preamplifiers is given to the electronic switch, which passes one signal at a time into the main vertical amplifier of the oscilloscope.

The time-base generator is similar to that of a single input CRO. By using switch S2 the ckt can be triggered on either A or B channel, waveforms or an external signal or online frequency. The horizontal amplifier can be fed from sweep generator or from channel B by switching S1. When switch S, is in channel B, its oscilloscope operates in the X-Y mode in which channel A acts as the vertical input signal and channel B as the horizontal input signal. There are two operating modes for the electronic switch –

- Alternate mode – In this mode the electronic switch alternates between channels A and B letting each through for one cycle of the horizontal sweep. The display is blanked during the flyback and hold-off periods, as the conventional oscilloscopes provides the sweep speed is much greater than the decay time of the CRT phosphor, the screen will show a steady display of both the waveforms at channels A and B. This mode can't be used for very low frequency signals.
- Chop mode – In this mode, the electronic switch free runs at a high frequency of the order of 100 KHz to 300 KHz. The result is that small segments from channels A and B are connected alternately to the vertical amplifier, and displayed on the screen. Provided the chopping rate is much faster than the horizontal sweep rate, the display will show a continuous line for each channel. If the sweep rate approaches the chopping rate then the individual segments will be visible and the alternate mode should now used.

## ELECTRONICS MEASUREMENT & INSTRUMENTATION (Theory-4)

**Q-3-c) Explain the operation of Digital Storage Oscilloscope with a neat block diagram. State its applications.**

**Ans:-**

The DSO is a superior method of trace storage. In this technique, the waveform to be stored is digitized, stored in a digital memory and retrieved for display on the storage oscilloscope.

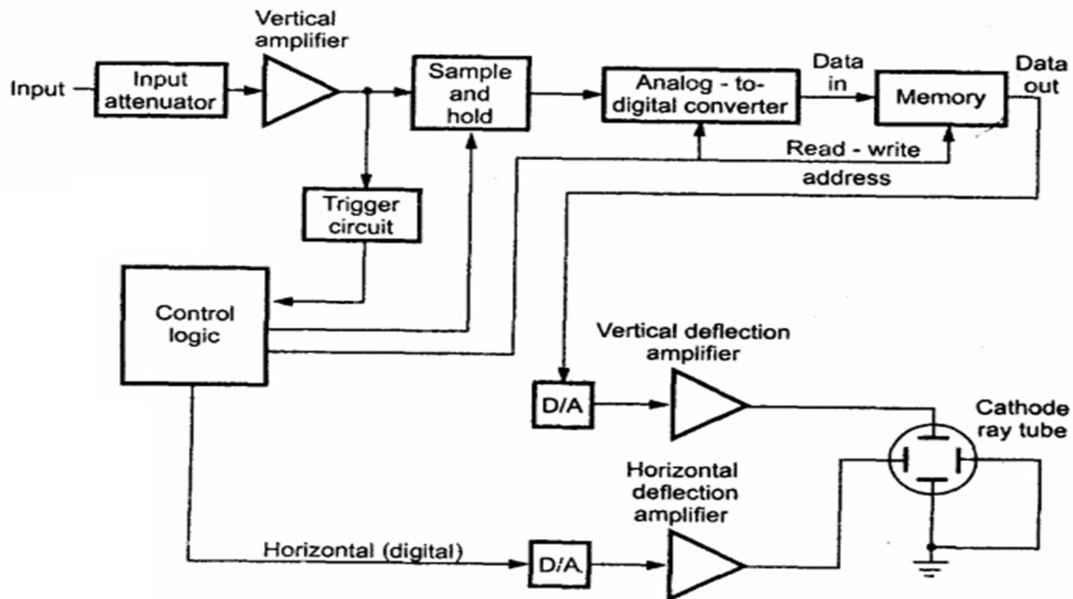

The i/p is amplified and attenuated with i/p amplifiers. The DSO uses both DAC and ADC for digitizing, storing and displaying analog waveforms. The overall operation is controlled and synchronized by the control ckt. The o/p of the input signal amplifiers feeds an ADC. The main requirement of the ADC is its speed, while accuracy and resolution are of secondary impedance. The digitized o/p is in the binary form and not BCD form. The successive approximation type of ADC is used in DSO.

Digitizing of the analog signals means to take samples of the i/p signal at periodic intervals of time. The sampling rate should be greater than twice the highest frequency present in the i/p signal. This ensures that aliasing effect will not occur and there is no loss of information. The size of memory is related to the amount of horizontal segments of the trace that can be divided into one sweep of the time base.

The selection of sampling rate and memory size depends on the type of waveform being recorded. As the analog signal is sampled at suitable rates, the data points are readable on the memory. Once the signal is stored, the required manipulation can be done. A continuous storage oscilloscope consists of a feature called pre trigger view. This indicates that the events that occurred before the trigger i/p signal was applied and displayed. This selection is a percentage selection. This mode is useful when failure occurs.

The DSO is used to give visual representation for a target of radar, to display cardiograms, to observe the radiation pattern generated by the transmitting antenna, etc.

## ELECTRONICS MEASUREMENT & INSTRUMENTATION (Theory-4)

**Q-4-a) State applications of oscilloscope.**

**Ans:-**

An oscilloscope is used to measure current, voltage, capacitance, inductance and to measure amplitude, frequency, phase angle of signal. Also it is used in radar, televisions, for engine pressure analysis, etc.

**Q-4-b) Explain the measurement of capacitance by Schering Bridge with the help of neat circuit diagram.**

**Ans:-**

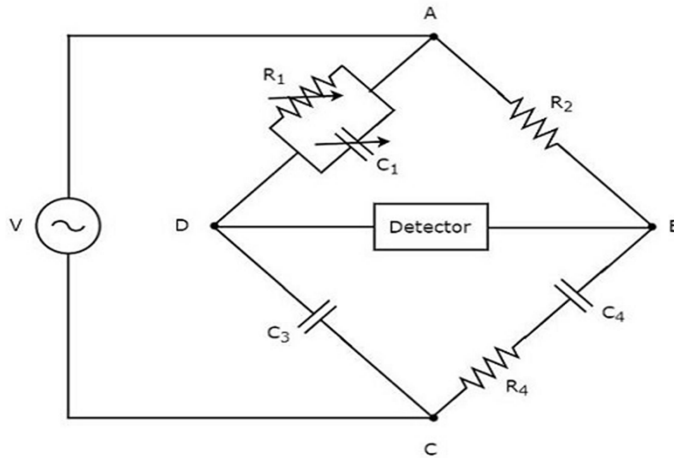

Schering Bridge is the most important AC bridge widely used to measure the unknown capacitors, dielectric loss and power factor.

The above figure shows the arrangement of this bridge. The capacitor C3 is a high quality mica capacitor (low loss) for general measurements or an air capacitor for insulation measurement.

Here, C<sub>4</sub> = Unknown capacitor and R<sub>4</sub> = Series resistance representing loss in C<sub>4</sub>  
 C<sub>3</sub> = Standard capacitor; R<sub>2</sub> = Non inductive resistance; C<sub>1</sub> = A variable capacitor  
 and R<sub>1</sub> = Variable non inductive resistance.

The general equation for bridge balance is –  $\bar{Z}_1 \cdot \bar{Z}_4 = \bar{Z}_2 \cdot \bar{Z}_3$

$$\text{Or } \bar{Z}_4 = \frac{\bar{Z}_2 \cdot \bar{Z}_3}{\bar{Z}_1} = \bar{Z}_2 \cdot \bar{Z}_3 \cdot \bar{Y}_1 \quad \text{----- eqn-1}$$

$$\text{Where, } \bar{Z}_4 = R_4 - \frac{j}{\omega C_4}, \bar{Z}_2 = R_2, \bar{Z}_3 = -\frac{j}{\omega C_3} \text{ and } \bar{Y}_1 = \frac{1}{R_1} + j\omega C_1$$

Substituting the values in eqn-1, we get –

$$R_4 - \frac{j}{\omega C_4} = R_2 \left(-\frac{j}{\omega C_3}\right) \left(\frac{1}{R_1} + j\omega C_1\right)$$

$$\text{Or } R_4 - \frac{j}{\omega C_4} = \frac{R_2(-j)}{R_1\omega C_3} + \frac{R_2 C_1}{C_3}$$

Equating the real and imaginary terms, we get –

$$\boxed{R_4 = \frac{R_2 C_1}{C_3}}$$

and

$$\boxed{C_4 = \frac{R_1 C_3}{R_2}}$$

## ELECTRONICS MEASUREMENT & INSTRUMENTATION (Theory-4)

**Q-4-c) Explain the working principle of Q-Meter with ckt. diagram.  
State use of Q-Meter.**

**Ans:-**

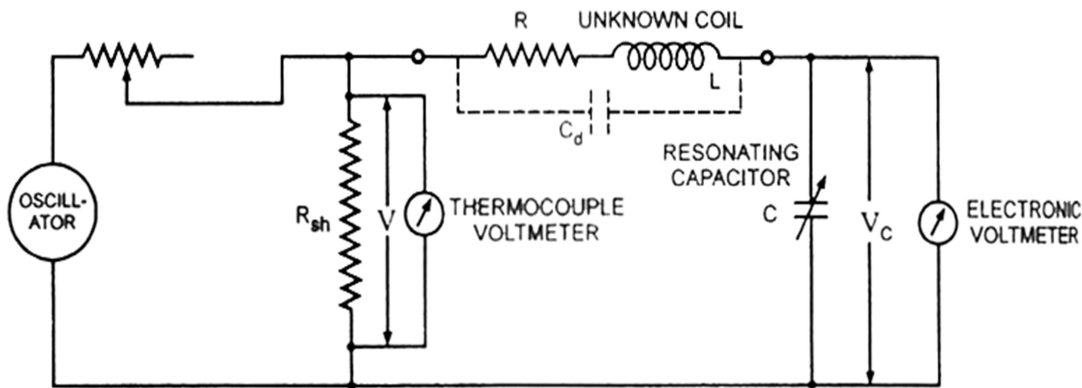

*Circuit Diagram of a Q-meter*

The ratio of the inductive reactance to the effective resistance of the coil is called quality factor or Q-factor of the coil. So,  $Q = X_L/R = \omega L/R$

The principle of the Q-meter is based on 'series resonance'(i.e) under resonant condition of an ac series ckt, voltage across the capacitor is equal to Q-times the applied voltage. If a fixed voltage is applied to the ckt, a voltmeter across the capacitor can be calibrated to read Q directly.

In this ckt, a wide range oscillator is used as power supply. The o/p of the oscillator is shorted by a low value resistance  $R_{sh}$  usually of the order of  $0.02 \Omega$ . The voltage across  $R_{sh}$  is measured by a thermocouple meter and the voltage across the capacitor  $V_c$  is measured with an electronic voltmeter.

For measurement, the unknown coil is connected to the test terminals of the instrument and the ckt is tuned to resonance either by varying the resonating capacitor C or the frequency of the oscillator. Reading of voltage across C &  $R_{sh}$  are obtained and the Q-factor of the coil is determined.

$$\text{At resonance: } X_L = X_C; V_L = IX_L; V_C = IX_C, V = IR,$$

Where,  $X_L$  = Inductive reactance,  $X_C$  = Capacitive reactance,  $R$  = Coil resistance,  $I$  = Ckt current,  $V_L$  = Inductive voltage &  $V_C$  = Capacitive voltage and  $V$  = applied voltage.

$$\text{Therefore, } Q = X_L/R = X_C/R = 1/\omega CR = IX_L/IR = V_C/V$$

The inductance of the coil can be calculated from known values of coil frequency and resonating capacitor C. At resonance,  $X_L = X_C$

$$\text{Or } 2\pi fL = \frac{1}{2\pi fC}$$

$$\text{Or } 4\pi^2 f^2 LC = 1$$

$$\text{Or } L = 1/(2\pi f)^2 C$$

## ELECTRONICS MEASUREMENT & INSTRUMENTATION (Theory-4)

### **Q-5-a) Define Strain Gauge.**

**Ans:-**

The Strain Gauge is a measurement transducer for measuring strain and associated stress in experimental stress analysis.

### **Q-5-b) Discuss the working principle of LCR Bridge and why this LCR Bridge is essential.**

**Ans:-**

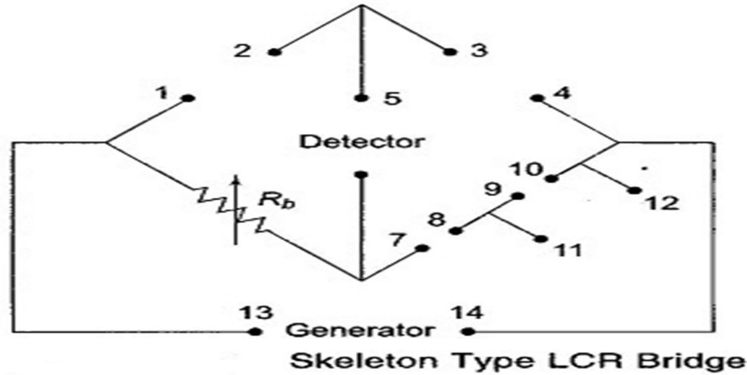

The LCR Bridge is also known as universal bridge. The impedance or RLC Bridge is employed for the measurement of resistance, inductance, capacitance, dissipation factor and quality factor.

This bridge consists of a signal source- dc for DC bridges and ac for AC bridges; bridges (Wheatstone's bridge for R, Maxwell's & Hey's bridge for L and Q, De Sauty's for C & D); imbalance amplifier and a metered detector in addition to power supply.

A sensitive center zero-micro-ammeter ( $25\mu\text{A} - 0.25\mu\text{A}$ ) is used to indicate the balance condition. In the skeleton type bridge,  $R_3$  is the decade resistance box. The other arms can be completed by connecting the unknown and standard component and a source of supply.

This bridge is used to measure-

- Resistance from  $100\text{m}\Omega - 10\text{M}\Omega$
- Inductance from  $1\mu\text{H}$  to  $100\text{H}$
- Capacitance from  $1\mu\text{F}$  to  $100\mu\text{F}$

This bridge can be used for both DC and AC measurement. For dc measurement a 1.5V to 1.75V battery is used.

### **Q-5-c) Explain the working principle of LVDT with a neat diagram. State its use.**

**Ans:-**

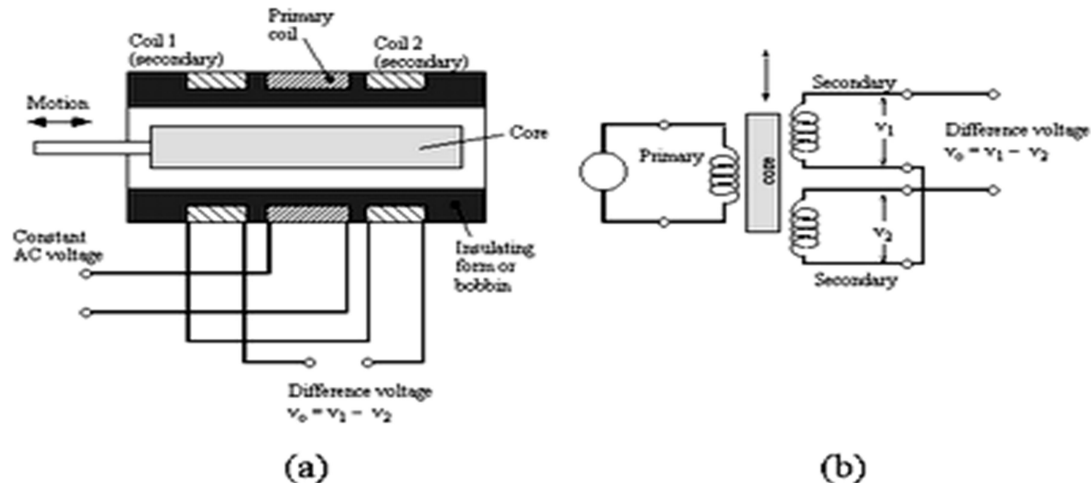

The most widely used inductive transducer to translate the linear motion into electrical signals is the linear variable differential transformer (LVDT).



## ELECTRONICS MEASUREMENT & INSTRUMENTATION (Theory-4)

The transformer consists of a single primary winding P and two secondary windings S1 and S2 wound on a cylindrical former. The secondary windings have equal number of turns and are placed identically on either side of the primary. The primary winding is connected to an AC source. A movable soft iron core is placed inside the former. The displacement to be measured is applied to the arm attached to the soft iron core.

Since primary winding is excited by an AC source, it produces an alternating magnetic field which in turn induces AC voltages in the two secondary windings.

**Q-6-a) Define resistive Transducer and name different types.**

**Ans:-**

The transducer whose resistance varies because of the environmental effects such type of transducer is known as the resistive transducer. The change in resistance is measured by the ac or dc measuring devices. The resistive transducer is used for measuring the physical quantities like temperature, displacement, vibration etc. *Types of resistive transducers are -* Wire resistance strain gauge, Thermistors, Thermocouples, Light Dependent Resistors (LDRs), Electronic thermometers and Potentiometer, etc.

**Q-6-b) Explain the construction and working of optical pyrometer with a neat circuit diagram.**

**Ans:-**

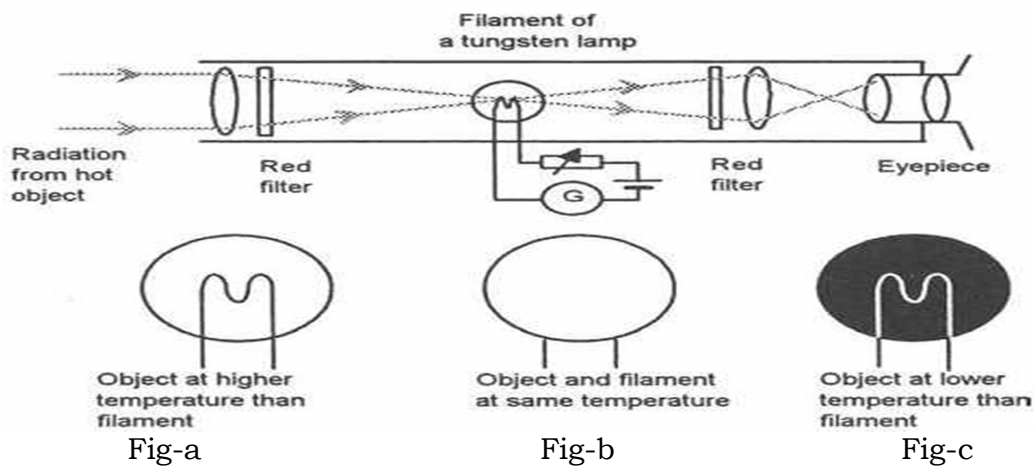

In an optical pyrometer, the wavelength of radiation accepted is restricted by means of a color filter and brightness is measured by comparison with a standard lamp. An image of the radiating source is produced by a lens and made to coincide with the filament of an electric lamp.

The current through the lamp filament is made variable so that the lamp intensity can be adjusted. The filament is viewed through an eye piece and filters. The current through the filament is adjusted until the filament and the images are of equal brightness. When brightness of image produced by the source and brightness produced by the filament are equal, the outline of the filament disappears as shown in fig-a.

However, if the temperature of the filament is higher than the required for equality of brightness, filament becomes too bright as shown in fig-b. On the other hand, if the temperature of filament is lower, the filament becomes dark. Since, the intensity of light of any wavelength depends upon the temperature of the radiating body and the temperature of filament depends upon the current flowing through the lamp. The instrument may be directly calibrated in terms of the filament current. However, the filament current depends upon the resistance of the filament, modern pyrometers are calibrated in terms of resistance directly.

## ELECTRONICS MEASUREMENT & INSTRUMENTATION (Theory-4)

**Q-6-c) Explain the working and operation of Proximity and Light sensors with a neat diagram.**

**Ans:-**

A proximity sensor consists of an element that changes either its state or an analog signal when it is close to, but often not actually touching, an object.

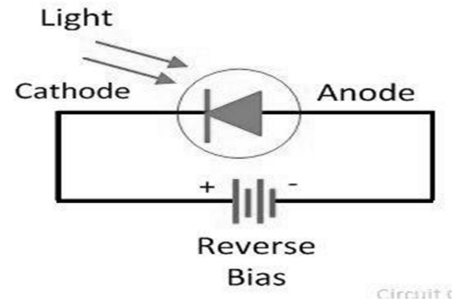
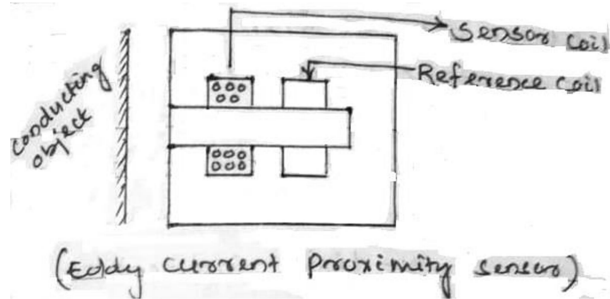

When a coil is supplied with an alternating current an alternating magnetic field is produced. If there is a metal object in close proximity to this attending magnetic field, then eddy currents are induced in it. The eddy currents themselves produce a magnetic field which distorts the magnetic field responsible for their production. Consequently, the impedance of the coil changes and so the amplitude of the alternating current. This change at some preset level, can be used to trigger a switch.

Photodiodes are semiconductor junction diodes which are connected into a circuit in reverse bias, so giving a very high resistance. So that when light falls on the junction the diode resistance drops and the current in the circuit rises appreciably.

**Q-7-a) Define the principle of Load Cell.**

**Ans:-**

Load Cells are elastic devices that can be used for measurement of force through indirect methods(i.e) through use of secondary transducers. It utilizes an elastic member as the primary transducer and strain gauges as secondary transducer. When the combination of the strain gauge-elastic member is used for weighing, is called Load Cell.

**Q-7-b) Explain the working principle of a Function Generator with a neat block diagram.**

**Ans:-**

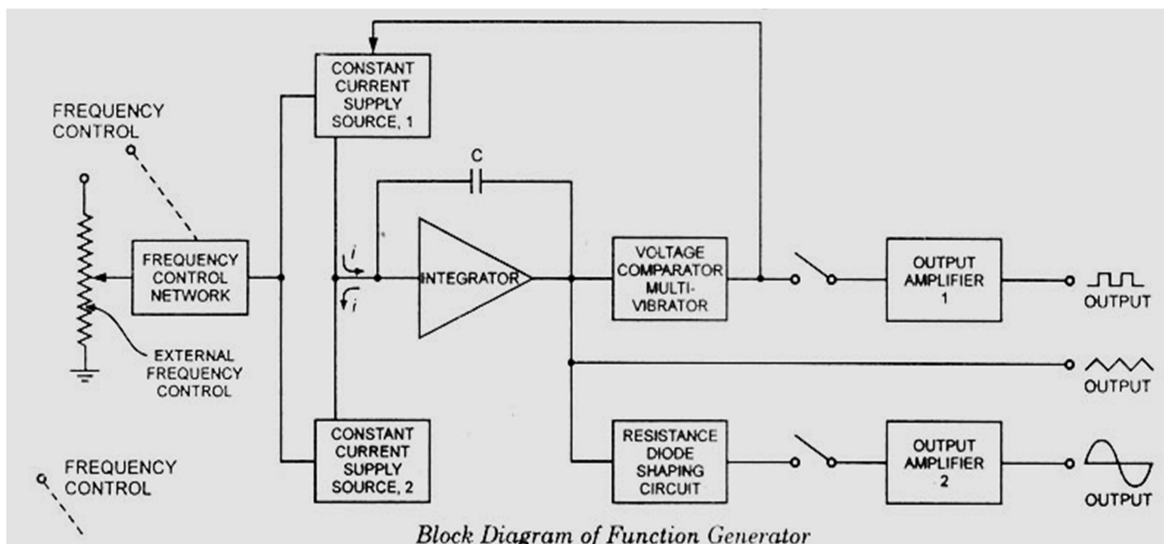

A function generator is an instrument that has the capability of producing different types of waveform as its output signal. The above figure shows the block dgm.

## ELECTRONICS MEASUREMENT & INSTRUMENTATION (Theory-4)

In this generator the frequency is controlled by varying the magnitude of current that drives the integrator. The frequency controlled voltage regulates two current supply sources. The upper current supply source supplies constant current to the integrator whose voltage rises linearly with time according to output signal equation- $V_{out} = -\frac{1}{C} \int_0^t i dt$ . An increase or decrease in the current increases or decreases the slope of the output voltage and thus controls the frequency.

The voltage comparator multivibrator changes state at a predetermined maximum level of the integrator output voltage. This change cuts off the current supply from the upper supply source and switches to the lower supply source. The lower supply source supplies a reverse current to the integrator so that its output drops linearly with time. When the output attains a predetermined level, the voltage comparator again changes state and switch 'ON' to upper supply source.

The output of the integrator is a triangular wave whose frequency depends on the upper constant current source. The voltage comparator delivers square wave output voltage of the same frequency as that of input triangular waveform. The triangular wave is synthesized into sine wave using diode resistance network. In this shaper circuit, the slope of triangular wave is changed as its amplitude changes; this results in a sine wave with less than 1% distortion.

**Q-7-c) Explain the measurement of Self Inductance by Maxwell's Bridge with neat diagram.**

❖ Ans:-

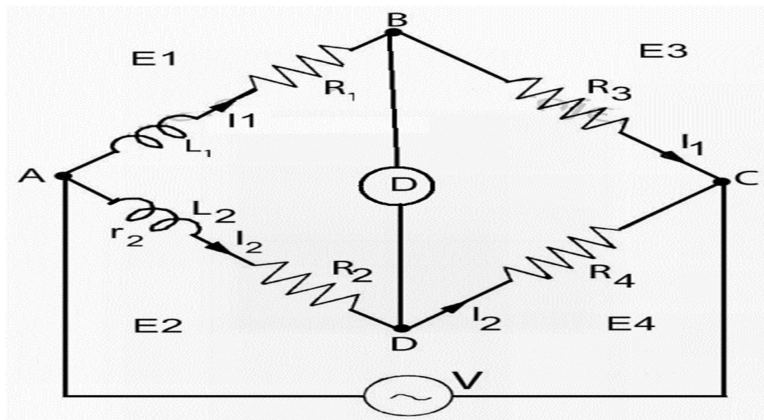

This bridge circuit measures an inductance by comparison with a variable standard self-inductance.

Here,  $L_1$  = Unknown inductance of resistance  $R_1$

$L_2$  = Variable inductance of fixed resistance  $r_2$

$R_2$  = Variable resistance connected in series with inductor  $L_2$

and  $R_3$  &  $R_4$  = Known non inductive resistances

According to bridge balance condition, at balance –

$$L_1 = \left(\frac{R_3}{R_4}\right) \times L_2$$

and  $R_1 = \left(\frac{R_3}{R_4}\right) \times (R_2 + r_2)$

\*\*\*\*\*