

PNS SCHOOL OF ENGG & TECH MARSHAGHAI



LECTURE NOTES ON
AUTOMOBILE ENGINEERING
6TH SEM MECHANICAL

PREPARED BY
SUBARNA KESHARI SINGH
DEPARTMENT OF MECHANICAL ENGINEERING

1.0 INTRODUCTION AND TRANSMISSION SYSTEM

1.1

Automobile:-

“Auto” means self and “mobile” means movable. Thus a self-moving vehicle is known as “automobile”. The term is generally used for motor cars, delivery vans, trucks etc.

Definition:-

It is a self-propelled vehicle which is used for the transportation of goods and passengers (on the ground).

Necessity:-

Automobiles are an important part of life in today's world. It is a basic need for every household. Imagine walking hundreds of miles for days to get from one place to another, but because of the discovery of automobiles, transportation today is much faster, easier and reliable.

Classification:-

*Purpose:- > goods

E.g- truck, dump truck, lorry

> Passengers

E.g- car, bus, motorcycle

*Capacity of vehicle:- > light duty

> heavy duty

*On the basis of fuel used:- > petrol

> Diesel

> Electric

> Gas and solar

*No. Of wheels used:- > 2-wheeler

> 3-wheeler

- > 4-wheeler
- > 10-wheeler etc.

*On the basis of construction:-

- > saloon cars
- > bus
- > trucks, half and full body, folding or detachable
- > pick up vans
- > station wagon
- > Matador vans
- > Vanity vans
- > Jeep
- > dumper

MAIN UNITS of a motor-car

(a) Body: Where passengers sit or luggage is kept. (b) Chassis: This unit which is used as a base for engine-parts and other parts of motor car.

(c) Engine: This unit is also known as power unit. It includes fuel pump, carburettor, self, dynamo, distributor, spark plug, lubrication pump, etc.

(d) Running Gear: This unit consists of those parts which give motion to the vehicle such as front and rear axles, wheels, springs, frame, brake, steering etc.

(e) Transmission System: Those parts of the motor-car which transmit the engine power to its wheels, such as clutch, gear box, universal joint, propeller shaft, differential and axle shaft etc. are

included in the transmission system. Variations of speed ratios and forward and reverse motion are obtained through the transmission system.

Functions of a Car (Main Assembly)

- Motion
- Stopping of Motion
- Changing direction of Motion
- Comfort of the Passenger
- Music and air-conditioning system
- Protection of the Passengers and goods from external environmental factors

→ (Sub Assembly)

- Engine
- Transmission System
- Braking System
- Steering System
- Suspension System
- Electrical System
- Safety System

LAYOUT OF Automobile chassis

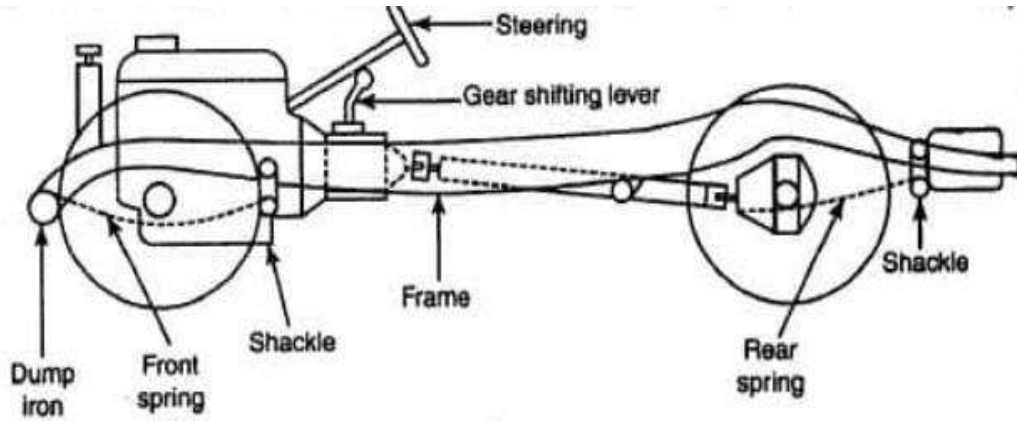

Front view (Elevation)

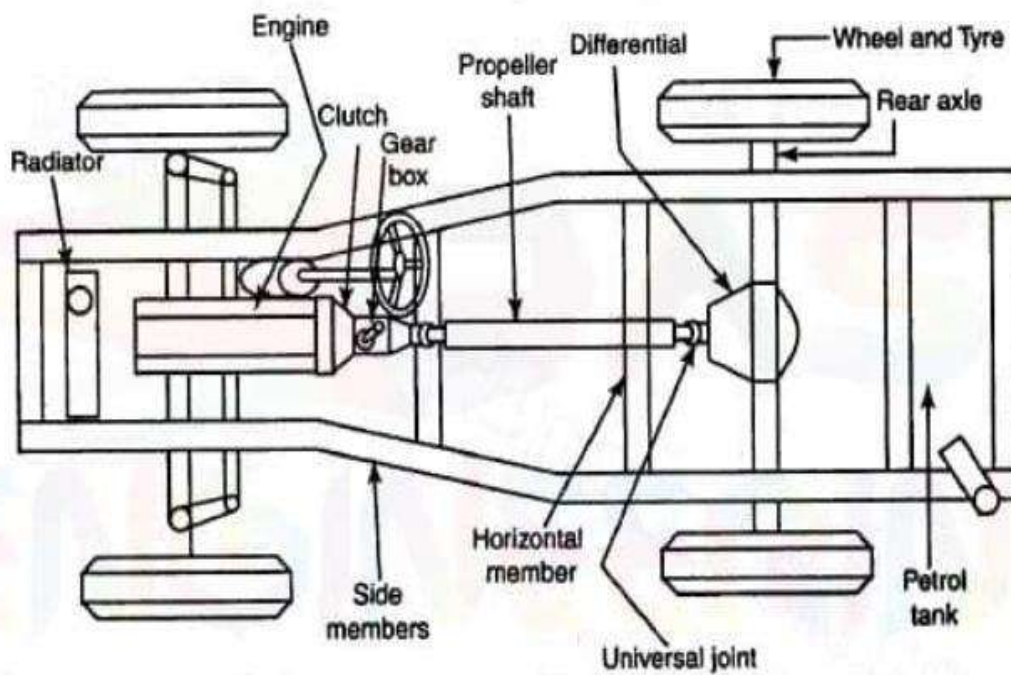

Top view (Plan)

INTRODUCTION TO TRANSMISSION System

The transmission system is the system utilizing which power developed by the engine is transmitted to road wheels to propel the vehicle. In automobiles, the power is developed by the engine which is used to turn wheels. Therefore, the engine is to be connected to the transmission systems for transmitting power to wheels. Also, there should be a system utilizing which engine could be engaged and disengaged with the transmission system smoothly and without shock so that the vehicle mechanism is not damaged and passengers do not feel inconvenience. A clutch is employed in automobiles for this purpose.

> The engines employed in automobiles are of very high speed. Hence, a speed reduction is necessary to reduce the speed to moderate level as well as to get the required high torque while moving from rest. For this purpose, a gearbox is employed in automobiles.

> The figure shows the general arrangement of a power transmission system of an automobile.

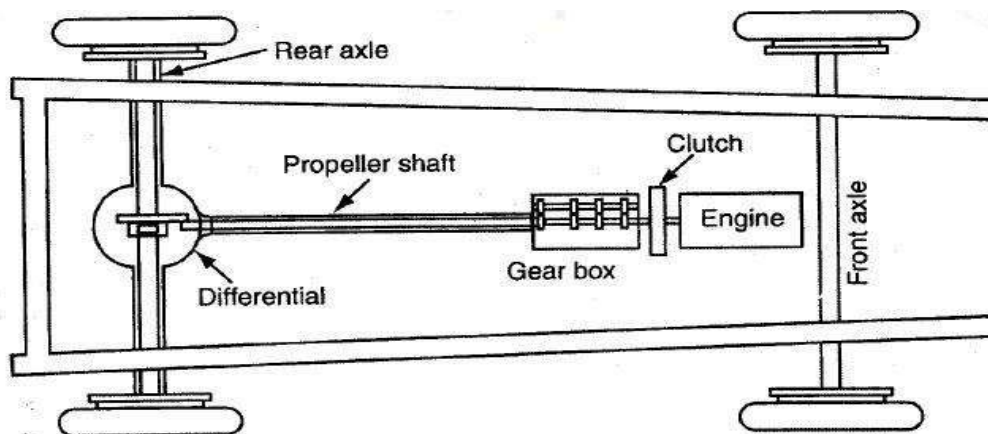

General arrangement of power transmission

- > The motion of the crankshaft is transmitted to the gearbox through the clutch. The gearbox consists of a set of gears to change the speed according to the requirement. The motion is then transmitted to the propeller shaft from the gearbox through a universal joint. The purpose of the universal joint is to connect two shafts at an angle for power transmission.
- > The power is transmitted to the differential unit through another universal joint. Finally, the power is transmitted from the differential to wheels through the rear end. The differential unit is used to provide the relative motion between two-run wheels while the vehicle is taking a turn

1.2

CLUTCH System

A Clutch is a mechanism used to connect or disconnect the engine from the rest of the transmission elements. It is located between the engine and gearbox.

During normal running and stationary position, it is always in the engaged condition. The clutch is disengaged when the driver processes the clutch pedal. The clutch is disengaged for starting, changing gears, stopping and idling.

When the clutch is engaged, the engine will be connected to the transmission, and power flows from engine to rear wheels through a transmission system.

When 'the clutch is disengaged by pressing the clutch pedal, the engine will be disengaged from the transmission. Thus, the power does not flow to rear wheels while the engine is still running

Principles of Operation of Friction Clutch

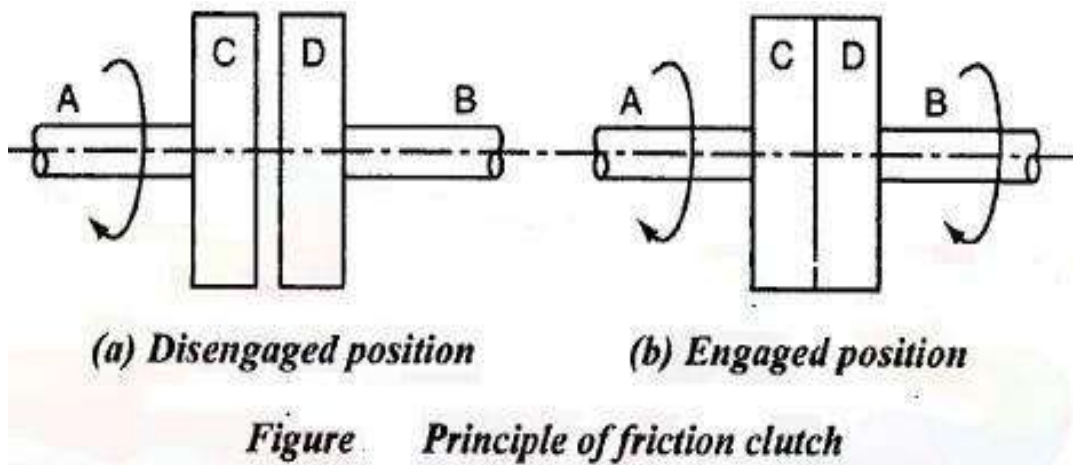

Principle of friction clutch

The clutch works on the principle of friction. In Figure, the driving shaft A with flange C is rotating at 'N' rpm, and shaft B with the flange D is keyed to the driven shaft which is in stationary position when the clutch is not engaged.

Now, an external force is applied to the flange D so that it comes in contact with flange C.

As soon as the contact is made, they are united due to friction between them and the flange D starts rotating with flange C. The rotational speed of flange D depends on the friction between surfaces C and D which in turn is proportional to the external force applied.

Functions of a Clutch:

The torque developed by the engine at the starting speed is very low. Therefore, it is not possible to start the engine under load. This requires that the transmission system should provide a means of connecting and disconnecting the engine from the rest of the transmission system. Such an operation must be smooth and without shock to the occupants of the vehicle.

Thus the two main functions of a clutch are:

1. To engage and disengage the transmission from engine to the remaining parts of the transmission. (To allow the engine to be separated from rest of the transmission system) This is required when:

(a) Starting and running the engine at a sufficiently high speed to generate sufficient power necessary for moving the vehicle from rest.

(b) Shifting the gears so that damage to gear teeth can be avoided. (c) Stopping the vehicle after applying brakes.

2. The second function of the clutch is to allow the engine to take up the driving load of the vehicle gradually and without shock.

Requirements of clutch:

The main requirements of a clutch are as follows:

It should be able to transmit the maximum torque of the engine.

It should engage gradually to avoid sudden jerks.

It should be able to dissipate a large amount of heat generated during clutch operation.

It should be dynamically balanced, particularly in the case of high-speed engine clutches.

It should have a suitable mechanism to damp vibrations and to eliminate noise produced during power transmission.

It should be as small as possible so that it will occupy minimum space.

It should be easy to operate requiring as little exertion as possible on the part of the driver.

It should be made as light as possible so that it will continue to rotate for any length of time after the clutch has been disengaged.

It must be trouble-free and have longer life.

It must be easy to inspect, adjust, and repair

Clutch Friction Lining material and their Necessity :

The materials for clutch lining are:

1. Leather
2. Cork
3. Fabric
4. Asbestos
5. Raybestos and Ferodo
6. Non- asbestos clutch lining material.

Necessity of clutch lining:

1. To transmit maximum power from engine flywheel transmission without jerk
2. To dissipate the heat and able to withstand higher heat generated
3. It should have a higher coefficient of friction
4. It should be cheap and easy to manufacture.

Main parts of Clutch :

It consists of-

(a) a driving member,

.The driving members consists of a flywheel which is mounted on the engine crankshaft

.The flywheel is bolted to a cover which carries pressure plate, pressure springs, and release levers.

.As the flywheel is bolted to the cover assembly, thus, the entire assembly of the flywheel and the cover rotate all the time.

.The clutch housing and cover provided with openings so that the heat produced during the function dissipates easily

(b) a driven member, and

.The driven members consist of a disc or plate called a clutch plate.

.The clutch is free to slide on the splines of the clutch shaft.

.It carries friction materials on both of its surfaces.

.When the clutch plate is gripped between the flywheel and the pressure plate, it rotates the clutch shaft through splines.

(c) an operating member.

Parts Of Clutch



The operating member consists of a pedal or lever which can be pressed to disengage the driving and driven plate.

Types Of Clutch :

Some types of clutches used in vehicles are given below :

The classification of clutch

1) Positive clutch

Dog clutch or spline clutch (In and Out clutch)

2) Gradual engagement Clutch

a) Electromagnetic clutch

b) Vacuum operated clutch

c) Hydraulic clutch

d) Fluid clutch or Fluid flywheel clutch

e) Friction clutch

i) Cone clutch (Internal and External)

ii) Disc Plate clutch (Single plate and Multi-Plate)

iii) Semi centrifugal clutch

iv) Diaphragm or conical spring clutch (Taper finger and crown spring)

v) Centrifugal clutch

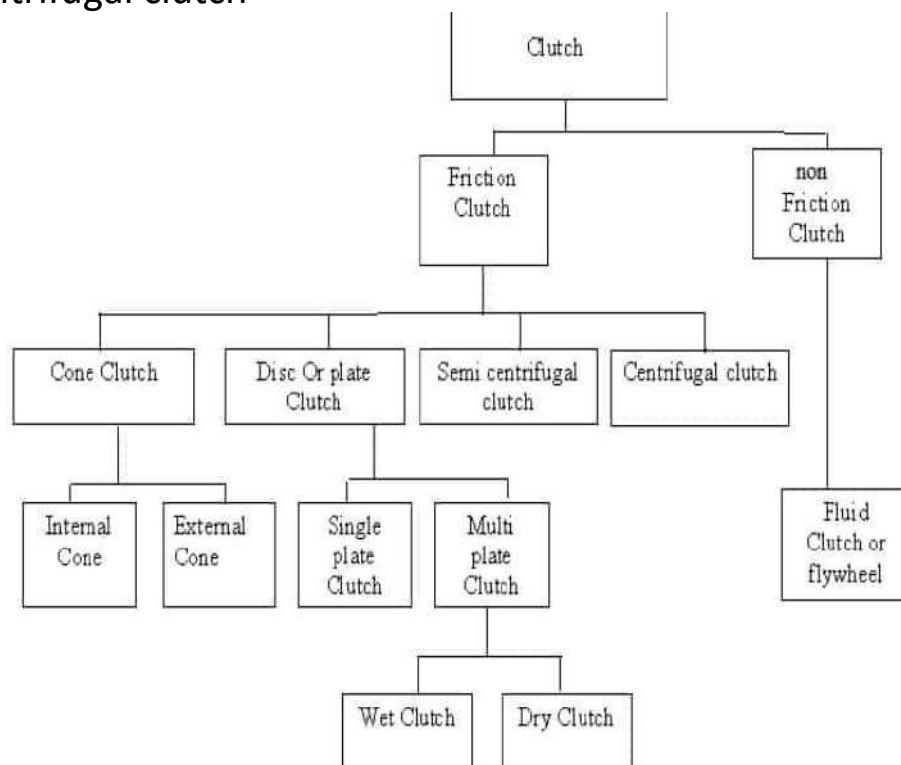

Multi-Plate (Dry) Clutch:

It is the extension of a single plate clutch. It consists of several clutch (friction) as well as pressure plates. As the number of plates increased, the friction surfaces also increase. The increase in the number of friction surfaces increases the capacity of the clutch to transmit torque. The plates are alternately fitted to the engine shaft and gearbox shaft. They are firmly pressed by strong coil springs and assembled in a cover assembly. Each alternate plate has inner and outer splines, this each of the alternate plate slides on the splines on the pressure plate.

Multi plate (dry) clutch

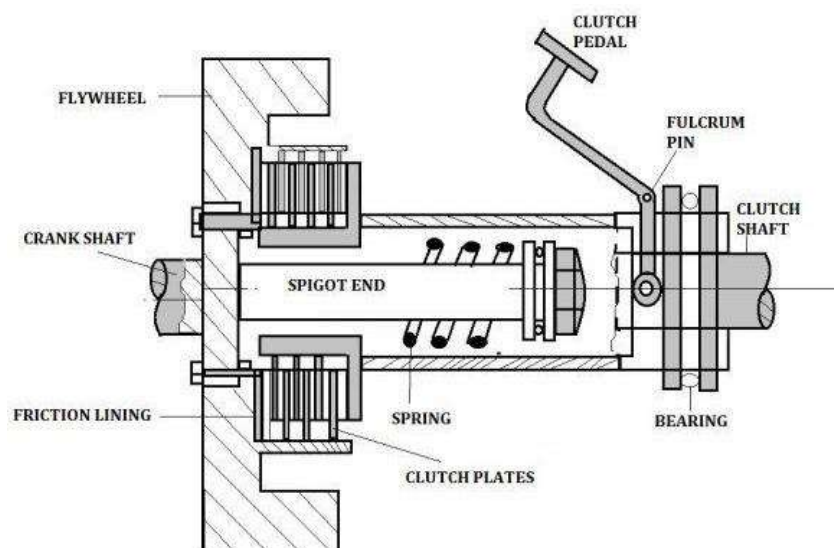

FIG: MULTI PLATE CLUTCH

Working of Multi-Plate Clutch:

The pressure plates are used to apply the pressure on friction plates and the inside diameter of the pressure plate is splined while making the inside diameter splined, the rotating motion of the pressure plate is restricted. The pressure plate moves on the driven shaft axially. When we apply the pedal the pressure

plates and the friction plates come in contact with each other and the speed or power is transmitted from the engine shaft to the transmission shaft.

Applications Of Multi-Plate Clutch :

This type of clutch is used in Scooters and Motor Cycles, where space availability is limited. Besides, this finds the application in some Heavy Transport Vehicles and Racing Cars where high torque is to be transmitted.

Single plate Clutch :

A single disc or plate clutch as shown in the figure consists of a clutch plate whose sides are faced with the friction material (usually ferrodo). It is mounted on the hub which is free to move axially along the splines of the driven shaft. The pressure plate is mounted inside the clutch body which is bolted to the flywheel. Both the pressure plate and the flywheel rotate with the engine crankshaft or the driving shaft. The pressure plate pushes the clutch plate towards the flywheel by a set of strong spring which is arranged radially inside the body. The three levers (also known as release levers or fingers) are carried on the pivots suspended from the case of the body. These are arranged in such a manner so that the pressure plate moves away from the flywheel by the inward movement of a thrust bearing. The bearing is mounted upon the forked shaft and moves forward when the clutch pedal is pressed.

Necessity of Single plate clutch

1) To transmit a large amount of torque single plate clutch required

- 2) Response time to operate is very less compared to the multi-plate clutch.
- 3) It generates low heat so no need of cooling media required.
- 4) It should be dynamically balanced and easy to operate.

single plate clutch diagram

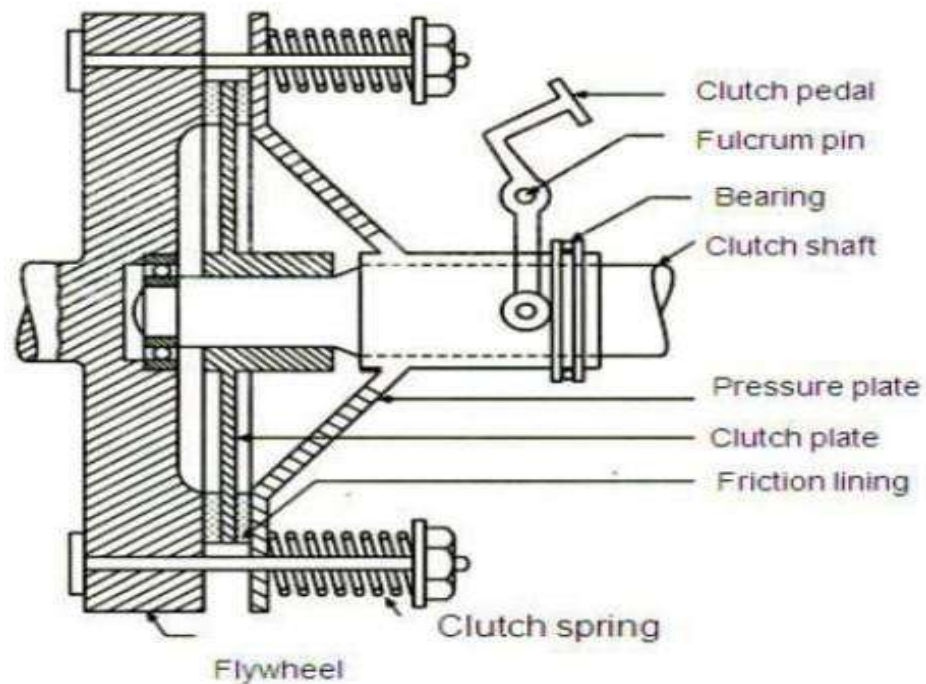

Figure: Single Plate Dry Clutch

1.3

Gearbox

The gearbox is a mechanical device used to increase the output torque or to change the speed (RPM) of a motor. The shaft of the motor is connected to one end of the gearbox and through the internal configuration of gears of a gearbox, provides a given output torque and speed determined by the gear ratio.

Introduction

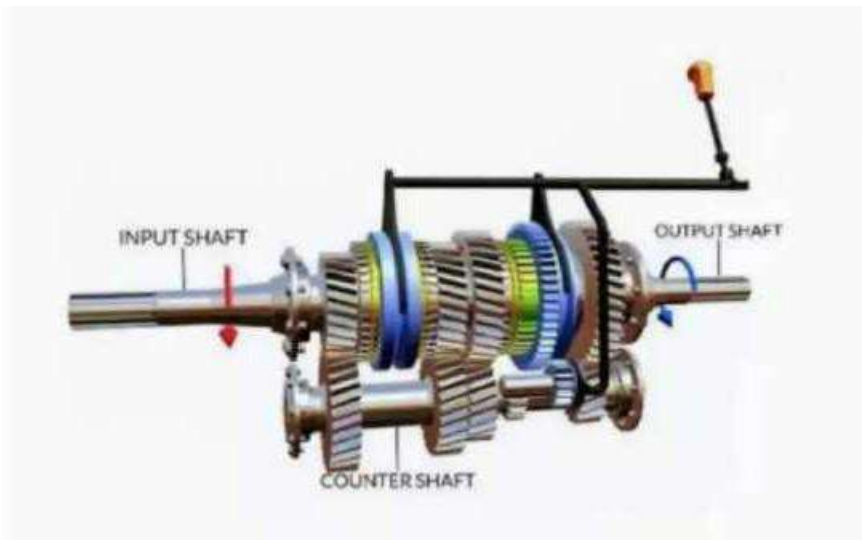

Gearbox Diagram

High torque is required to start the vehicle from rest, accelerating, hill climbing, pulling a load and facing other resistances. But the IC engine operates over a limited effective speed range which produces a comparatively low torque. In such a situation, the engine is responsible for the stall and the vehicle rests if the speed falls below the limit.

The torque developed by the engine is increasing within limits with the increase of engine speed and reaches a maximum value at some predominant speed. If the engine directly connects to the driving axle, the engine speed may reduce.

Due to the variable nature of the vehicle resistance resulting in load and gradient changes, it requires that the engine power should be available over a wide range of road speeds. Hence, for this reason, the engine speed is maintained by using a reduction gear resulting in the road wheels rotating at a proper speed suited to the operating conditions of the vehicle.

Therefore, a single torque multiplication in the rear axle must be interposed and a variable multiplication factor in the gearbox is provided for this purpose.

The Necessity Of Gearbox

To maintain engine speed on all conditions of load and vehicle speed, the gearbox uses a system to maintain engine speed, while sacrificing the same road speed. To enable the engine to run faster on-road wheels as well as to multiply the torque, a gearbox is required.

Parts Of Gearbox

The Parts Of Gearbox are as follows given below :

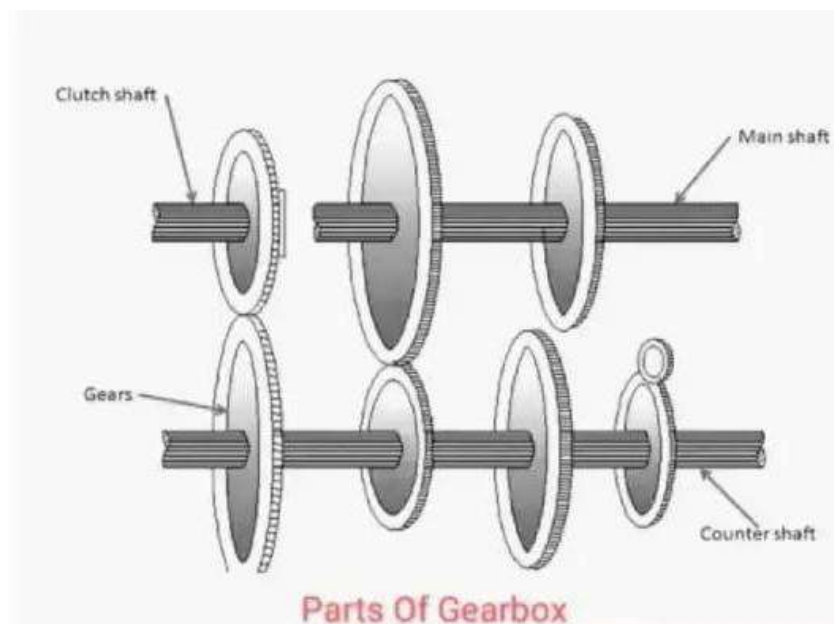

1. Clutch Shaft / Driving Shaft / Input Shaft

A clutch shaft is a shaft that takes power from the engine to supply another shaft. The clutch shaft or driving shaft is connected through the clutch and when the clutch is engaged, the driving shaft also rotates. Only one gear is fixed on the

clutch shaft and this engine rotates with the same speed as the crankshaft. In addition, the driving shaft and main shaft are in the same line.

2. Counter Shaft / Layshaft

The counter shaft is a shaft that connects directly to the clutch shaft. It has gear which connects it to the clutch shaft as well as the main shaft. It can be run at engine speed or below engine speed according to gear ratio.

3. Main Shaft / Output Shaft

The main shaft or output shaft that rotates at different speeds and also provides the necessary torque to the vehicle. The output shaft is a splined shaft, so that the gear or synchronizer can be moved to engage or disengage.

4. Bearings

The bearings are required to support the rotating part and reduce friction. The gear box has both a counter and main shaft which is supported by the bearing.

5. Gears

Gears are used to transmitting the power from one shaft to another shaft. The amount of torque transmitted through the gears depends on the number of teeth and the size of the gears. Higher the gear ratio, higher the torque / acceleration and lower the speed. All gears except those on the main shaft are fixed to their respective shafts; they can slide in any of the directions along the shaft.

6. Gear Selector Fork

Gear selectors are simple devices that use a lever that selects gears to engage in disengage mechanisms. The motion of the lever slides the engaging part on the shaft. It depends on the type of gearbox whether the lever slides the gear or synchronizer that are already forged along the main shaft.

Types Of Gearbox

➤ Manual Transmission

1. Sliding Mesh Gearbox

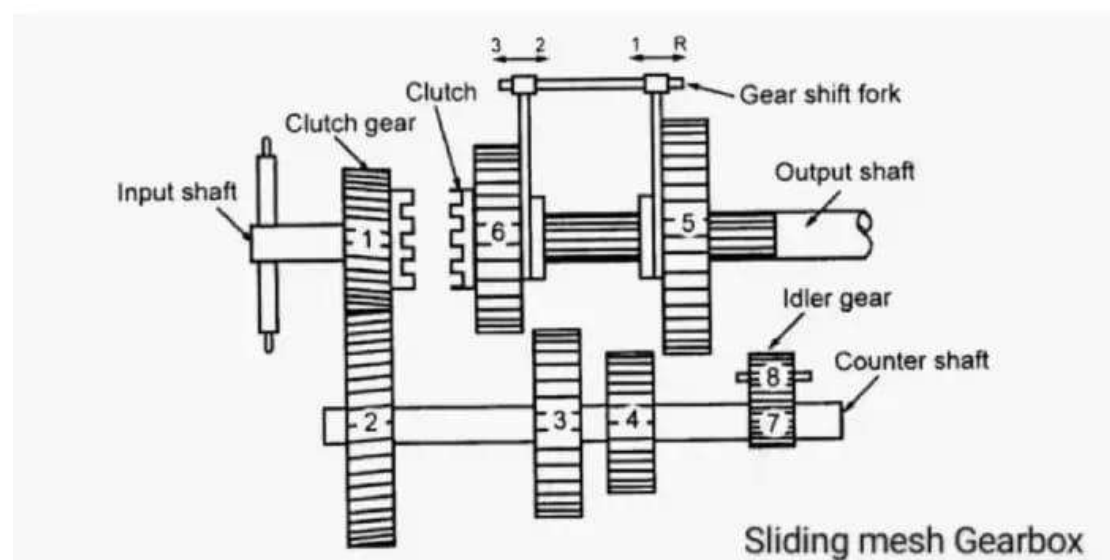

(I) Sliding Mesh Gearbox

It is the simplest type of gearbox. In this gearbox, spur gears are used. The Figure shows the construction of a sliding mesh type transmission having three forward and one reverse speeds.

There are three gears (1, 6 and 5) attached on the main shaft and four gears (2, 3, 4 and 7) on the layshaft.

The two gears on the main shaft (6 and 5) can be slid by a shafting yoke and mesh with the gears (3 and 4) on a layshaft.

Therefore, it is called a sliding mesh gearbox. A separate idler gear (8) is mounted on the idler shaft.

2. Constant Mesh Gearbox

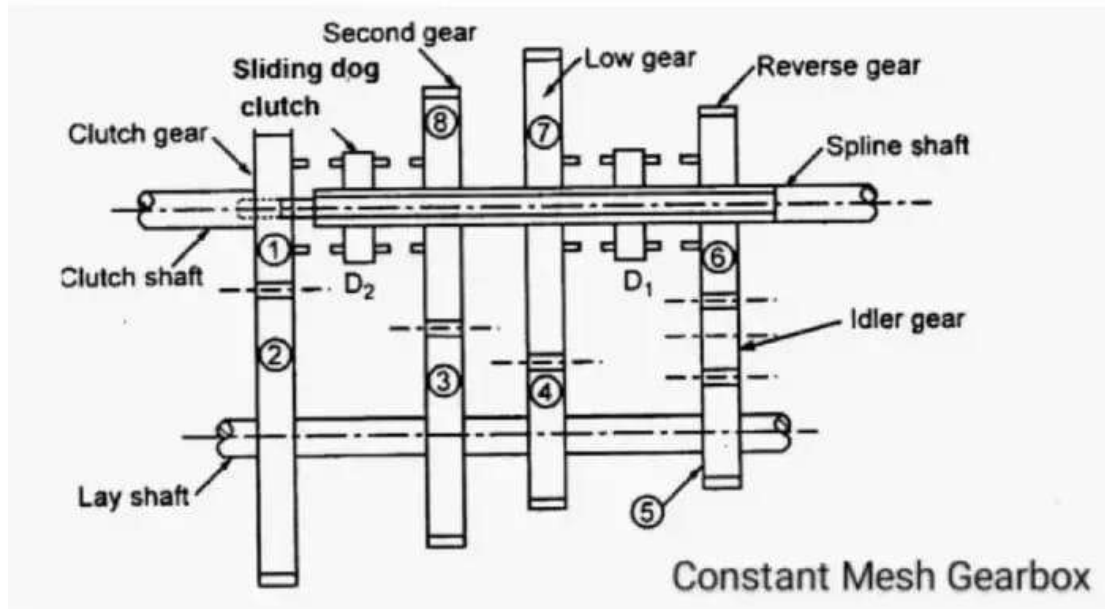

(II) Constant Mesh Gearbox

Figure shows the construction of a constant mesh type gearbox having three forward and one reverse speeds. In this type of gearbox, all gears are constantly in mesh and dog clutches are used for engaging and disengaging the gears. The dog clutches (D) and D2) are mounted on the main shaft. One (D2) is connected between clutch gear and reverse gear whereas the other (D) is placed between low speed gear and reverse gear. movement of dogs. Dog clutch can slide on the shaft and rotate along with it. All gears are rigidly fixed on the counter shaft.

All main shaft and layshaft gears, and idler gears are engaged by dog clutch to obtain opposite and slow speed. Only reverse gears are spur gear type and all others are helical gears.

As compared with the sliding mesh type, the constant mesh type gearbox meshes more readily with the gears having less danger of damaging during meshing because the gear diameters are smaller with few numbers of teeth. So, this type has more defects when compared to a synchromesh type. The necessity of double clutching is needed so that it is not used to any large extent

3. Synchromesh Gearbox

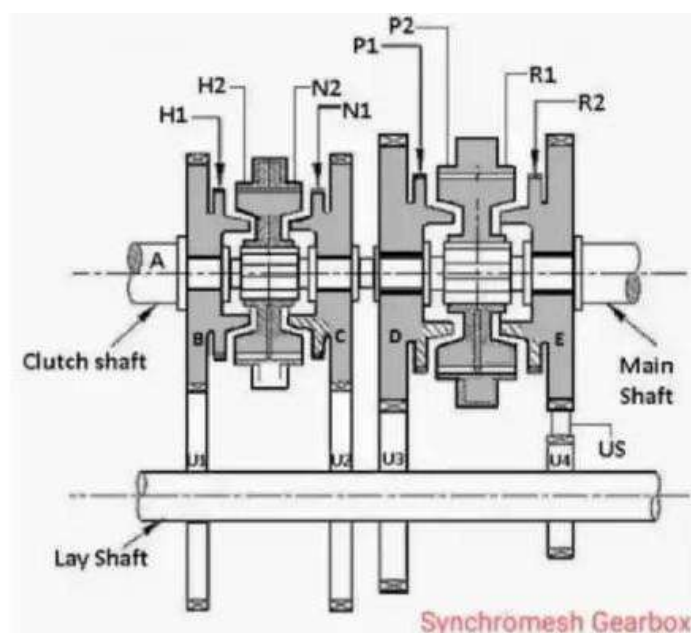

(III) Synchromesh Gearbox

Synchromesh gearbox uses synchronizer instead of sliding dog clutches to affect the ratio change. The synchromesh gearbox is similar to the constant-mesh gearbox, but the synchromesh gearbox is provided with a synchronizer, the device by which two gears to be engaged are first brought into frictional contact which equalizes their speed, afterward they are engaged smoothly.

To engage, when the gear lever is moved the synchronizer cone meets with a similar cone on the pinion. Due to friction, the rotating pinion is made to rotate at the same speed as the

synchronmesh unit. To give a positive drive further, movement of the gear lever enables the coupling to override several spring load balls and the coupling engages with the dogs on the side of the pinion.

Since both pinions and synchronmesh units are moving at the same speed, this engagement is done without noise or damage to the dogs. A slight delay is necessary before engaging the dog teeth so that the cones have a chance to bring the synchronizer and pinion to the same speed.

➤ Epicyclic Gearbox

2. Epicyclic Gearbox

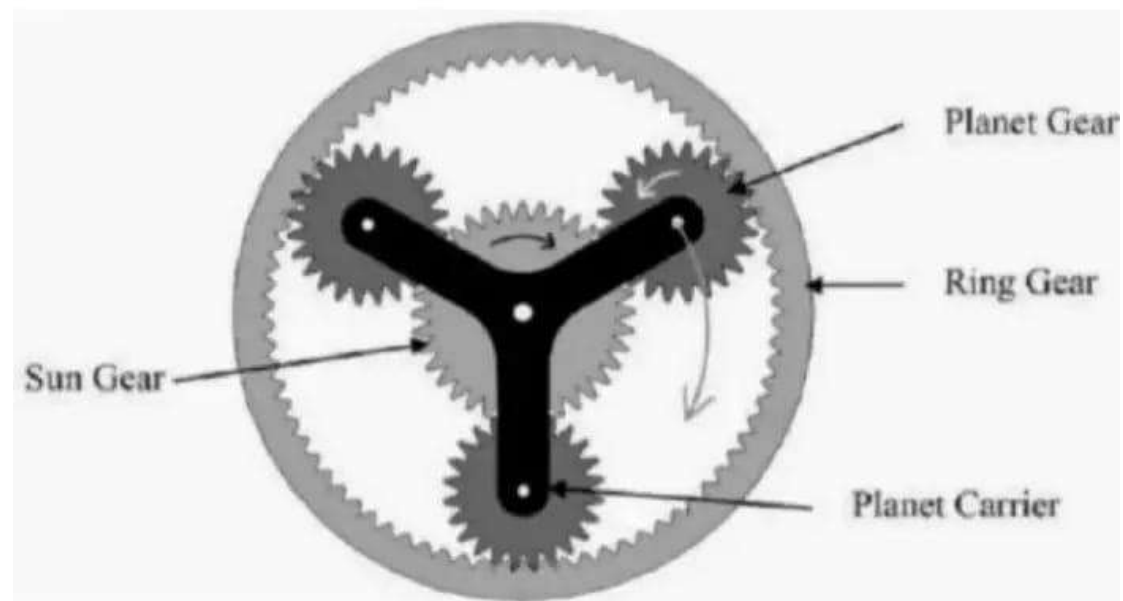

An epicyclic gear train (also known as planetary gear) consists of two gears so that the center of one gear rotates around the center of the other. A carrier connects the centers of two gears and rotates to carry one gear, called planet gear or planet pinion, around the other, called sun gear or sun wheel. The rays of the planet and the sun form traps so that their pitch circles are rolled without slip. A point on the pitch circle of the

planetary gear traces an epicyclic curve. In this simplified case, the sun gear is fixed and there is planetary gear rolled around the sun gear.

An epicyclic gear train can be assembled so the planetary gear is rolled onto a fixed, external gear ring or inside the pitch circle of the ring gear, sometimes called the annular gear. In this case, the curve detected by a point on the planet pitch circle is a hypocycloid.

The combination of epicyclic gear trains with a planet engaging both a sun gear and a ring gear is called planetary gear train. In this case, the ring gear is usually fixed and the sun gear is operated

Purpose Of Gearbox

It helps the engine to disconnect from driving wheels.

It helps the running engine connect to the driving wheel smoothly and without shock.

It provides the leverage between engine and driving wheels to be varied.

This helps in reducing the engine speed in the ratio of 4 : 1 in case of passenger cars and in a greater ratio in case of heavy vehicles like trucks and lorries.

It helps the driving wheels to drive at different speeds.

It gives the relative movement between engine and driving wheels due to flexing of the road spring.

Function Of Gearbox

Torque ratio between the engine and wheels should be varied for fast acceleration and for climbing gradients.

It provides means of reversal of vehicle motion.

Transmission can disconnect from the engine by the neutral position of the gearbox.

Gear Ratio

Gear ratios are geared reduction steps in the gearbox. A gear reduction multiplies the engine torque by gear ratio amount. Torque requirement at the wheel depends on operating conditions.

For example :

Moving a vehicle from a standstill requires much more torque than the peak torque of the engine. Therefore the torque multiplies by the first gear ratio.

Once starting the vehicle and moving using first gear, it requires less torque at the wheels to keep it moving. Hence it requires no multiplication or very less multiplication.

If the vehicle suddenly encounters a gradient , it will require more torque on the wheels to keep the vehicle moving. Hence an intermediate ratio requires.

CONSTRUCTION AND WORKING OF 4 SPEED GEARBOX

Four speed gearbox construction

Manual gearbox is a type of transmission used in motor vehicle applications. This is article about four speed gearbox construction. We will know about how a four speed gearbox works and its construction.

At the beginning we should know the scheme gearbox working of the gearbox and then we can new information about 4-, 5-speed gearbox construction too.

Four-Speed Gearbox Construction

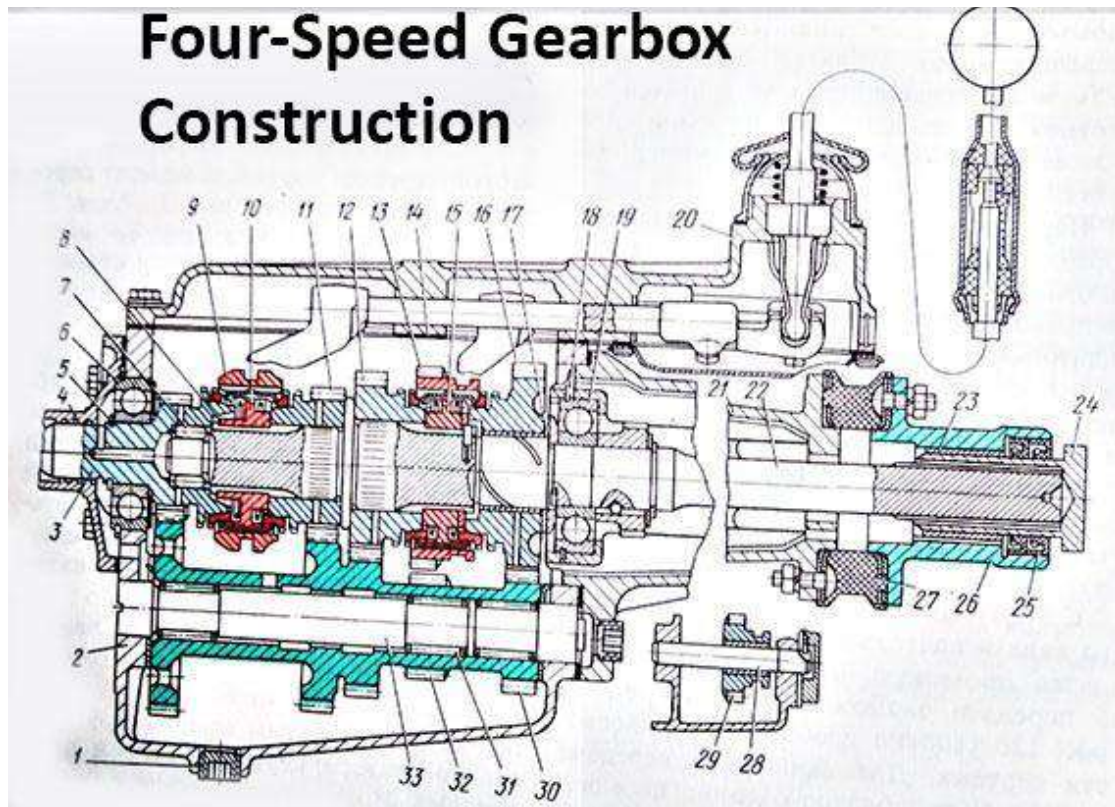

Four-speed Gearbox Construction: 1 – oil drain plug; 2 – gear housing; 3 – drive shaft; 4 – drive shaft bearing cap; 5, 8, 18 – locking rings; 6 – reverse drive shaft bearing; 7 – roller bearing; 9 – synchronizer coupling of third and fourth gears; 10 – synchronizer coupling of the third and fourth gears; 11 – gear wheel of the third speed; 12 – gear wheel of the second speed; 13 – synchronizer coupling of the first and the second gears; 14 – washer; 15 – synchronizer hub of the first and the second gears; 16 – gear wheel of the first gear; 17 – adjusting washer; 19 – ball bearing; 20 – top cap gearbox; 21 – gearbox extension; 22 – driven shaft; 23 – steel-babbit bearing; 24 – screw cap; 25 – stuffing box; 26 – extension flange; 27 – rubber coupling; 28 – axis of intermediate gear wheel of reverse; 29 – intermediate gear wheel of reverse gear; 30 – gear wheels block of intermediate shaft; 31 – needle bearing of intermediate shaft; 32 – gear wheel reverse gear; 33 – axis of intermediate shaft.

The driving shaft 3 of the four-speed gearbox has a gear wheel permanent gearing connect to the block of gear wheels 30 of intermediate shaft. Other gear wheels of this block are in permanent gearing to the gear wheels 11, 12, 16 according with third, fourth, fifth

gears of the driven shaft 22. To turn on all four gears of front moving are used connecting of the sliding couplings 9 and 13 of synchronizers.

WORKING of Four-speed gearbox

When the first speed is on: The crankshaft rotation moment is transmitting to the gear wheels block of intermediate shaft 30 through drive shaft 3, and then to the driven shaft 22 through gear wheel 16, sliding coupling 13 and synchronizer 15 hub of the first and second gears

When the second speed is on: The crankshaft rotation moment is transmitting to the driven shaft though the drive shaft 3, gear wheels block of intermediate shaft, gear wheel 12, sliding coupling 13 and synchronizer 15 hub of the first and second gears.

When the third speed is on: The crankshaft rotation moment is transmitting to the driven shaft though the gear wheel 11, sliding coupling 9 and synchronizer 10 hub of the third and fourth gears.

When the fourth speed is on: the synchronizer of the third and fourth speed connects drive shaft to the driven shaft directly.

When the reverse gear is on: gear wheel 29 is gearing to gear wheel 32 of the intermediate gear wheels block and gear rim of the synchronizer sliding coupling of the first and second gears.

Concept of automatic gear changing mechanisms

The most common type of automatic transmission uses hydraulic power to shift gears. This device combines a torque or fluid coupling converter with gearsets that provide the desired range of gears for the vehicle. The torque converter connects the engine to the transmission and uses pressurized fluid to transfer power to the gears. This apparatus replaces a manual friction clutch and lets the vehicle come to a complete stop without stalling.

As the engine transmits power to the pump of the torque converter, the pump converts this power into transmission fluid that powers the turbine of the torque converter. This apparatus increases the power of the fluid and transmits even more power back to the turbine, which creates a vortex power rotation that spins the turbine and the attached central

shaft. The power created by this rotation is then transmitted from the shaft to the transmission's first planetary gear set.

This type of transmission has what is called hydraulic control. The transmission fluid is pressurized by an oil pump, which allows the speed to change depending on the vehicle's speed, tire revolution per minute, and other factors. The gear pump is placed between the planetary gearset and torque converter, where it pulls and pressurizes transmission fluid from a sump. The pump input leads directly to the housing of the torque converter attached to the flexplate of the engine. When the engine is not running, the transmission does not have the oil pressure needed to operate and thus the vehicle cannot be push-started.

The planetary gear train is a mechanical system in which the gears are connected with a set of bands and clutches. When the driver changes gears, the bands hold one gear still while rotating another to transmit torque from the engine and increase or decrease gears.

The different gears are sometimes called the sun gear, the ring gear, and the planetary gear. The arrangement of the gears determines how much power will flow from one gear to another and out to the drive train of the vehicle when you shift.

Gears of an Automatic Transmission

The gears of an automatic transmission include the following:

> When you shift your vehicle into drive, you engage all available forward gear ratios. This means that the transmission can move between its full range of gears as needed. Six-speed automatic transmissions are the most common number of gears, but older cars and entry-level compact cars may still have either four or five automatic gears.

> Third gear either locks the transmission in third gear or limits it to the first, second, and third gear ratios. This provides the power and traction needed to go either uphill or downhill or to tow a boat, RV, or trailer. When the engine reaches a designated level of revolutions per minute (RPM), most vehicles automatically drop third gear to keep the engine from harm.

> Second gear either locks the transmission in second gear or limits it to the first and second gear ratios. This gear is ideal for going uphill and

downhill in slippery conditions as well as driving during ice, snow, and other types of inclement weather.

> First gear is used when you want to lock the transmission in first gear, although some vehicles will automatically switch out of this gear to protect the engine at a certain RPM. Like second and third gear, this gear is best used for towing, driving uphill or downhill, and when traveling during slippery, icy conditions.

Advantages of an Automatic Transmission

The biggest advantage of an automatic transmission is the ability to drive without the need for a clutch as is required with a manual transmission. Individuals with many disabilities are able to drive using an automatic since operation only requires two usable limbs.

The lack of a clutch also eliminates the need to pay attention to shifting manually and monitoring the tachometer to make the necessary shifts, which gives you more attention to focus on the task of driving.

Many drivers also find it easier to control an automatic transmission at low speeds than a manual transmission. The hydraulic automatic transmission creates a phenomenon called idle creep, which encourages the vehicle to move forward even when idling.

PROPELLER SHAFT

The drive shaft (also called propeller shaft or prop shaft) is a component of the drive train in a vehicle, with the purpose of delivering torque from the transmission to the differential, which then transmits this torque to the wheels in order to move the vehicle. The drive shaft is primarily used to transfer torque between components that are separated by a distance, since different components must be in different locations in the vehicle. A front-engine rear-wheel drive car must have a long drive shaft connecting the rear axle to the transmission since these parts are on opposite sides of the car.

Drive shafts are used differently in different vehicles, varying greatly in cars with distinct configurations for front-wheel drive, four-wheel drive,

and the previously mentioned front-engine rear-wheel drive. Other vehicles also use drive shafts, like motorcycles, locomotives, and marine vessels

Propeller Shaft is the shaft that transmits power from the gearbox to the differential gear in a motor vehicle from the engine to the propeller in a boat or flying machine.

Propeller shaft, sometimes called a cardan shaft, transmits power from the gearbox to the rear axle. Regularly the shaft has a tubular section and is made in maybe a couple piece construction.

The two-piece arrangement is supported at the mid point by an elastic mounted bearing. Short drive shafts are incorporated for the transmission of power from the last drive assembly to the road wheels in both front and rear wheel drive layouts.

FUNCTIONS OF THE PROPELLER SHAFT

In most of the automotive vehicles, the engine is located at the front and the rear wheels of the vehicle are being driven. This arrangement stipulates a longer propeller shaft to be used. In some arrangements two or three propeller shafts are used to make up the length.

In some vehicles, the engine is kept at the front and the front wheels of the vehicle are being driven. In some other vehicles, the engine is at the rear and the rear wheels are being driven. For such arrangements a short propeller shaft is used to drive each wheel.

The engine and the transmission unit are attached to the vehicle frame with some flexible mounting. The rear axle housing with differential and wheels are attached to the vehicle frame by suspension springs.

Due to the above arrangement, the transmission output shaft and the input shaft to the rear axle housing are in different planes. This compels the propeller shaft that connects these two shafts to be kept inclined.

Further, whenever the rear wheels encounter irregularities in the road, the rear axle housing moves up and down, compressing and expanding the suspension springs. As this happens, the angle between the transmission output shaft and the propeller shaft changes. Further, the length to be occupied by the propeller shaft also changes.

The variation in the length of the propeller shaft happens because the propeller shaft and the rear axle housing rotate on arcs with different points as their centres of rotation.

The rear axle housing moves in the shorter arc than that of the propeller shaft. This is because the centre of the rear axle housing arc is the point of attachment of the rear spring or control arm to the vehicle frame. This aspect causes a reduction in the length occupied by the propeller shaft as the angle between the transmission and the propeller shaft increases.

PROPELLER SHAFT

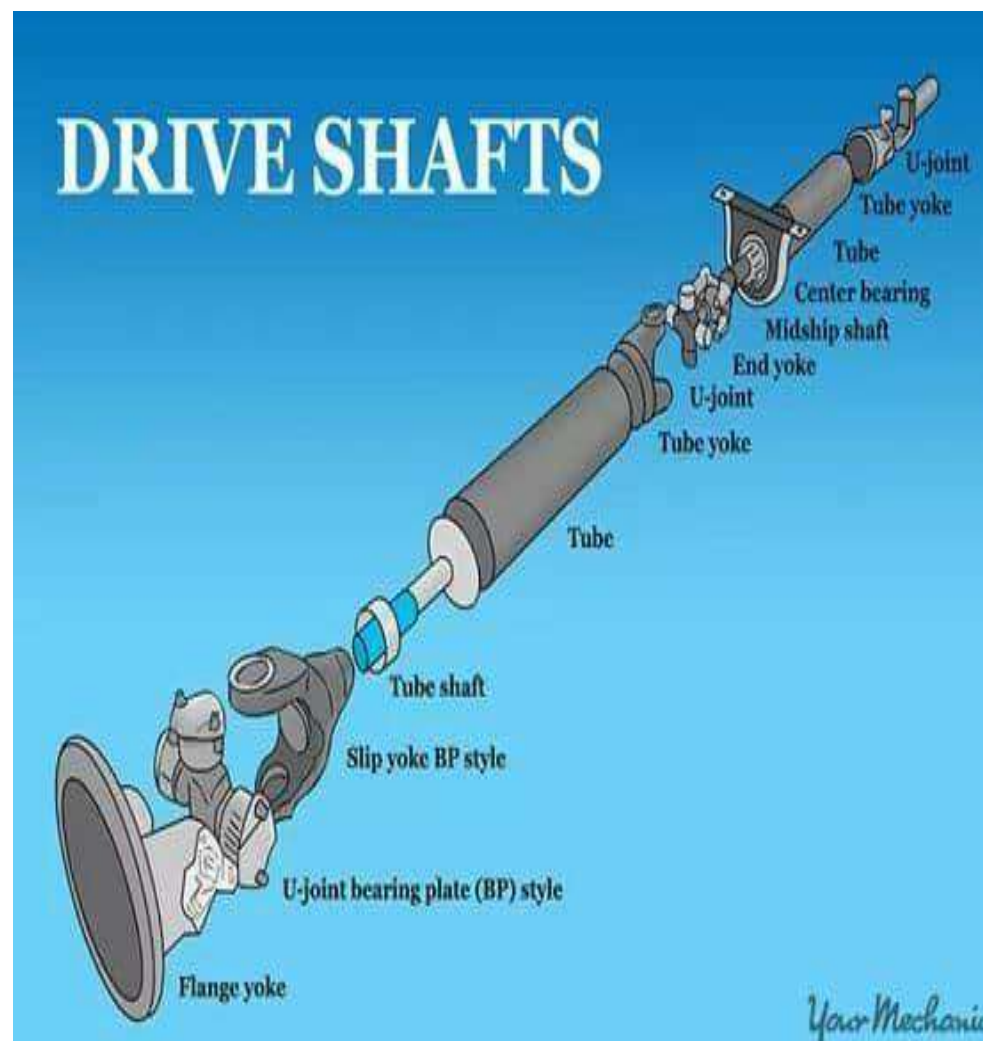

TYPES OF PROPELLER SHAFT:

1. Single-Piece-Type Propeller Shaft:

Used in vehicles with a short distance between the engine and axles, and MR based four-wheel-drive vehicles.

The friction welding adopted at the junction contributes to an improvement in the strength, quality, and durability of the junction.

2-piece-type/3-piece-type Propeller Shaft:

Utilized as a part of vehicles with a long distance between the engine and axles, and Front engine front drive base four-wheel-drive vehicles.

The division of the propeller shaft into two- or three-parts allows the critical number of revolution to be lowered preventing vibration issues from occurring, when the overall length of the shaft increased.

COMPONENTS OF PROPELLER SHAFT:

The propeller shaft transfers engine torque to the rear axle through one or more universal joints.

The splines on the ends of the propeller shaft fit perfectly into the splines in the sleeve. This permits a length variation between the driving and the driven unit to vary slightly without damaging the output and input bearings.

The main bearing supports and guides the propeller shaft.

The flanges associate the propeller shaft to the gearbox.

REQUIREMENTS OF PROPELLER SHAFT:

For achieving efficient functions, the following are expected in a propeller shaft

High torsional strength: Therefore, they are made of solid or hollow circular cross section

Toughened and hardened: Therefore, they are made of superior quality steel and are induction hardened

Efficiently jointed: Therefore they are generally welded by submerged arc carbon dioxide welding process.

Dynamically balanced: Since the phenomenon of whirling may be critical at higher speeds, therefore, propeller shafts are tested on electronic balancing machines.

Reduced thrust loads: Since resonance is dangerous for the life of shaft. It also transmits excessive dynamic force to the shaft's end supports, and so its occurrence should be avoided.

NOTE: Since the propeller shaft sleeve end is pulled out from the transmission extension housing with the transmission still mounted, overflow of the transmission oil, damage of oil seal lip or entrance of dust may result if the vehicle is raised higher toward its front end. Use extreme care in removing the propeller shaft.

DIFFERENTIAL

Functions Of Differential gear Box.

When a four-wheeler (car) takes a turn, the outer wheel turns faster than the inner wheel. Thus, there is relative movement between the inner and outer wheel.

The function of the differential is to permit the relative movement between inner and outer wheels when vehicle negotiates (takes) a turn. The torque transmitted to each rear wheel is equal in this case, although their speed is different.

The differential is made up of a system of gears that connect the propeller shaft and rear axles. It is a part of inner axle housing assembly. The assembly consists of differential, rear axles, wheels, and bearings.

The need of differential gearbox:

When a vehicle travels in a straight line, the two rear wheels turn on the road exactly at the same speed and there is no relative movement between two rear wheels.

But when vehicle takes a turn the outer wheel travels on a longer radius than the inner wheel. The outer wheel turns faster than inner wheel i.e. there is relative movement between two rear wheels. If two rear wheels are rigidly fixed to a rear axle, the inner wheel will slip, which will cause rapid tire wear, steering difficulties and poor road holding. Therefore there must be some device, which will divide the input torque of the transmission system between two rear axles. Differential serves this purpose.

Differential gearbox Location :

Location in a different type of vehicle layouts-

1. In Front-engine front-wheel-drive layout – differential is located at the front next to gearbox.
2. In Rear engine rear-wheel-drive layout – differential is located at the rear next to gearbox.
3. Four wheels drive layout – differential is located at the front as well as rear.
4. Front engine rear-wheel-drive layout – it is located at the rear in between two half shafts.

Principle of differential-

If a vehicle travels in a straight line, the two rear wheels turn exactly at the same speed, and there is no relative movement between them. But when the vehicle takes a turn the outer wheel travels a longer radius than the inner wheel i.e. there is relative movement between the two rear wheels. The outer wheel turns faster and covers a larger distance than the inner wheel. The inner wheel makes a larger angle than the outer wheel. thus the vehicle negotiates the turn safely.

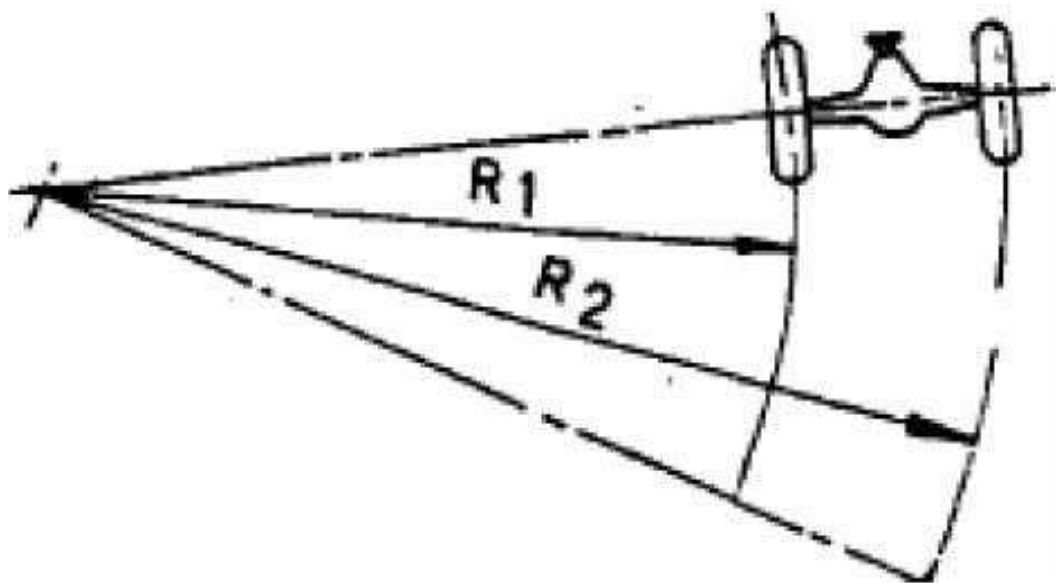

Figure: Principle of Differential

DIFFERENTIAL GEARBOX DIAGRAM

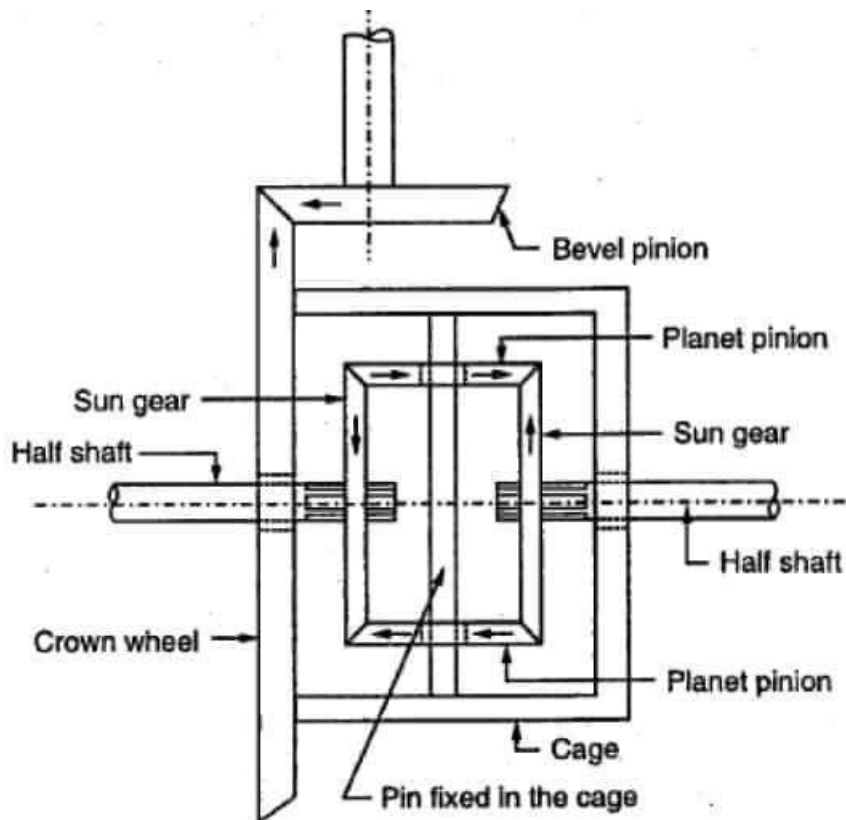

Figure: Working of differential

Construction of differential:

Major Components of Differential

The following main components are used in the differential assembly.

1. Drive pinion or Bevel pinion
2. Ring gear or Crown wheel
3. Differential case
4. Differential side gear or Sun gears
5. Differential pinions (or) Planet gears
6. Axle shafts or Half shafts
7. Pinion shaft or Cross pin (or) spider.

Figure. shows the basic parts of the type of differential used in rear-wheel-drive cars.

On the inner ends of each axle a smaller bevel gear called differential side gear is mounted. Two bevel gears are put together to mesh both driving and driven shafts at an angle of 90° . The differential case is mounted with two-wheel axles and differential side gears. The differential case has bearings that rotate two axle shafts. Then, the two pinion gears and their supporting shaft, called pinion shafts, are fitted into the differential case. Then, the pinion shaft meshes with the two differential side gears connected to the inner ends of the axle shafts.

The ring gear is bolted to a flange on the differential case. The ring gear rotates the differential case. Finally, the drive pinion is mounted. The drive pinion is assembled with the differential housing called differential case or carrier. The driver shaft is connected with the drive pinion by a universal joint and it meshes with the ring gear. So, the drive pinion is rotated when the drive shaft turns. Thus, the ring gear is rotated.

WORKING OF GEARBOX

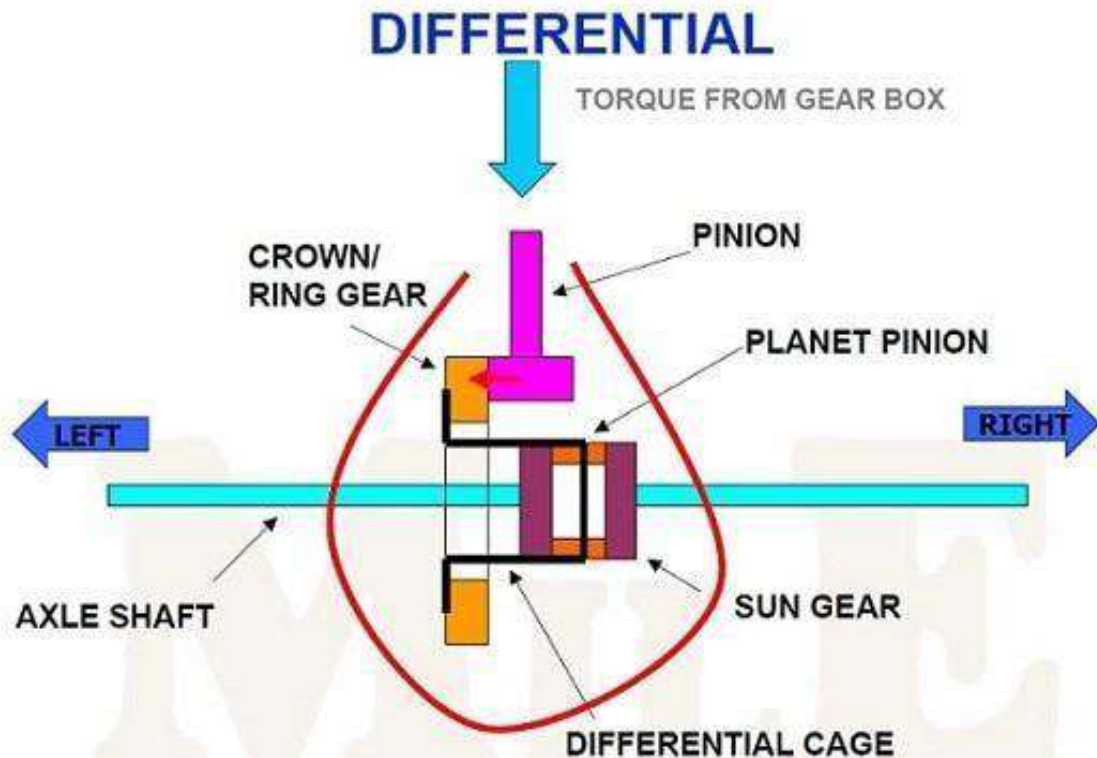

Working of differential gearbox :

1. When Running Straight:

When the vehicle moves in a straight line, the power comes from the propeller shaft to the bevel pinion which drives the crown wheel. Then it is carried to the differential cage in which a set of planet pinions and sun gears are located. From the sun gear it is transmitted to the road wheels through-axle half shafts. In this case, the crown wheel, differential cage, planet pinions, and sun gears all turn as a single unit and there is no relative motion between the sun gear and planet pinion. The planet pinions do not rotate about their own axis. The road wheels, half shafts, and sun wheels offer the same resistance to being turned and the differential gearing does not therefore operate. Both the road wheels turn at the same speed.

2. When taking a turn:

When the vehicle takes a turn, the inner wheel experiences resistance and tends to rotate in the opposite direction. Due to this the planet pinions start rotating about their own axis and around the sun gear and transmit more rotary motion to the outer side sun gear. So that outer sun gear rotates faster than the inner sun gear. Therefore the outer road wheel runs faster than the inner road wheel and covers a more distance.

TYPES OF DIFFERENTIAL

There are three types of differential :

- (a) Conventional type,
- (b) Non-slip or self-locking type, and
- (c) Double reduction type.

1) Conventional Type

Conventional type differential described in Section 5.6 delivers the same torque to each rear wheel. If any of the wheels slips due to any reason the wheel does not rotate and the vehicle does not move.

2) Non-slip or Self Locking Type

Non-slip or self-locking type differential overcomes this drawback. Its construction is similar to that of conventional type differential. But, two sets of clutch plates are provided additionally. Also, the ends of planet shafts are left loose in notches provided on the differential cage.

3) Double Reduction Type

Double reduction type differential provides further speed reduction by additional gear. This type of differential is used in heavy-duty automobiles which require larger gear reduction between engine and wheels.

2.0 BRAKING SYSTEM

A brake is one of the most important controls of the vehicle. This is a combination of some interactive parts. It absorbs energy from the moving part and slows down the vehicle with the help of friction.

Functions of Brake System:

The function of the brake system is to stop the vehicle within the smallest possible distance and hence this is done by converting the kinetic energy of the vehicle into the heat energy which is dissipated into the atmosphere.

Types of Brake System in Automobile:

The brake system in an automobile can be classified into these following categories:

- Mechanical Brake
- Disc Brake
- Hydraulic Brake
- Power-assisted Brake
- Air Brake
- Electric and
- Hand brake System

Let me go through all these break systems.

Mechanical Brake:

The mechanical brake is used in small power automobiles like scooters, motorcycles and some modern vehicles. The figure of the mechanical brake is shown below:

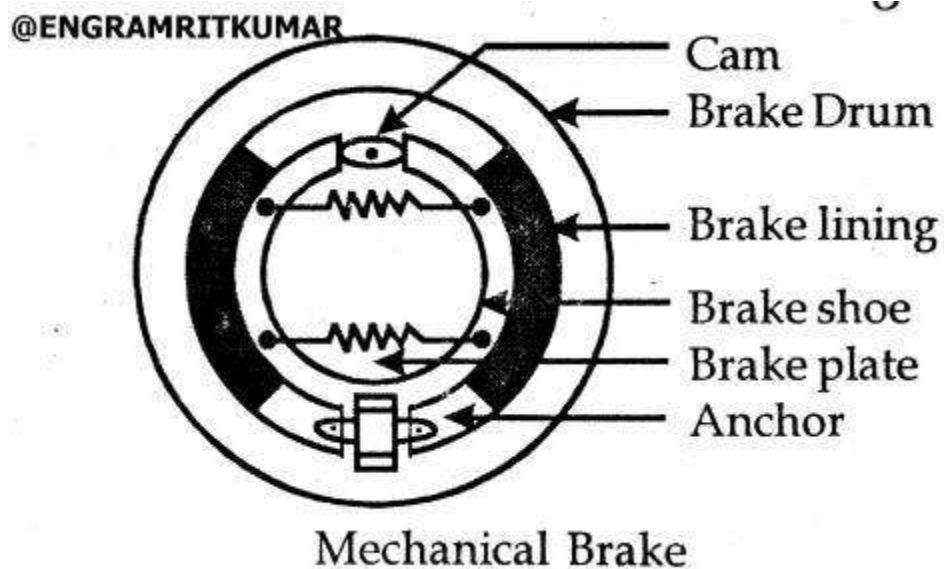

As the brake pedal is pressed cam rotates, which pushes the brake shoes outwards and hence brake lining provided on the outer surface of the shoes rub against rotating the drum and hence slow down or stops the vehicles because the drum is connected to the wheels.

As the pedal is released, due to retracting spring force shoes return to its original position.

Disc Brake:

The disc brake is used in motor vehicles and cars, etc.

When the pedal is pressed piston pushes the pad by the pressure of the hydraulic fluid. The diagram is shown below:

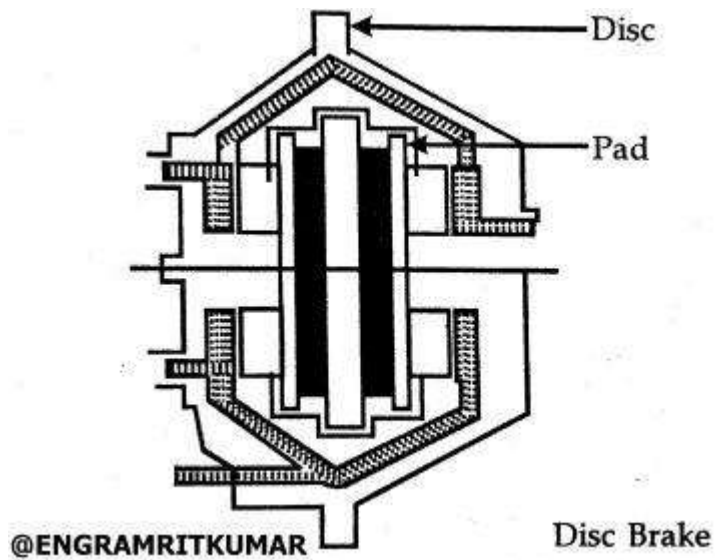

These friction pad rub against the rotating disc connected to the wheels of the vehicle and thus braking takes place.

And as the pedal is released friction pad returns to its original position between the pressure of hydraulic fluid reduces.

Hydraulic Brake:

Hydraulic brake works on the principle which is based on Pascal's principle, which states that "confined liquid transmits pressure without loss in all direction".

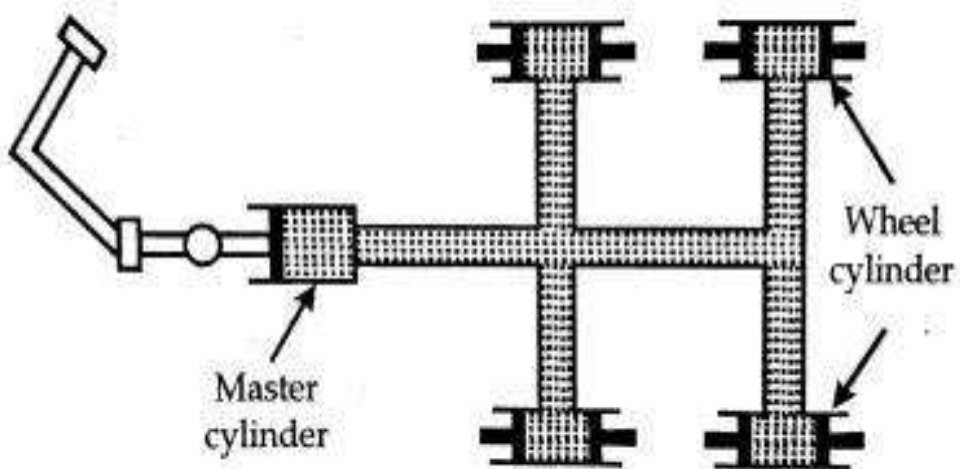

This is simple in construction and has an equal braking effort to all wheels and smooth operation.

When the brake pedal is pressed, fluid from the master cylinder enters into the wheel cylinders through pipelines by the force of the piston.

Due to the liquid force, the piston of the wheel cylinder pushes outward which pushes the shoes outward.

Lining rub against the drum and hence braking take place.

Now when the pedal is released, the piston of the master cylinder moves backward and fluid from the wheel cylinder moves to the master cylinder through the check valve.

This type is commonly used in all cars etc.

Master Cylinder:

The master cylinder is the heart of the hydraulic brake system.

It consists of two chambers:

- The reservoir.
- Compression chamber, in which piston reciprocates.

The piston is connected to the brake pedal through the piston rod. From the reservoir, fluid enters the compression chamber through the parts as shown.

The master cylinder is connected to the wheel cylinder through the pipe.

The check valve is provided in order to give passage for entering fluid from the wheel cylinder to the master cylinder when the pedal is released.

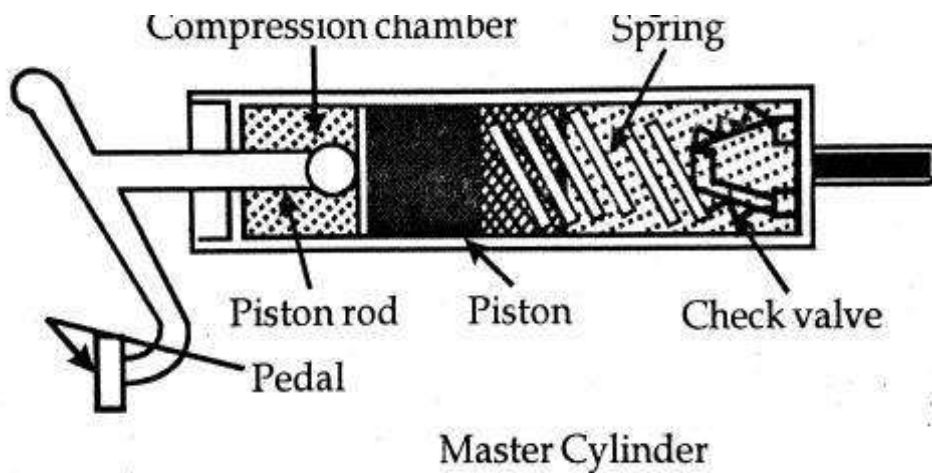

Power-assisted or Vacuum brake:

The line diagram indicates the construction of a power-assisted or vacuum brake as shown below.

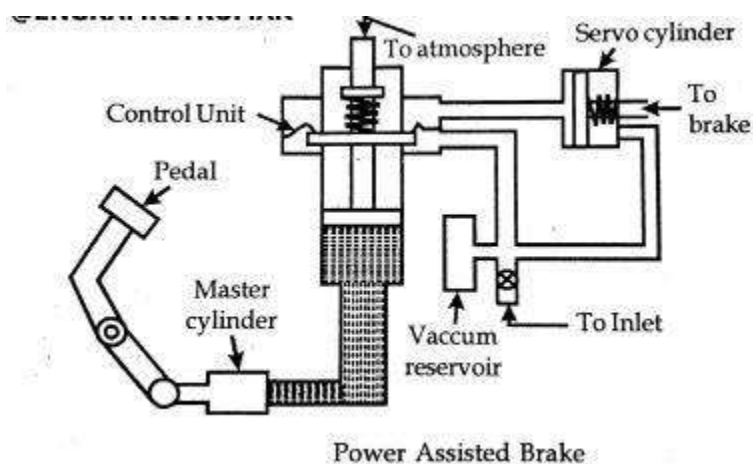

As the brake pedal is pressed, the fluid pressure causes the upper valve of a control unit to open and lower the valve to close.

Thus left the side of the [servo cylinder piston](#) is exposed to atmosphere and vacuum acts on the right side, which causes the braking effort.

Braking takes place by suction from the engine inlet manifold.

Air Brake:

This type of air brake system is commonly used in heavy vehicles such as buses, trucks, etc.

In this also when the brake pedal is pressed, air to atmosphere enters the compressor through the air filter to the reservoir through unloader valve.

From unloader valve air enter brake chamber through brake valve.

Brake valve is fitted in order to control the intensity of braking. Thus braking takes place.

When the pedal is pressed shoes return to its original through position through the spring force.

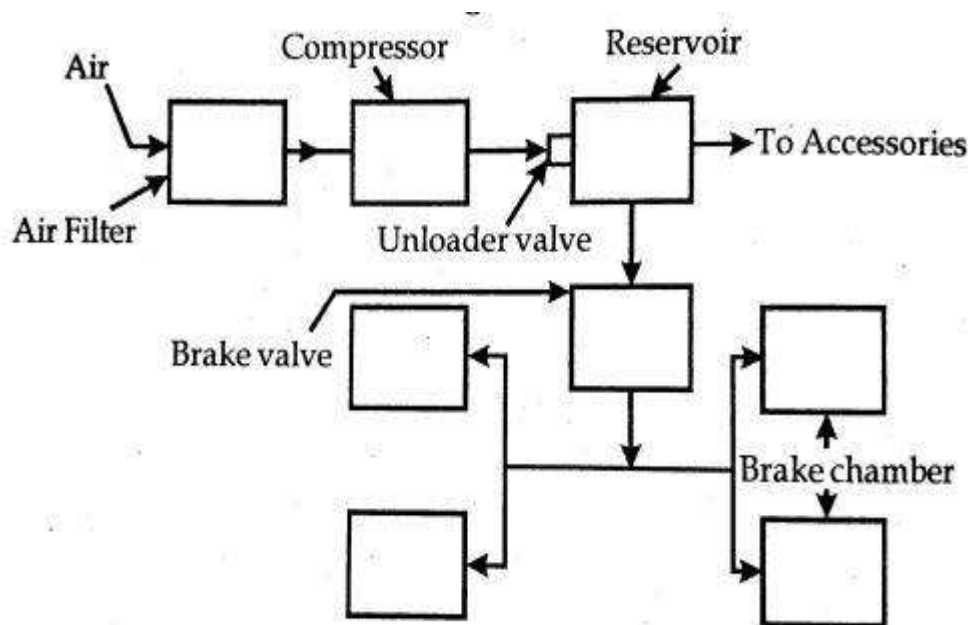

Girling Mechanism Brake:

This system consists of an expander used for braking and adjuster unit to adjust the brake shoes when desired.

As the brake pedal is pressed, the pulls rod of expander pulled out which pulls out the conical wedge.

The brake shoe connected to the conical wedge through plunger and steel roller ball pulls outward. Thus braking the wheel.

When the pedal is released, spring force brings the brake shoe to its original position. It requires less friction. Without jacking up vehicles brakes can be adjusted.

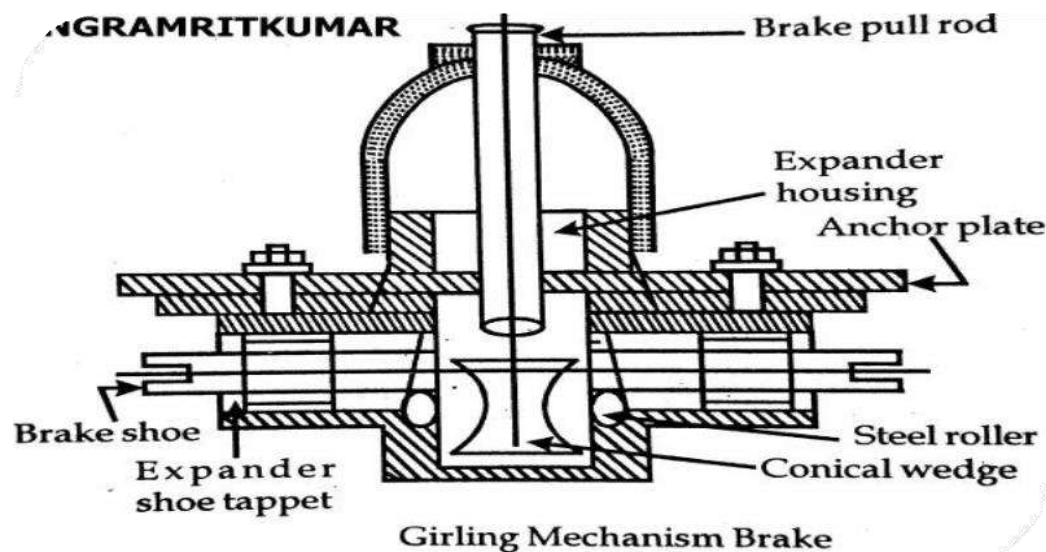

Electrical Brake System:

The principle of working of this type of brake is to utilize the [electromagnetic force on the brake shoes](#).

It consists of an electromagnet, armature disc.

An electromagnet is mounted on the backplate and armature disc is fed to the drum.

This is simple in construction.

For working, electric current for the battery is utilized to energize the electromagnet which actuates the cams that expands the shoes. Thus braking the wheel.

Hand brake System:

Hand brakes or the parking brakes operate independently of the foot brakes.

These are used for parking on slopes or while waiting at traffic lights, where the handbrake function is mainly to minimize accidents.

This brake is applied after the foot brake is applied.

These are mechanical brakes.

Apart from the hydraulic braking system, all cars have a mechanical handbrake acting on two wheels - usually the rear ones

The handbrake gives limited braking if the hydraulic system fails completely, but its main purpose is as a parking brake.

The handbrake lever pulls a cable or pair of cables linked to the brakes by a set of smaller levers, pulleys, and guides whose details vary greatly from car to car.

A ratchet on the handbrake lever keeps the brake on once it is applied. A push-button disengages the ratchet and frees the lever.

On drum brakes, the handbrake system presses the brake linings against the drums.

Disc brakes sometimes have a comparable handbrake arrangement, but because it is difficult to place the linkage on a compact caliper, there may be a completely separate set of handbrake pads for each disc.

Principal Parts of the Vacuum Brake System

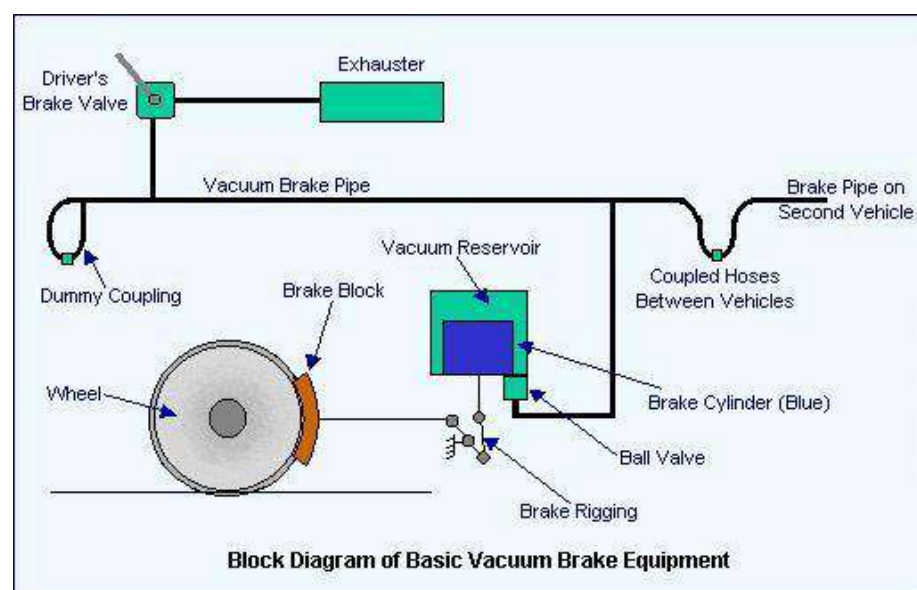

1) Driver's Brake Valve:

driver controls the brake using this. It has the following positions: "Release", "Running", "Lap" and "Brake On". "Neutral" or "Shut Down" positions are also available which locks the valve out of use. The "Release" position connects the exhauster to the brake pipe and switches the exhauster to full speed. This raises the vacuum in the brake pipe as quickly as possible to get a release. The exhauster keeps running but at its slow speed in the "Running" position. This ensures that the vacuum is maintained against any small leaks or losses in the brake pipe, connections and hoses. "Lap" is used to shut off the connection between the exhauster and the brake pipe to close off the connection to atmosphere after a brake application has been made. "Brake On" closes off the connection to the exhauster and opens the brake pipe to atmosphere.

2) Exhauster

A two-speed rotary machine fitted to a train to evacuate the atmospheric pressure from the brake pipe, reservoirs and brake cylinders to effect a brake release.

3) Dummy Coupling:

a dummy coupling point is provided At the ends of each vehicle to allow the ends of the brake pipe hoses to be sealed when the vehicle is uncoupled.

4) Coupled Hoses:

The brake pipe is carried between adjacent vehicles through flexible hoses.

5) Vacuum Reservoir:

a vacuum reservoir is provided on, or connected to the upper side of the piston to ensure there is always a source of vacuum available to operate the brake.

6) Brake Cylinder (shown in blue):

The movement of the piston contained inside the cylinder operates the brakes through links called "rigging".

7) Brake Rigging:

the movement of the brake cylinder piston transmits pressure to the brake blocks on each wheel through this system.

8) Brake Block:

the friction material which is pressed against the surface of the wheel tread by the upward movement of the brake cylinder piston.

9) Ball Valve:

The ball valve is needed to ensure that the vacuum in the vacuum reservoir is maintained at the required level, i.e. the same as the brake pipe, during brake release but that the connection to the brake pipe is closed during a brake application.

ADVANTAGES

- simple in design
- ability to get partial release , something the pneumatic brake could not do without additional equipment
- greater amount of safety because the vacuum lossage results in the braking of the vehicle
- highly reliable in the case of rail wagons
- Permits the automatic application of brakes down the entire length of the train from a simple control in the drivers hand
- vacuum brakes are also fail safe since the vacuum is used for applying the brake

CONCLUSION

The vacuum brake was considered preferential to the air brake in railroad applications largely because it was cheaper to install on a steam locomotive. Air brakes required a steam-powered compressor – bulky, noisy, unsightly and using a lot of power, while the vacuum ejector used to generate vacuum was a much simpler device. It has the advantage of being simple in design and of having the ability to get a partial release, something the air brake could not do without additional equipment.

3.0 IGNITION & SUSPENSION SYSTEM:

Describe the Battery ignition and Magnet ignitionsystem

A battery Ignition System is used in an automobile to produce a spark in the spark plug with the help of a Battery. It is generally used in the 4-wheeler vehicle but nowadays it is also used in two-wheeler vehicles where a 6-volt or 12-volt battery supplies the current to the ignition coil.

Parts of Battery Ignition System:

The main components of Battery Ignition system are listed below:

1. Ignition switch
2. Battery
3. Ignition coil
4. Ballast resistor
5. Contact breaker
6. Distributor
7. Capacitor
8. Spark Plug

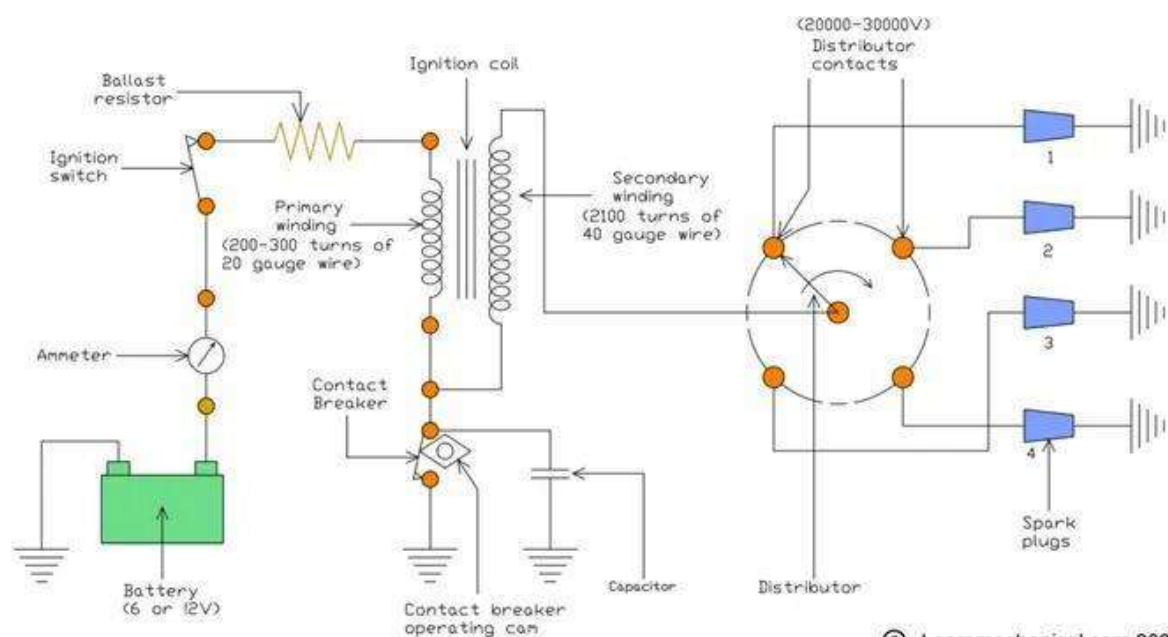

© Learnmechanical.com 2020

Diagram of Battery Ignition System, Learn Mechanical

#1 Ignition Switch:

It is used for ON or OFF the engine. One end of the switch is connected with the Primary Winding of Ignition Coil via Ballast Resistor, and another end is connected with the Battery.

Basically when the key is put inside it and turned the switch in ON position then the circuit is completed (Close Circuit), and when moved towards the OFF position than its work as an open circuit. Nowadays, this switch is replaced by the Push Button, and this system is called a keyless system.

#2 Battery:

The battery is provided for supply the initial current to the ignition system more specifically ignition coil. Generally, the voltage of the battery is 6V or 12V or 24 V. In an automobile there are two types of Battery use widely, one is lead-acid battery and another one is the alkaline battery. Although there are Zinc Acid Battery and Lithium-Ion Battery is used in modern vehicles.

#3 Ignition coil:

It is the main junction or you can say the main part of Battery Ignition System. The main purpose of it is to step up battery voltage so that it is sufficient for generates the spark.

It is working as a step-up transformer, and have two winds, one is primary which have a lesser turn, and the other one is secondary which have a higher number of turn.

#4 Ballast resistor:

This is used to limit the current in the ignition circuit and generally made of Iron. It is placed in series between the Ignition Switch and Ignition Coil. However, it is used in old automobile vehicles.

#5 Contact Breaker:

The contact breaker is an electrical switch which is regulated by the cam and when the breaker is open, current flows through the condenser and charges it.

#6 Distributor:

It is used in the multi-cylinder engine, and its purpose is to regulate spark in each [spark plug](#) at the correct sequence.

There are two types of distributors.

- Carbon Brush Type
- Gap Type

Carbon Brush Type:

It consists of Carbon Brush which slides over the metallic section embedded in the distributor cap.

Gap Type:

In this type, the rotor arm is passed through the metallic section of the distributor cap but it does not touch the surface of the distributor cap. That's why it is called Gap Type Distributor.

#7 Capacitor:

A capacitor is a storing device where electrical energy is stored. It is fitted parallel to the contact breaker, when the current drops then it supplies the additional current so that the spark is produced. It is made of two metal plates separated by air or any other insulating material.

#8 Spark Plug:

Spark Plug is another important part of Battery Ignition system. Here the actual spark is generated for the combustion of fuel or charge. If there is more than one spark plug exists then each one is connected separately with the distributor and gives the spark in the sequence.

Working Principle of Battery Ignition System:

In Battery Ignition System, when the Ignition Switch is turned on then the current will flow to the primary circuit through ballast resistor, primary winding and contact breaker

The flowing current induces a magnetic field around the primary winding, the more current we supply the more magnetic field will generate. At a certain time, the contact breaker opens the current is flowing through the primary winding and falls. This sudden fall of

current generates very high voltage around 300 V in the primary winding section.

Due to this immense amount of voltage the capacitor comes into the charging state when the capacitor charged fully then it starts delivering the current towards the battery, due to this reverse flowing of the current and already induced magnetic field in the primary winding, a very high voltage of 15000 V to 30000 V is generated in the secondary winding.

This high voltage current then transferred to the distributor via high tension cable, where already a rotor rotates inside the distributor cap and has metallic segments embedded on it. So when its start rotating then at a certain stage it opens the contact breaker point which allows the high voltage current to transferred to the spark plugs through the metallic segments.

So when the high voltage current reaches the spark plug then its generates a high intensity of spark inside the engine cylinder, which allows the combustion fuel to burn.

Advantages of Battery Ignition System:

These are the following advantages of Battery Ignition System:

- The intensity of spark is good.
- It can also provide a high concentration of spark even in low engine speed or starting of Engine.
- The maintenance of this ignition system is very less compared to others.

Disadvantages of Battery Ignition System:

The disadvantages are:

- Efficiency decreased with a reduction in spark intensity.
- Occupies more space.
- Efficiency decreased with a reduction in spark intensity.
- Need periodic maintenance is needed for Battery only.

Applications of Battery Ignition System:

Here is the application of it:

- Battery Ignition System is used in Automobile (Car, Bus, Truck even in the Bike) to produce the Spark so that Combustion fuel can be burned

MAGNET IGNITION SYSTEM

Magneto ignition system is an ignition system in which magneto is used [produces high voltage] for the generation of electricity and further that electricity is used in several things like to run the vehicles. This is basically used in two-wheeler vehicles (Spark Ignition Engine) nowadays.

Parts of Magneto Ignition System:

The main parts of Magneto Ignition System are:

1. Transformer core
2. Contact Breaker
3. Cam
4. Capacitor
5. Ignition Switch
6. Distributor
7. Spark Plug

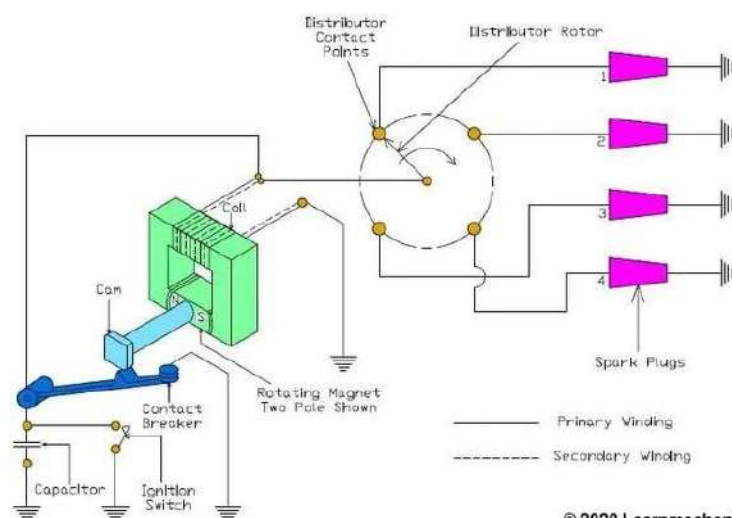

Magneto Ignition System

#1 Transformer core:

There are two types of winding we can see in Magneto Ignition System, those are:

1. Primary Winding: The main function of this winding is to draw the power from the source.
2. Secondary Winding: This winding has more turns of wire (the number is 1000 of turns of wire) as compared to the primary winding. This is connected to the Distributor (Which is having a rotor).

#2 Contact Breaker:

The contact breaker is regulated by the cam and when the breaker is open, current flows through the capacitor and charges it.

#3 Cam:

Cam is connected to the North and south magnet.

#4 Capacitor:

The main work of the capacitor is to Store the charger. The capacitor is used here is a simple electric capacitor.

#5 Ignition switch:

Works for of and on the vehicles and this is set to the parallel of the capacitor because it helps to avoid the damage of excessive air.

#6 Distributor:

This is connected to the spark plug and Distributor having the rotor.

#7 Spark Plug:

The main work of the spark plug is firing the explosive mixture in the IC engine.

Working Principle of Magneto Ignition System:

In the Magneto Ignition System, magneto is used. When the engine of the system starts, it helps the magneto to rotate and thus it's producing the energy in the form of high voltage then, one end of the magneto is grounded through a contact breaker, and the ignition capacitor is connected to its parallel.

The contact breaker is regulated by the cam and when the breaker is open, current flows through the capacitor and charges it.

Now the capacitor is acting as a charger now, the primary current flow is reduced, thus reducing the overall magnetic field, generated in the system.

This increases the voltage in the capacitor. This increased high voltage in the capacitor will act as an EMF thus producing the spark, at the right spark plug through the distributor.

And at the starting stage, the speed of the engine is low and hence the voltage generated by the magneto is low.

But as the rotating speed of the engine increases, it also increases the voltage generated by the magneto thus the flow of the current is also increased.

Schematic Diagram of Magneto Ignition System:

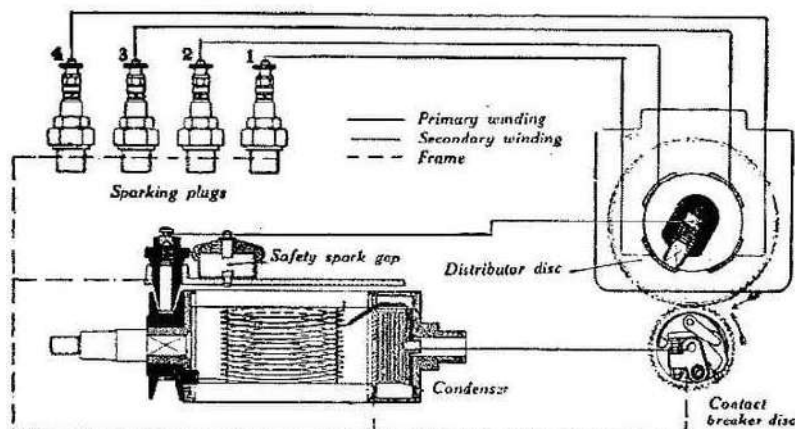

Circuit Diagram of Magneto Ignition System:

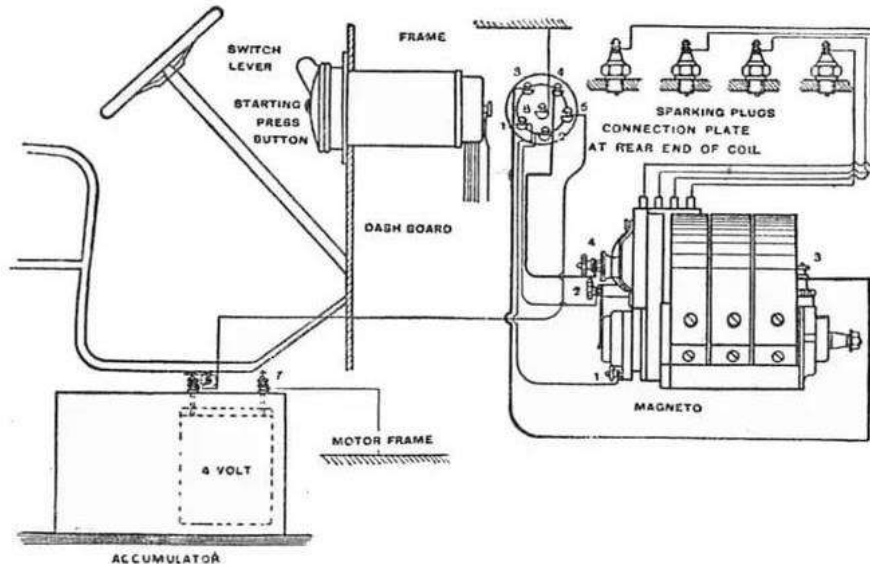

Applications of Magneto Ignition System:

Magneto Ignition System nowadays widely used in:

- *This system is used for the generation of electricity (In case of Battery system their Battery is used) and to run the vehicles.*
- This is basically used in two-wheeler vehicles (SI Engine) nowadays.
- A rotating magnet produces high voltage.

. And also this is used in various places like: Tractors, Outboard Motors, Washing Machines, Buses, Power Units, Marine Engines, and Natural Gas Engines.

Advantages of Magneto Ignition System:

These are the following advantages of Magneto Ignition System:

- This system requires less maintenance as compared to the Battery ignition system.
- This is more useful because no battery is used.
- It occupies less space.
- An electric circuit is generated by the magneto
- No battery is needed, so no problem of battery discharge
- Efficiency improves due to high-intensity spark.

Disadvantages of Magneto Ignition System:

Although there are some disadvantages:

- During starting, the quality of spark is poor due to low speed.
- This is a little expensive as compared to another ignition system.

Some FAQ:

What is Magneto Ignition System?

The magneto ignition system is an ignition system in which we use magneto for the generation of electricity.

How do magneto ignition systems work?

When the engine of the system starts, it helps magneto to rotate and thus it's producing the energy in the form of high voltage. This increased high voltage in the capacitor will act as an EMF thus producing the spark, at the right spark plug through the distributor.

What are the 3 types of ignition systems?

The 3-types of Ignition Systems are:

1. Battery Ignition System
2. Magneto Ignition System
3. Electronic Ignition System

Spark plugs: Purpose, construction and specifications

A spark plug is an electrical device that fits into the cylinder head of some internal combustion engines and ignites compressed aerosol gasoline by means of an electric spark. Spark plugs have an insulated center electrode which is connected by a heavily insulated wire to an ignition coil or magneto circuit on the outside, forming, with a grounded terminal on the base of the plug, a spark gap inside the cylinder.

PURPOSE OF SPARK PLUG

1. To ignite the air/fuel mixture.

Electrical energy is transmitted through the spark plug, jumping the gap in the plug's firing end if the voltage supplied to the plug is high enough. This electrical spark ignites the gasoline/air mixture in the combustion chamber.

2. To remove heat from the combustion chamber.

Spark plugs cannot create heat, they can only remove heat. The temperature of the end of the plug's firing end must be kept low enough to prevent pre-ignition, but high enough to prevent fouling. The spark plug works as a heat exchanger by pulling unwanted thermal energy from the combustion chamber and transferring heat to the engine's cooling system. The heat range of a spark plug is defined as its ability to dissipate heat from the tip.

CONSTRUCTION

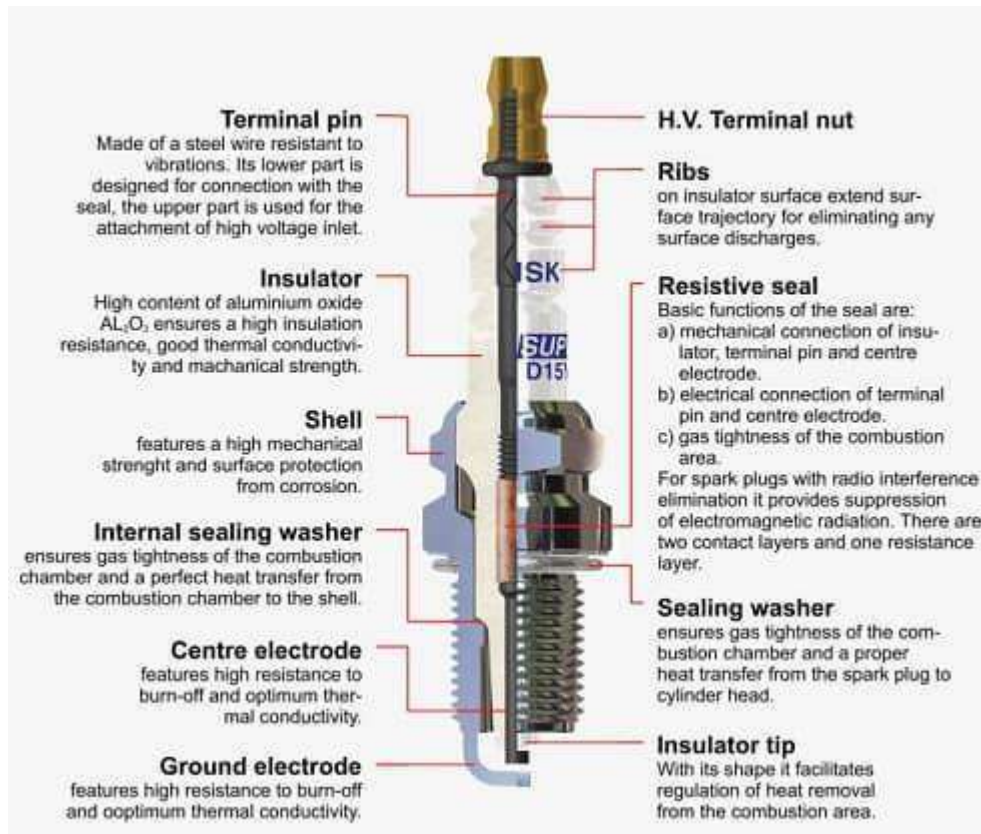

spark plug construction

1. Ribs-

Insulator ribs provide added protection against secondary voltage or spark flashover and also help to improve the grip of the rubber spark plug boot against the plug body.

The insulator body is molded from aluminum oxide ceramic. In order to manufacture this part of the spark plug, a high-pressure, dry molding system is utilized. After the insulator is molded, it is kiln-fired to a temperature that exceeds the melting point of steel. This process results in a component that features exceptional dielectric strength, high thermal conductivity and excellent resistance to shock.

2. Insulator:

The insulator body is molded from aluminum oxide ceramic. In order to manufacture this part of the spark plug, a high-pressure, dry molding system is utilized. After the insulator is molded, it is kiln-fired to a temperature that exceeds the melting point of

steel. This process results in a component that features exceptional dielectric strength, high thermal conductivity and excellent resistance to shock.

The pointer shows the spark plug insulator. As mentioned above, it is formed from aluminum oxide ceramic. The outer surface is ribbed to provide grip for the spark plug boot and to simultaneously add protection from spark flashover (crossfire).

3. Hex:

The hexagon provides the contact point for a socket wrench. The hex size is basically uniform in the industry and is generally related to the spark plug thread size.

4. Shell:

The steel shell is fabricated to exact tolerances using a special cold extrusion process. Certain types of spark plugs make use of a steel billet (bar stock) for shell construction.

5. Plating:

The shell is almost always plated. This enhances durability and provides for rust and corrosion resistance. The steel shell is fabricated to exact tolerances using a special cold extrusion process or in other specialized cases, machined from steel billet. The hexagon machined onto the shell allows you to use a socket wrench to install or remove the plug.

6. Gasket:

Certain spark plugs use gaskets while other examples are "gasketless." The gasket used on spark plugs is a folded steel design that provides a smooth surface for sealing purposes. Gasketless spark plugs use a tapered seat shell that seals via a close tolerance incorporated into the spark plug.

7. Threads:

Spark plug threads are normally rolled, not cut. This meets the specifications set forward by the SAE along with the International Standards Association.

8. Ground electrode:

There are a number of different ground electrode shapes and configurations, but for the most part, they are manufactured from nickel alloy steel. The ground electrode must be resistant to both spark erosion and chemical erosion, both under massive temperature extremes.

9. Center electrode:

Center electrodes must be manufactured from a special alloy that is resistant to both spark erosion and chemical corrosion. Keep in mind that combustion chamber temperatures vary (and sometimes radically). The center electrode must live under these parameters.

10. Spark gap electrode gap:

The area between the ground electrode and the center electrode is called the gap. Center electrodes must be manufactured from a special alloy that is resistant to both spark erosion and chemical corrosion.

11. Insulator nose:

There are a large number of insulator nose shapes and sizes available, but in essence, the insulator nose must be capable of shedding carbon, oil and fuel deposits at low speeds. At higher engine speeds, the insulator nose is generally cooled so that temperatures and electrode corrosion are reduced.

WORKING PRINCIPLE

The spark plug is connected to a high voltage source like the magneto or the ignition coil at one end. The other end with the two electrodes is immersed into the combustion chamber. When current passes through the terminal and into the main center electrode, a potential difference (voltage drop) is created between two electrodes. The gas mixture that occupies the gap between them acts as an insulator and thus the electricity doesn't flow beyond the tip of the center electrode.

But as the voltage increases, the gases in the gap begin to get energized. Once the voltage increases to the point that crosses the dielectric strength (resistance to conduct electricity) of the gases, they become ionized. Once the gases get ionized, they begin to act as conductors and permit the current to travel through the insulating gap. When the dielectric strength is crossed, the electrons begin to surge through that gap. This sudden movement of electrons rapidly increases the heat in that region due to which they begin to expand rapidly causing a mini explosion which results in the formation of a spark.

TYPES

Spark Plugs can be put into two different primary classifications, based on their operating temperatures and based on their construction.

Based on Operating Temperatures

Once the combustion process is completed in the combustion cycle, the heat generated needs to dissipate. The heat escapes through the exhaust gases, the cylinder wall of the engine and the spark plug surface. Based on the operating temperature and level of heat dissipation, spark plugs can be classified into two types:

1. Hot Spark Plug:

A hot spark plug operates in a higher temperature range. It has a lesser ceramic area which is used to insulate the heat. A hot spark plug dissipates lesser combustion heat and allows the tip and electrode to stay hotter. This ensures that any deposit accumulation is burned off and isn't allowed to stay for long.

2. Cold Spark Plug:

For high-performance engines that run hot by default, using a hot spark plug will cause pre-ignition. In extreme cases, it can also lead to the tip melting off. In such cases, a cold spark plug is used. Here the ceramic insulation area is higher and this it will

dissipate more heat. But on the flipside, it is prone to greater deposit accumulation. Be sure to follow your instruction manual and use the correct type of plug recommended for your engine for optimum performance.

Based on Material Used

Spark Plugs are further classified based on the material used on the ends of the electrodes.

They are of 4 types:

1. Copper- Nickel Type:

These are the most basic types of spark plugs. Here the center electrode is made of a copper-nickel alloy as copper on its own is very weak and will melt off due to engine heat. Nickel is added to strengthen the plug but even then these are the weakest types available in the market. They are also required to be made with a larger diameter and hence require more voltage for operation.

2. Single Platinum Type:

These plugs have a small platinum disc on the tip of the center electrode. This platinum tip is exponentially stronger than a copper-nickel coating making this type of plug last long as well. They are also less prone to debris build up.

3. Double Platinum Type:

These plugs have platinum tips on both the center electrode and the side electrode. They spark up twice in the combustion cycle, once before the combustion and once during the exhaust stroke. The second spark is wasted and so this spark plug can only be used if your vehicle is equipped with a waste spark ignition type distributor.

4. Iridium Type:

These are the best spark plugs available in the market. Here the tip of the center electrode is made of Iridium which is the

strongest out of nickel, copper, and platinum. Hence, they are the least prone to deposits and damage. They also have a small sized electrode which requires less voltage for operation as well. Iridium plugs are much more expensive than the other types but then again you pay for what you get.

State the common ignition troubles and its remedies

COMMON IGNITION PROBLEMS

1

FAULTY IGNITION COIL, SPARK PLUG, OR SPARK PLUG WIRES

An ignition issue can be caused by a faulty or failing ignition coil, spark plug, or spark plug wire set. These critical components of your ignition system keep your engine running smoothly. If they have a problem, you'll notice a rough ride, engine misfires, and possibly decreased gas mileage, along with in most cars, a Check Engine Light (CEL) for a misfire.

Often times, replacing the failed or failing part will correct this issue.

Ignition coils and wire sets are fairly straightforward to replace. However, some applications will require removal of major components such as the upper intake plenum manifold. Reference a repair guide for more specific information for your vehicle.

Spark plugs may require a bit more attention on some vehicles. Some can be very easy to get to and replace, where other ones are a long, complex job depending on their location. We have

a [guide on replacing spark plugs](#). Some spark plugs need to be gapped and have anti-seize applied before installing and some do not. Check the spark plug manufacturer's requirements.

Spark plugs should always be installed with a spark plug socket and tightened to the proper torque. If you need a torque wrench.

2

CRANK POSITION SENSOR FAILURE

Any modern ignition system that doesn't use a distributor has to have a method at which to determine the precise moment to fire the ignition coils. To do this, a crank position sensor is used, which is essentially a magnetic trigger. At the precise moment in revolution, the sensor picks up a trigger point in the rotating crank, and sends signal. When this sensor fails, this signal is lost. Sometimes, it the part fails completely and you have either a dead vehicle on the road, or a no-start situation. Other times, the problem can be intermittent, leading to misfires, or stalling issues. In most cases, when this occurs, the vehicles engine computer will pick up a code for crank position sensors.

3

CAM POSITION SENSOR

Like it's cousin, the crank position sensor, a cam position sensor does the same thing on the engine's camshafts, or multiple camshafts. These devices read the position of the cam in respect to ignition timing, to either advance (make the spark come earlier) or retard (make the spark come later) in the stroke.

When a cam position sensor goes awry, you can experience much of the same issues – misfires, lack of power, poor gas mileage, or a no-run / no-start situation. Like most sensors, it's also picked up by the vehicles engine computer, so if there's a fault, an engine code will pick it up.

4

DISTRIBUTOR PICK-UP COIL / HALL EFFECT SENSOR

Very similar to a crank position sensor, in distributor-style ignition systems that do not use breaker points, each distributor has a pick-up coil, or hall effect sensor (same thing) that reads a cog wheel inside the distributor to accurately pick up and tell the precise moment when to send a signal to the coil to fire.

When a pick up coil goes out, you generally have a no-start situation. Many people often think this is the ignition coil, but often times, the pick-up coil is the culprit. Changing these coils can be difficult, because often, the distributor must be completely removed to gain access to it.

5

IGNITION MODULE

Many vehicles made in the last 10 years no longer use a proper Ignition Module, and instead house its function either in each individual coil, or in the vehicles onboard computer. Ignition Modules were the standard for many electronic ignition systems from the late 70's all the way through the early 2000's. Many foreign vehicles refer to the unit as a power output stage control, or ignition control unit, but they are all the same thing.

These devices help process the signal from a crank position sensor or pick-up coil in a distributor system and distribute the signal of when the coil should fire. When they go out, you can have a misfire, coil packs not functioning properly, or a no-run / no-start situation.

Description of the conventional suspension system for Rear and Front axle

In this type, wheels are mounted on

the two sides of the axle. Leaf spring or coil spring is mounted in between the chassis frame and axle. One end of the leaf spring is attached rigidly usually the front, and the other end is attached through a shackle as movable. The vibration is absorbed by the compression and expansion of leaf spring while travelling over a road with bump and pit. Two ends of the master leaf are connected with the kingpin and knuckle, so that vibration transferred from one side to

another. These types of suspension systems are mostly used in rear wheels alone.

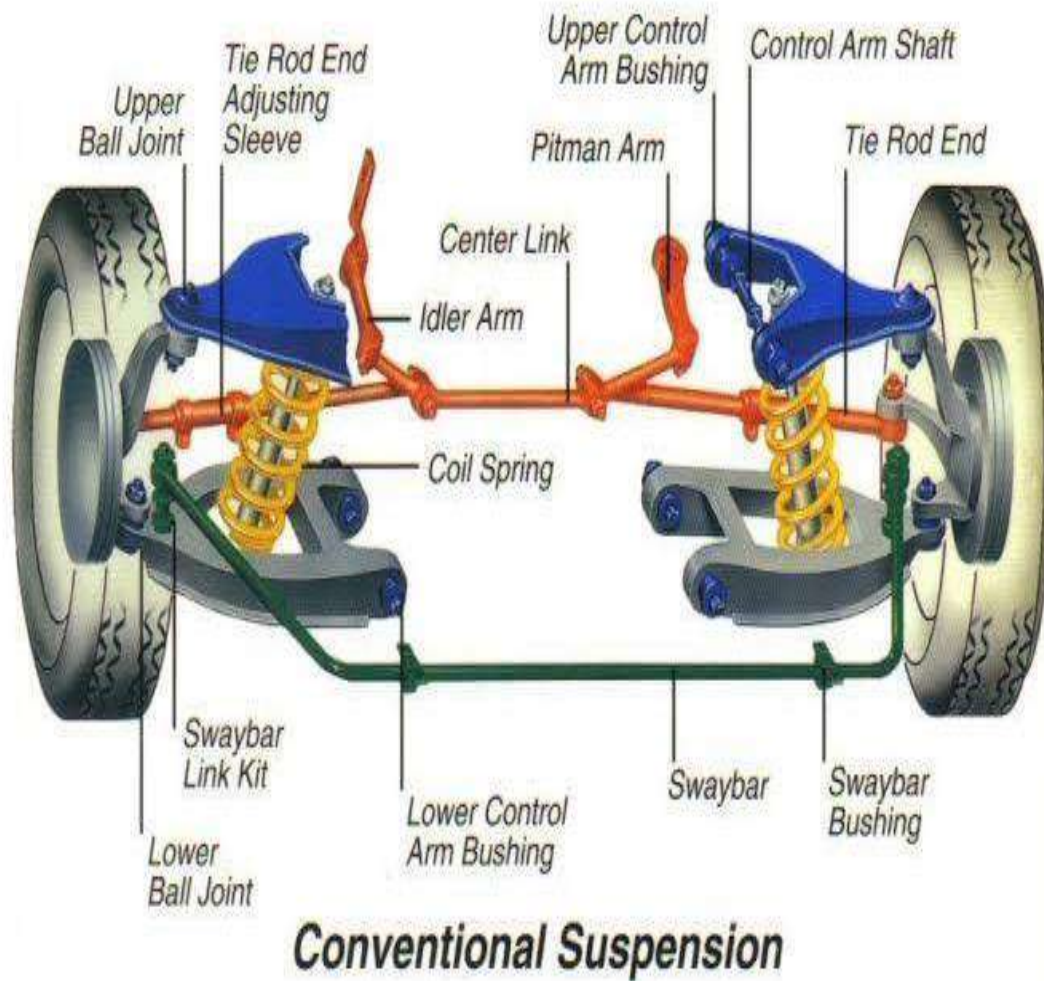

Advantages

1. Simple in design
2. Low cost
3. Less number of components
4. Less maintenance

Disadvantages

1. Road shocks from one wheel is transmitted to another wheel. If the road is irregular, the whole vehicle leans on one side.

2. As both the wheels do not get up or down simultaneously, so they will rotate in different positions.

Note Due to the gyroscopic effect during turning, wheel wobble or wheel shimmy takes place in a wheel. This is a very dangerous problem.

Description of independent suspension system used in cars (coil spring and tensionbars)

In this type of suspension, each front wheel is independently supported by a coil, torsion bar, or leaf spring. Most of the passenger cars now use the independent front suspension in which the coil spring system is the most common.

Types of Independent Front Suspension

1. Twin I-Beam Suspension System

Different types of front suspension, besides coil spring type, are also in use. The twin I-beam construction is another type, used on some models of Ford trucks. Each front wheel is supported at the end by a separate I beam.

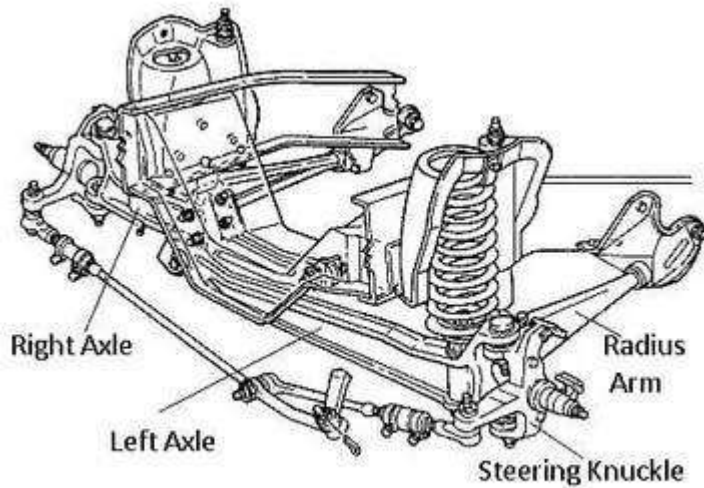

Twin I-Beam Front Suspension

The ends of the I-beams are attached to the frame by pivots. The wheel ends of the two I-beams are attached to the frame by radius arms, which prevent backward or forward movement of the wheels. This type of suspension provides more flexibility.

2. Single I-Beam Front Suspension System

Single I-beam front suspension is employed in larger vehicles. The I-beam has a hole in each end through which a kingpin is assembled to hold the steering knuckle in place. Each end of the I-beam is supported by a leaf spring.

3. Independent Front End Suspension Using Torsion Bar

This type of suspension system, a steel rod, known as a torsion bar, act as a spring to hold the upper and lower control arms parallel under load. The front end of the rod is of hexagonal shape to fit tightly into an opening in the lower control arm.

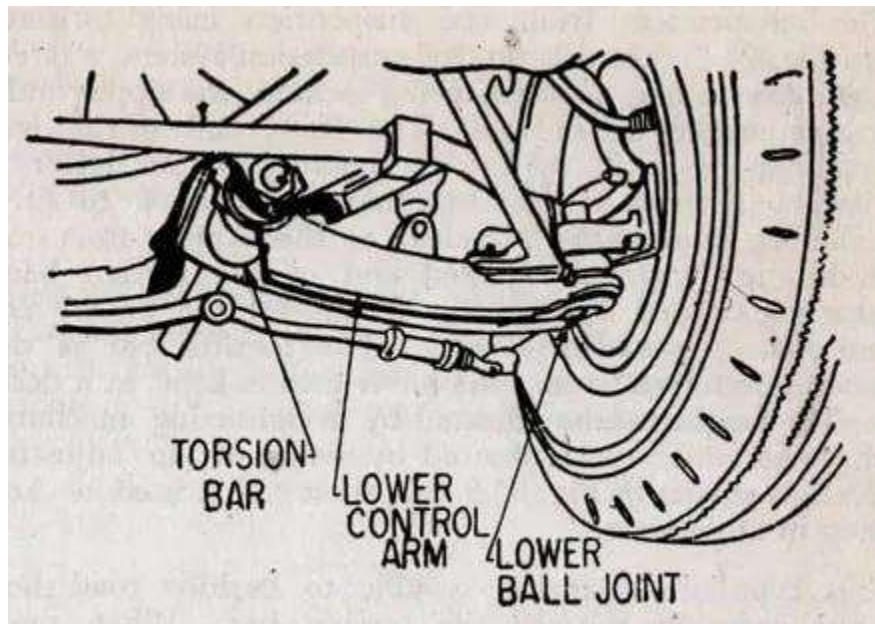

Its rear reaction is also the hexagonal shape to fit tightly into an opening in an anchor attached to the frame cross member. A seal hides the hexagonally shaped end of the torsion bar.

The torsion bar gets twisted due to the forces on the wheel assembly outer end of the lower control arm. The torsion bar is designed to balance these forces so that the lower arm is kept at a designated height.

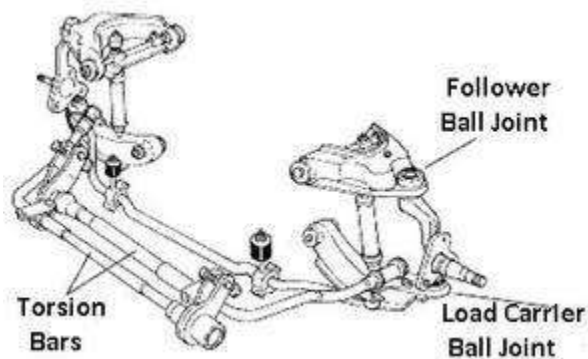

The height can be adjusted by a tightening mechanism at the anchor end which twists the rod by means of an adjusting bolt and swivel. A strut rod is used to keep the suspension in alignment.

This suspension is able to protect road shock causing the lower arm to twist the torsion bar. When the wheels are no longer under stress, the arm returns to normal.

4. Parallelogram Type Independent Front Suspension

The figure shows the simplified diagrams of the independent front suspensions using a coil, torsion bar and leaf spring. Basically, the system is known as parallelogram type independent front suspension. It consists of an upper and lower link connected by **stub axle** carrier.

In general, the lower link is larger than the upper and they may not be parallel. This arrangement maintains the track width as the wheels rise and fall and so minimize tyre wear caused by the wheel scrubbing sideways.

5. Struck and Link Type Suspension System

This type of suspension system is unusually for integral body construction because the loading points are widely spaced. The normal top link is replaced by a flexible, mounting and the telescopic damper acts as the kingpin. This suspension system known as the Mac Pherson System has slight rolling action and absorbs shocks easily.

6. Trailing Arm Independent Front Suspension

Trailing arm independent front suspension maintains constant track and wheel attitude with a slight change in wheelbase and caster angle. A coil spring is attached to the trailing arm which itself is attached to the shaft carrying the wheel hub. When the wheel moves up and down, it winds and unwinds the spring. A torsion bar has also been used in certain designs in place of the coil springs.

7. Sliding Types Suspension System

In this type suspension system, the stub axle can move up and down as well as rotate in the frame members. Track, wheel attitude and wheelbase remain unchanged throughout the rise and fall of the wheel.

8. Vertical Guide Suspension System

In the vertical guide suspension system, the kingpin is attached directly to the cross member of the frame. It can slide up and down, thus compressing and expanding springs.

Coil Spring Front Suspension.

There are 3 types of coil spring front suspension.

1. In the first type, the coil spring is located between the upper and lower control arms. The lower control arm has one point of attachment to the car frame.

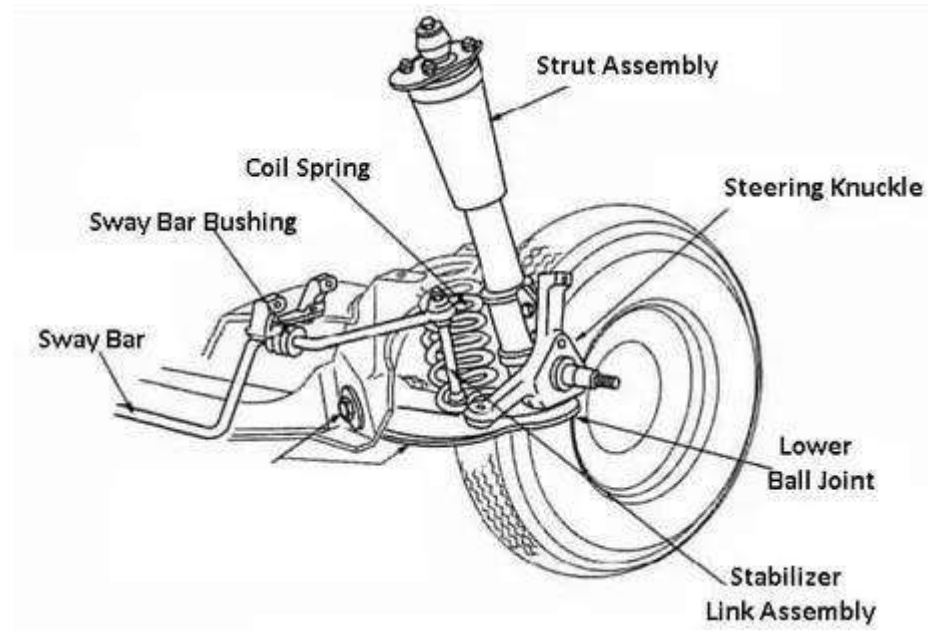

2. In the second type, the coil spring is located between the upper and lower control arms. The lower control arms have two points to the attachment to the car frame.

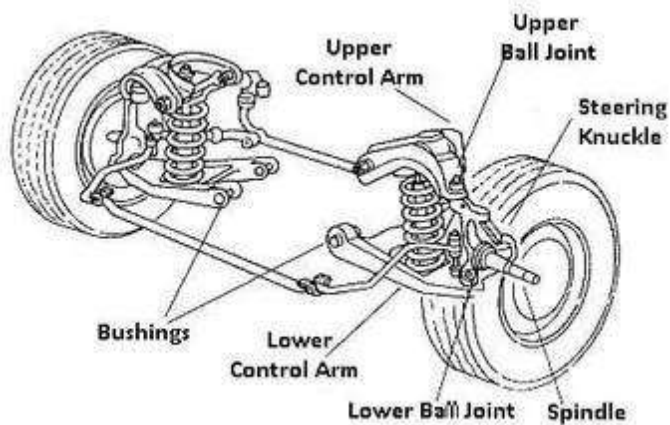

3. In the third type, the coil spring is between the upper control arm and spring tower or housing that is part of front end sheet metal work.

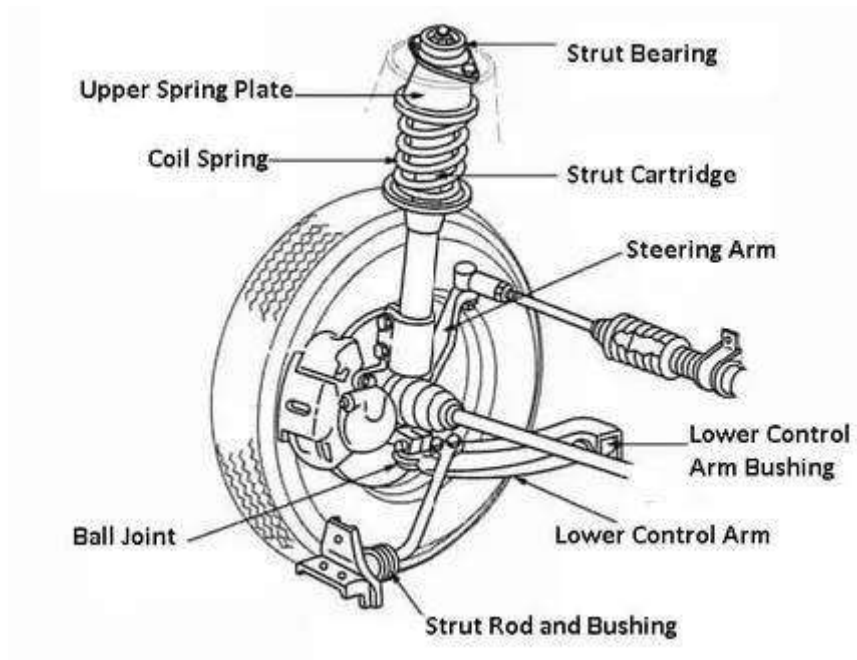

2. Rear End Suspension System

Following are three types of rear-end suspensions generally found in vehicles.

1. Longitudinal leaf spring rear end suspension
2. Transverse leaf spring rear end suspension
3. Coil spring rear end suspension

Longitudinal and Transverse Leaf Spring Rear End Suspension

Longitudinal leaf spring and coil spring rear end suspensions are widely used in modern vehicles. Transverse leaf spring rear end suspension is used in conjunction with the Hotchkiss drive, the leaf springs must be made strong and resilient enough to transmit the driving thrust and torque to resist sideways, in addition, to hold the spring weight of the body.

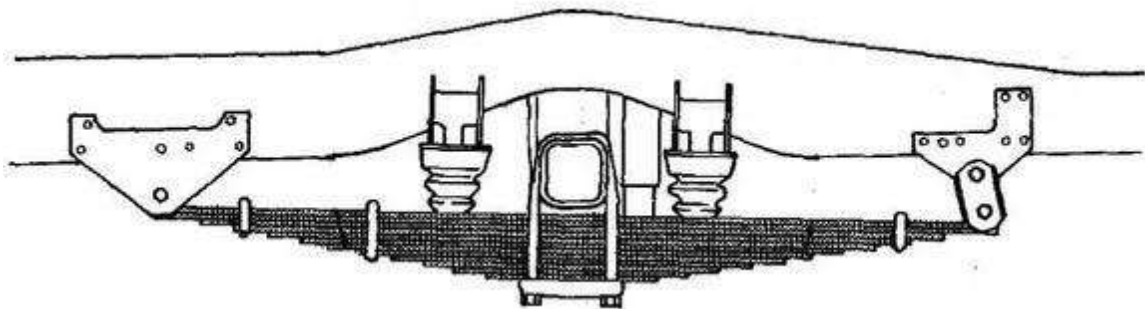

The spring weight is kept as less as possible, in order to improve the side of the vehicle. Because the springs do not generally support the wheels, rims, tyres, brakes and rear axles, the weight of these parts is called the spring weight. The spring is clamped the rear-axle housing by U-bolts, its every end is pivoted to the frame, by means of eyes formed in the ends of the longest leaf.

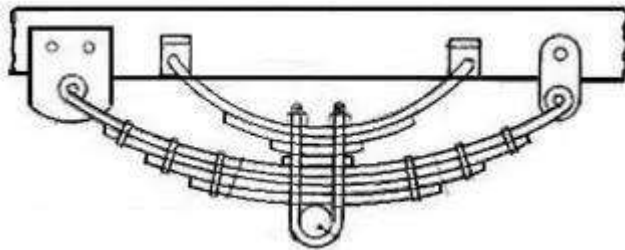

One end of the long leaf is secured to the front hanger by a bolt and the other end to the rear hanger by spring shackles. Both the hangers are bolted to the frame. The spring elongates in compression and shortens in expansion. This change in length of the spring is compensated by a shackle.

At the middle position of the spring length, the rebound clips are placed. They are loose enough to permit the leaves to slide on the other, and yet tight enough to permit the leaves together when the spring rebounds. The spring eyes are usually provided with bushings or some anti-friction material, such as bronze or rubber.

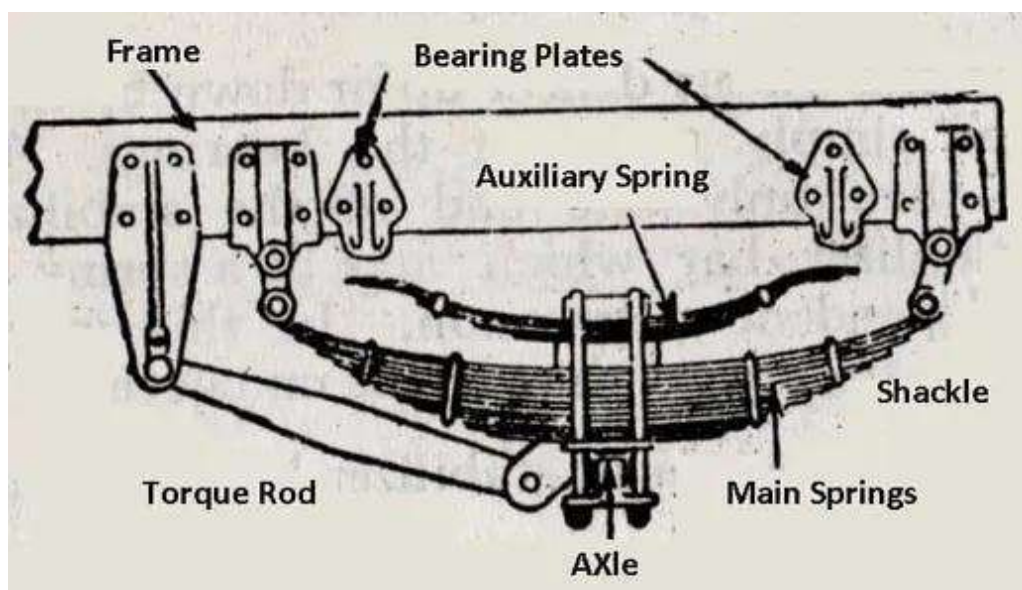

The figure shows a heavy-duty truck rear end suspension with leaf type auxiliary springs and torque rods. This type of suspension is used in truck intended for more severe operations and with rear axle loading exceeding 10000 kg. The figure shows rear-end suspension of a car with Hotchkiss drive.

Coil Spring Rear End Suspension

The figure shows coil spring rear end suspension. This type of suspension is always used in conjunction with torque tube, torque reaction link, or torque rod drive. Therefore the coil springs are not subjected to driving thrust or twist.

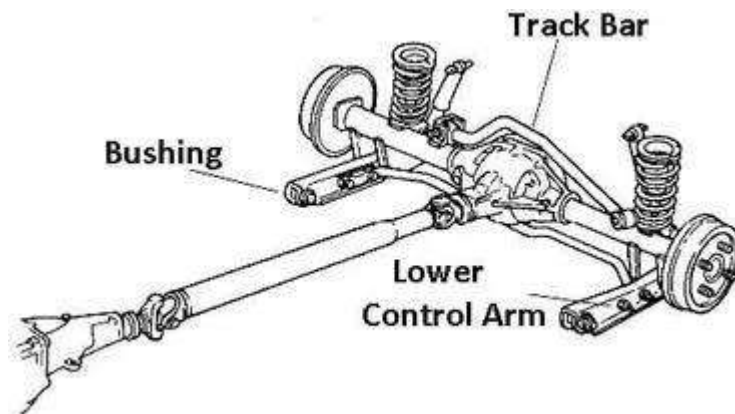

Stabilizers and radius rods are also used which relieve the coil springs of all stresses except those acting in a vertical direction. The stabilizer prevents excessive roll or sideways when the car is concerning.

The radius rod keeps the rear axle and frame in lateral alignment. The coil springs are seated in pan-shaped brackets spring seats attached to the rear axle.

De-Dion and Independent Type Coil Spring Rear End Suspensions

The figure shows De-Dion and independent type coil spring rear end suspensions. At (A), the rigid De-Dion tube is located longitudinally by two parallel links and laterally by a watt linkage. The tube maintains the track at a constant width.

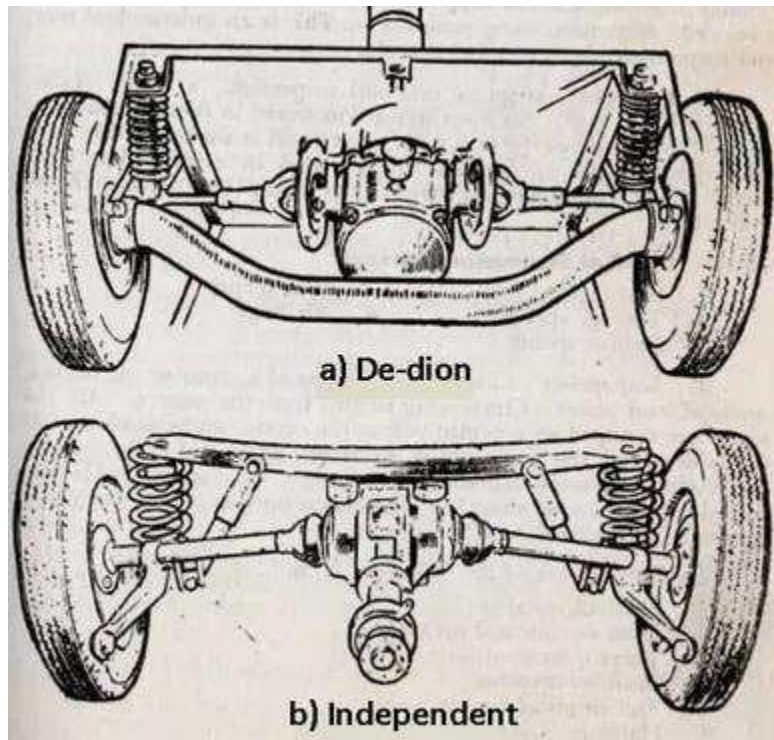

It is to be noted that De-Dion suspension is not an independent suspension because a tubular axle connects and supports both the wheels. At (B) is shown a rear-end suspension using the radius arm. This is an independent rear end suspension.

In traverse leaf spring rear end suspension, a single transverse spring is used. Such springs are mounted in an inverted position parallel to and above the rear axle. Each end is shaken to the axle.

The transverse rear springs are always used in combination with torque-tube drive, and hence they do not carry the driving thrust and torque.

Constructional features and working of a telescopic shock absorber

Function of shock absorber:

The shock absorber is a part of suspension system used as springing device to compromise between flexibility and stiffness. It absorbs the energy of shock converted into the vertical movement of the axle by providing damping and dissipating the same into heat.

Purpose of shock absorber:

- (i) To control the vibrations on springs.
- (ii) To provide a comfortable ride.
- (iii) To act flexible and to be rigid enough.
- (iv) To resist the unnecessary motion of the spring.

Construction of Shock Absorber :

The upper eye of the telescopic shock absorber is attached to the axle and the lower eye is attached to the chassis frame as shown in Figure 4.55. A two-way valve V1 is connected to a rod. Another one two-way valve V2 is connected to the lower end of the cylinder. The fluid occupies in the space between above and below the valve V1 and also the annular space between the cylinder and tube. A gland is provided on the head. Fluid scrapped out by the rod is brought down into the annular space through the inclined passage.

Working of Shock Absorber :

When the vehicle comes across a bump, the lower eye will move up. So, the fluid follows from the lower side of the valve V1 to the upper side. Due to less volume of the space above valve V1 than the volume of the rod, the pressure is exerted on valve V2. Thus, the damping force is produced by this pressure of the fluid. The fluid will flow from the upper side of the valve V1 to the lower side when the lower eye moves down and from the lower side of the valve V2 to its upper side.

When a car absorbs shocks from the road surface, the suspension springs will compress and expand because the spring has the characteristic of continuing to oscillate for a long time of oscillation to stop. So, a riding comfort will be poor even the damp oscillation is supplied. Shock absorbers provide better road-holding characteristics and improved steering stability to tires.

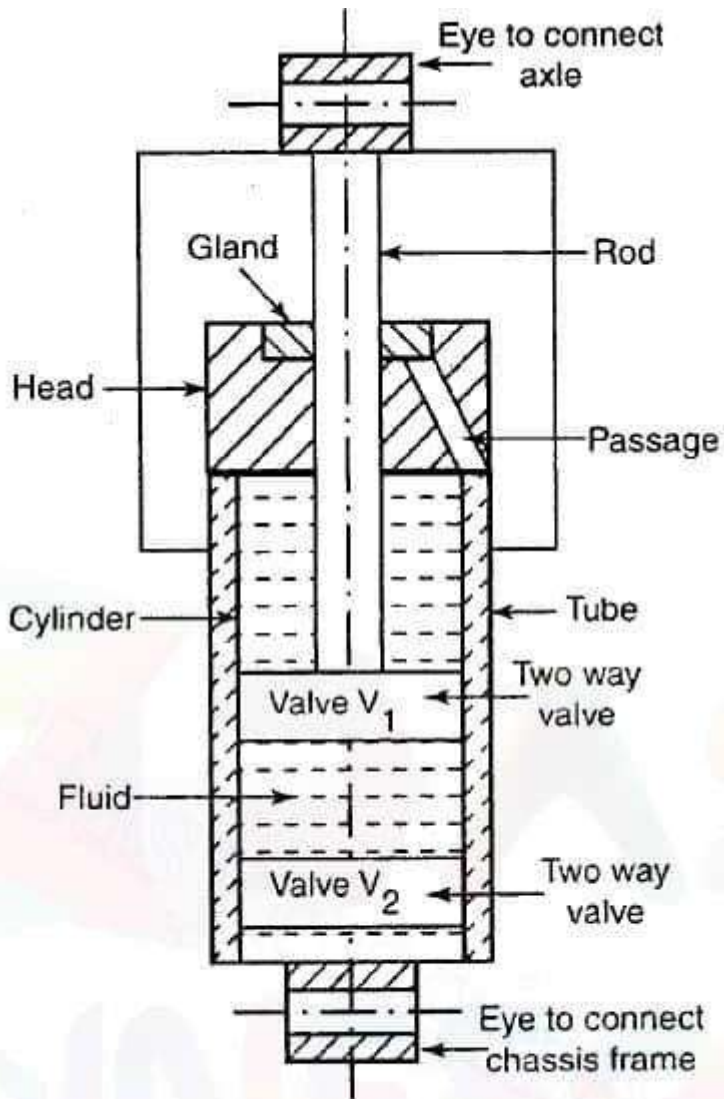

Figure 4.55 Telescopic shock absorber

telesco

pic shock absorber diagram

The stronger is the damping force, the more will be the oscillations of the body. But, the shock from the damping effect becomes greater than the strength of the stronger damping force. The damping force varies with the speed of the piston.

Types of shock absorbers:

1. Mechanical shock absorber (friction type)
2. Hydraulic shock absorber.

Again the hydraulic shock absorbers are further divided into various types.

1. Van type
2. Piston type
 - a. Single-acting
 - b. Double acting
3. Telescopic type.



Shock absorber

Advantages of telescopic shock absorber:

1. A large amount of energy is dissipated due to a large volume of fluid displaced without causing a high-temperature rise.
2. There is no wear development in the damper with the absence of connecting arm pivots.
3. The applied force is increased when compared to the indirect-acting type. Low fluid pressure due to the fairly large piston area occurs with reduced levers.
4. The leakage is very less due to lower pressure and absence of the rotating shaft entering the reservoir.
5. The cost is less than springs.
6. No need of topping up is necessary for most of the telescopic dampers.

4.0 COOLING AND LUBRICATION:

Engine cooling: Need and classification

The Engine cooling system is one of the necessary thing that is present in the Internal Combustion Engine to reduce the temperature of the components inside the engine. It also helps to reduce the wear out of the component and provide smooth functioning and long life of the components.

What are the Types of Engine Cooling Systems?

Generally, there are two types of the cooling system, and those are:

- Air Cooling System
- Water Cooling System

Air Cooling system:

In this system, the heat from the engine is directly dissipated to the atmosphere.

The Basic Principle of this type of system is to allow a flow of current through the parts from which heat is to be dissipated, which depends upon the surface area of metal in contact rate of flow of air, a temperature difference between hot surface and air.

And Surface area of metal will be increased by providing the fins around the cylinder which is made of copper or steel.

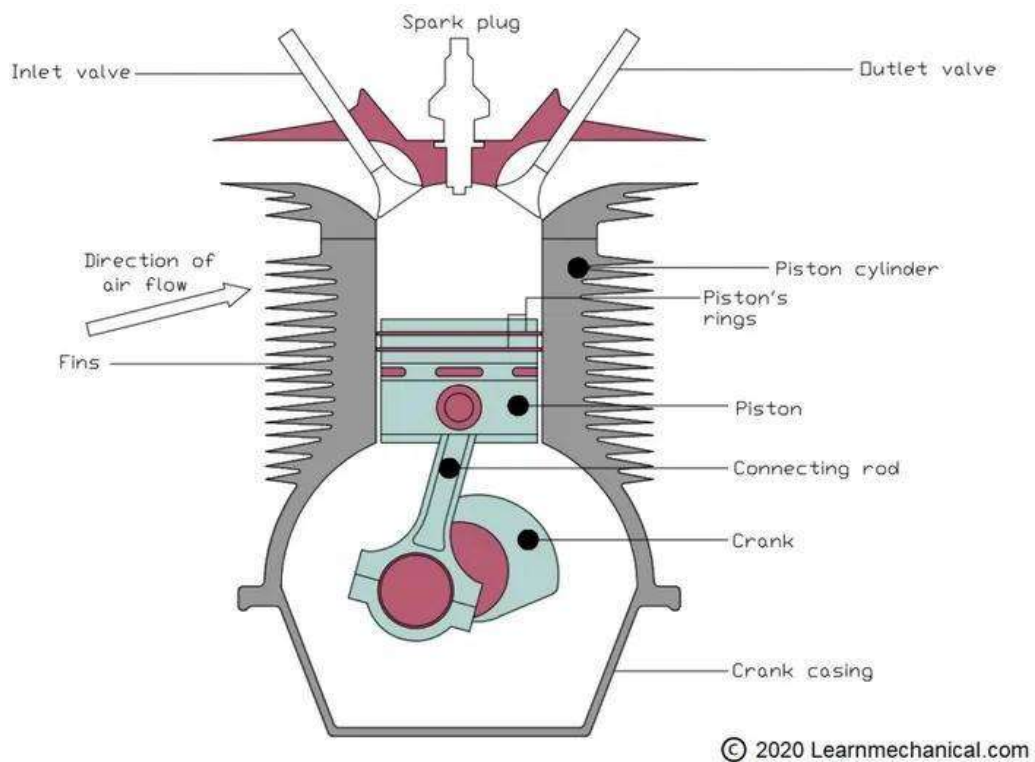

Air-Cooling System

Advantages of Air Cooling System:

These are some advantages of using Air Cooling System:

- Light in weight
- No antifreeze is required
- This system can be used where water scarcity is there
- Simple in design
- Require less space
- No tapping up of water, etc.

Disadvantages of Air Cooling System:

Air Cooling System also has some disadvantages, and those are:

- More noise in operation.
- The coefficient of heat transfer of air is less, hence less efficient in working.

Examples of Air Cooled Engine:

- It is used in scooters, motorcycles, and tractor.

Water Cooling System:

This type is the most commonly used type of system.

In this system dissipation of heat is done by the circulation of water through the jackets around the cylinder and passes this hot water through the radiator where air absorbs heat from the water.

There are two types of water cooling system.

1. Thermosyphon
2. Pump circulation system

Thermosyphon System:

The pump is not fitted in this system.

Circulation of water is done due to the difference in densities between hot and cold water.

However, in this cooling system, the rate of cooling is low. Nowadays its usage is limited because we need to maintain the water to a certain level. It is simple in construction and cheap.

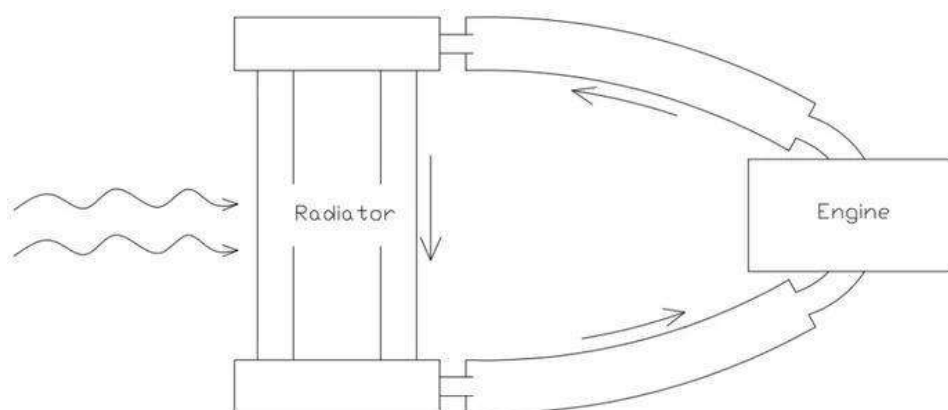

© 2020 Learnmechanical.com

diagram of Thermosyphon System

Working of Thermosyphon System:

The thermosyphon cooling system operates on the principle of natural convection.

Thermo-syphon water cooling system is based on the fact that water becomes light on heating and,

The top and bottom of the radiator are connected to the top and bottom of the cylinder water jacket respectively with the help of pipes.

The [radiator](#) is cooled by causing air to flow over it. Airflow is achieved by vehicle motion or a fan provided.

The heated water inside the cylinder water jacket becomes light and moves out of the upper connection pipe into the radiator and travels down from the upper tank to the lower tank, and rejecting heat as it travels.

This cooled water from the lower tank is passed into the cylinder water jacket and hence circulated again for the process.

The limitation of this system is that this cooling depends only on temperature and is independent of engine speed.

Pump Circulation System:

In this cooling system, the circulation of water is done by providing a [centrifugal pump](#).

Due to this pump, the rate of flow of water is more.

Here radiator may be fitted at any place convenient to the designer.

The pump is driven by a belt from a crankshaft.

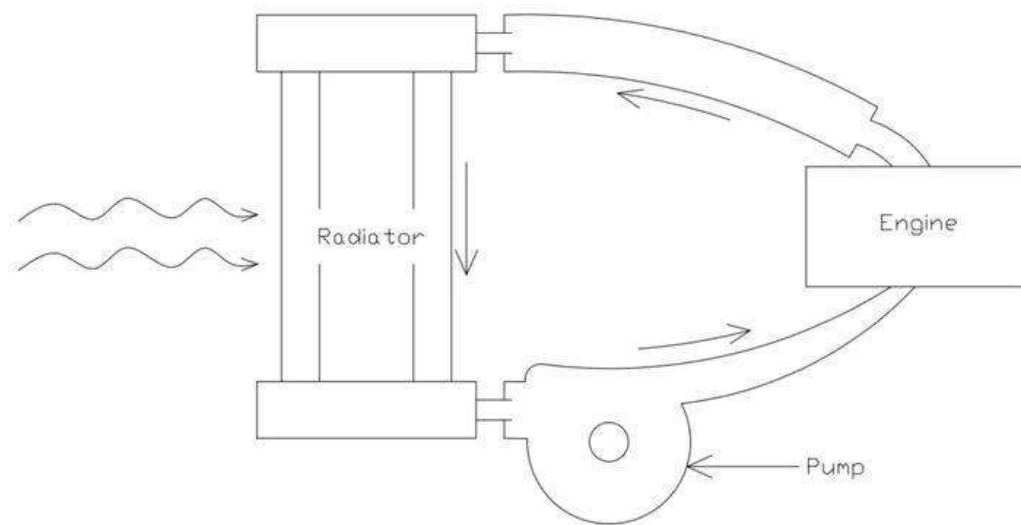

© 2020 Learnmechanical.com

Diagram of Pump Circulation Cooling System

Working of Pump Circulation System:

In this system, the direction of cooling water flow is upward from the cylinder head to the top tank of the radiator, then down through the radiator core to the bottom tank.

From the bottom tank, it moves through the lower radiator hose to the cylinder block water jackets by the help of the water pump, which circulates the water.

Water enters the engine at the center of the inlet side of the pump.

The circulating pump is driven by a belt from the crankshaft.

As engine speed increases, the flow of coolant increases.

Parts of the Water Cooling System:

These are some major parts of water cooling system:

- Radiator
- Water Pump
- Fan
- Water Jackets around the Cylinders

- Hose Pipe
- Thermostat Valve

Radiator:

Radiator is a heat exchanger used in a IC Engine, it consist of two tanks [oner is called upper tank, and other one is lower tank] and buch of tubes connected to the both tanks.

The upper tank is connected with the exit channel of engine jackets via hose pipe, and bottom tank is connected with the entry channel of the cooling jacket via a water pump.

The hot water comes from the engine cylinder filled the upper tank, from the upper tank with the help of radiator tubes the hot water comes to the lower tank. By the time of following through the tubes the hot water is cooled by the flow of atmospheric air or sometimes a fan is fitted at the backside of the radiator.

In general radiators are made of these metarials:

- Cast iron
- Mild steel
- Stainless steel
- Aluminium
- Copper
- Brass

Water Pump:

Water pump is used for the force circulation of water inside the engine. The water pump is driven by a belt which is connected to the crankshaft.

Fan:

Fan is used for blowing the air through the radiator tubes. It is driven by the same belt which drive the pump.

Water Jackets:

It is fitted outside the engine cylinder. These jackets are used for transferring the heat from the engine cylinder.

Hose Pipe:

It is the pipe connected between the engine's water jackets and radiator.

Thermostat Valve:

The function of this valve is to restrict the flow of water from the engine to the radiator. This valve design as when the water temperature inside the engine cylinder exceeds a certain value (Generally 70-degree centigrade) then the valve allows the flow of water, if the temperature of the water inside the cylinder is below 70-degree centigrade then the valve restrict the flow of water.

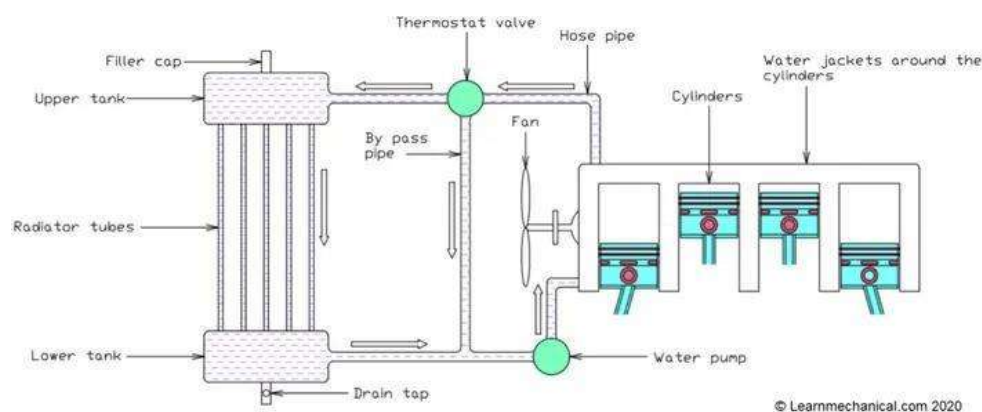

Parts of Water Cooling System

Advantages of Water Cooling System:

These are some advantages of Water Cooling System:

- In these types of cooling, we see a high heat transfer rate.
- This type of cooling system is used where the size or power of the engine is more.
- Thermal Conductivity is more
- Water is easily available

- Liquid has a high enthalpy of vapourization so that the efficiency of water cooling is more.

Disadvantages of Water Cooling System:

The disadvantages of Water Cooling System is mentioned below:

- Some time corrosion occurs inside the radiator or pipe or storage.
- Due to scaling heat transfer rate is goes down after the long run, so it needs regular cleaning and maintenance.

Examples of Water Cooled Engine:

- All the modern engines (Cars, Bus, Trucks, etc.) are nowadays use this type of cooling system.

Necessity of Cooling System:

The need of cooling system in an **IC Engine** because of the following reason:

- During the operation of an engine, the temperature inside the engine can go up to 2500 degree centigrade (Source: How Stuff Works), which is above the melting point of the components used to make the engine. So we need to use the cooling system to dissipate the heat as much as possible.
- As we know, we also need lubrication system to the proper functioning of the engine, but due to the high heat, the property of lubricating oil can be changed. That result seized of the engine. So to avoid that we need to use a cooling system.
- Sometimes due to the enormous heat, thermal stress is built-up inside the engine, so to minimize the stress we need to keep the engine temperature as low as possible.

Describe defects of cooling and their remedial measures

External Leakage

1. Loose hose clips.
2. Defective rubber hose.
3. Damaged radiator seams.
4. Excessive wear in the water pump.
5. Loose core plugs.

6. Damaged gaskets.
7. Leaks in the heater connection or plugs.
8. Leak at the water temperature gauge plugs.

Internal Leakage

1. Defective cylinder head gasket.
2. Cracked cylinder wall.
3. Loose cylinder head bolt.

Water Loss

1. Boiling.
2. External or internal leakage.
3. Restricted radiator or inoperative thermostat.

Poor Circulation

1. Restricted in the system.
2. Insufficient coolant.
3. Inoperative water pump.
4. Loose fan belt.
5. Inoperative thermostat.

Corrosion

1. Excessive impurity in the water.
2. Infrequent flushing and draining of the system.
3. Incorrect anti-freeze mixture.

Overheating

1. Poor circulation due to any reason.
2. Dirty oil and sludge in the system.
3. Radiator fins choked.
4. Incorrect [ignition system](#).
5. Incorrect valve timing.
6. Low oil level.
7. Tight engine.
8. Engine oil too thick.
9. Clogged exhaust system.
10. [Dragging brakes](#).

Overcooling

1. Defective thermostat.
2. Inaccurate temperature gauge.

Cooling System:

If the middle combustion of the cylinder is not controlled, it will be impossible to run the engine. Receives up to 40% of the heat and helps the [engine](#) to run normally.

There are two main types of calling method used to keep the engine cool.

Such as

1. [method](#) of cooling with the help of air
2. method of cooling with the help of water.

Cooling method with the help of air:

Air cooling engines are cars that use air to cool their engines. Such as motorcycles, small engines, airplanes, etc.

Cooling method with the help of water:

The water cooling system is used in cars that use water to cool the engine. The water cooling system is used in most of the cars in the world.

1. Radiator
2. Radiator cap
3. Overflow line
4. [Water pump](#)
5. Thermostat valve
6. Reserve bottle
7. Bypass line
8. Hose pipe water
9. Jacket return line

10. Cylinder head

11. Crankcase

Some important components of cooling system are discussed

Radiator:



Radiator

It contains about 10 liters to 13 liters of water. This water should be completely clean. For example, rivers, rain, or mineral water should be given. tubewell water cannot be given because it contains a lot of iron. Tubewell water destroys the radiator core or tubes in a short time. Never drive without opening the radiator cap. The opening pressure of this cap is 0.5 to 0.9 bar.

Thermostat valve:

It works a lot like a switch gate, meaning that the engineer controls the flow of water according to the temperature of the water flowing through the water jacket. If it is not allowed to drive the car, the life of the engine will be reduced. It starts at 74 degrees Celsius and opens completely at 90 degrees.

Cooling System Problems And Solutions

S.N	Problems	Problems	Solutions
01.	The engine is overheated.	<p>First of all you have to test the cooling method.</p> <p>Radiators are dirty or the tubes are jammed with dirt.</p> <p>The water jacket is jammed with rusty dirt.</p> <p>The fan is broken or not working.</p> <p>Loosen or loosen the pump</p>	<p>Cleaning or repair.</p> <p>Need to be cleaned.</p> <p>Need to change.</p> <p>Change or tighten.</p> <p>Need to clean or change.</p> <p>Clear or change.</p> <p>Oil should be given as required.</p>

		<p>belt.</p> <p>Hose pipe closed or bad.</p> <p>The thermostat valve is not working properly.</p> <p>The impeller or shaft of the water pump is broken.</p> <p>The air cleaner is dirty or obstructed.</p> <p>There is more or less engine oil.</p> <p>If the injector or nozzle is damaged.</p> <p>If the timing of the fuel pump is not correct.</p> <p>If the cylinder gas kit leaks.</p> <p>If the valve timing is not correct.</p>	<p>Repair or replacement.</p> <p>The timing needs to be right</p> <p>The head bolts should be tightened well.</p> <p>And gasket timing must be correct.</p>
02.	Leakage and noise are created at the base of the water pump.	<p>The seal on the water pump may be damaged.</p> <p>The shaft of the pump may break.</p> <p>The pump bearings may break.</p> <p>Puli has lost one line.</p>	<p>The seal needs to be changed.</p> <p>The shaft needs to be changed.</p> <p>The bearings need to be changed.</p> <p>Repair or replacement.</p> <p>Repair or replacement.</p>

03.	Water leakage or water is reduced.	<p>The radiator may have a top-down hole or a core or tube hole.</p> <p>Hose pipe holes or connections may be loose.</p> <p>Drain plug leaked or damaged.</p> <p>If the radiator cap is damaged or not.</p> <p>If the head gasket is bad.</p> <p>If the engine block is cracked.</p>	<p>The hole needs to be repaired or replaced.</p> <p>Need to change or tighten well.</p> <p>Need to repair or change.</p> <p>Need to change.</p> <p>Need to change.</p> <p>Need to repair or change.</p>
-----	------------------------------------	--	--

Describe the Function of lubrication

Function of lubrication :

Lubrication produces the following effects:

- (a) Reducing friction effect
- (b) Cooling effect
- (c) Sealing effect and
- (d) Cleaning effect.

(a) Reducing frictional effect:

The primary purpose of the lubrication is to reduce friction and wear between two rubbing surfaces. Two rubbing surfaces always produce friction. The continuous friction produce heat which causes wearing of parts and loss of power. In order to avoid friction, the contact of two sliding surfaces must be reduced as far as possible. This can be done by proper lubrication only. Lubrication forms an oil film between two moving

surfaces. Lubrication also reduces noise produced by the movement of two metal surfaces over each other.

(b) Cooling effect:

The heat, generated by piston, cylinder, and bearings is removed by lubrication to a great extent. Lubrication creates cooling effect on the engine parts.

(c) Sealing effect:

The lubricant enters into the gap between the cylinder liner, piston and piston rings. Thus, it prevents leakage of gases from the engine cylinder.

(d) Cleaning effect:

Lubrication keeps the engine clean by removing dirt or carbon from inside of the engine along with the oil.

[1] It should have a high viscosity index.

[2] It should have flash and fire points higher than the operating temperature of the machine.

[3] It should have high oiliness.

[4] The cloud and pour points of a good lubricant should always be lower than the operating temperature of the machine.

[5] The volatility of the lubricating oil should be low.

[6] It should deposit least amount of carbon during use.

[7] It should have higher aniline point.

[8] It should possess a higher resistance towards oxidation and corrosion.

[9] It should have good detergent quality.

Lubrication theory:

There are two theories in existence regarding the application of lubricants on a surface:

- (i) Fluid film theory and
- (ii) Boundary layer theory.

(i) Fluid film theory:

According to this theory, the lubricant is, supposed to act like mass of globules, rolling in between two surfaces. It produces a rolling effect, which reduces friction.

(ii) Boundary layer theory:

According to this theory, the lubricant is soaked in rubbing surfaces and forms oily surface over it. Thus the sliding surfaces are kept apart from each other, thereby reducing friction.

Describe the lubrication System of I.C. engine

various lubrication system used for IC engines are,

- (a) Mist lubrication system**
- (b) Wet sump lubrication system**
- (c) Dry sump lubrication system**

(a) Mist lubrication system:

- Used where crankcase lubrication is not suitable
- Generally adopted in two stroke petrol engine line scooter and motor cycle. It is the simplest form of lubricating system.
- It is the simplest form of lubricating system. It does not consist of any separate part like oil pump for the purpose of lubrication.
- In this system the lubricating oil is mixed into the fuel (petrol) while filling in the petrol tank of the vehicle in a specified ratio (ratio of fuel and lubricating oil is from 12:1 to 50:10 as per manufacturers specifications or recommendations.
- When the fuel goes into the crank chamber during the engine operation, the oil particles go deep into the bearing surfaces due to gravity and lubricate then. The piston rings, cylinder walls, piston pin etc. are lubricated in the

same way.

-If the engine is allowed to remain unused for a considerable time, the lubricating oil separates oil from petrol & leads to clogging (blocking) of passages in the carburettor, results in the engine starting trouble. This is the main disadvantage of this system.

-It causes heavy exhaust smoke due to burning of lubricating oil partially or fully

-Increase deposits on piston crown and exhaust ports which affect engine efficiency

-Corrosion of bearing surfaces due to acids formation

-thorough mixing can fetch effective lubrication

-Engine suffers insufficient lubrication during closed throttle i.e. vehicle moving down the hill.

(b) Wet sump lubrication system:

Bottom of the crankcase contains oil pan or sump from which the lubricating oil is pumped to various engine components by a pump. After lubrication, oil flows back to the sump by gravity. Three types of wet sump lubrication system,

(i) Splash system

(ii) Splash and pressure system

(iii) Pressure feed system

(i) Splash system:

-In this system of lubrication the lubricating oil is stored in an oil sump. A scoop or dipper is made in the lower part of the connecting rod. When the engine runs, the dipper dips in the oil once in every revolution of the crank shaft, the oil is splashed on the cylinder wall. Due to this action engine walls, piston ring, crank shaft bearings are lubricated.

-It is used for light duty engine

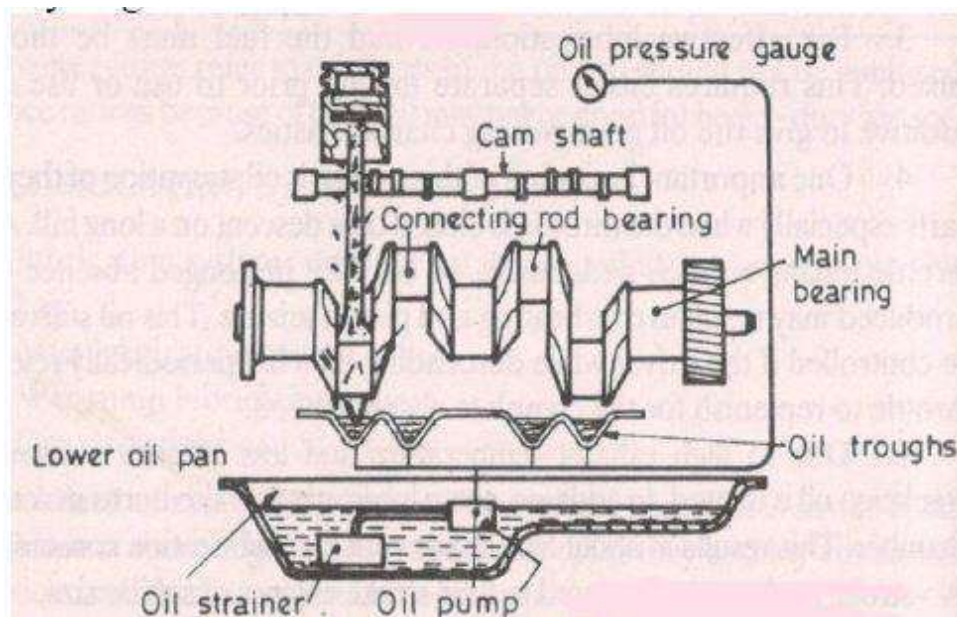

(ii) *Splash and pressure system:*

Lubricating oil is supplied under pressure to main, camshaft bearings and pipes which direct a stream of oil against the dippers on the big end of connecting rod bearing cup and thus crankpin bearings are lubricated by the splash or spray of oil thrown up by the dipper.

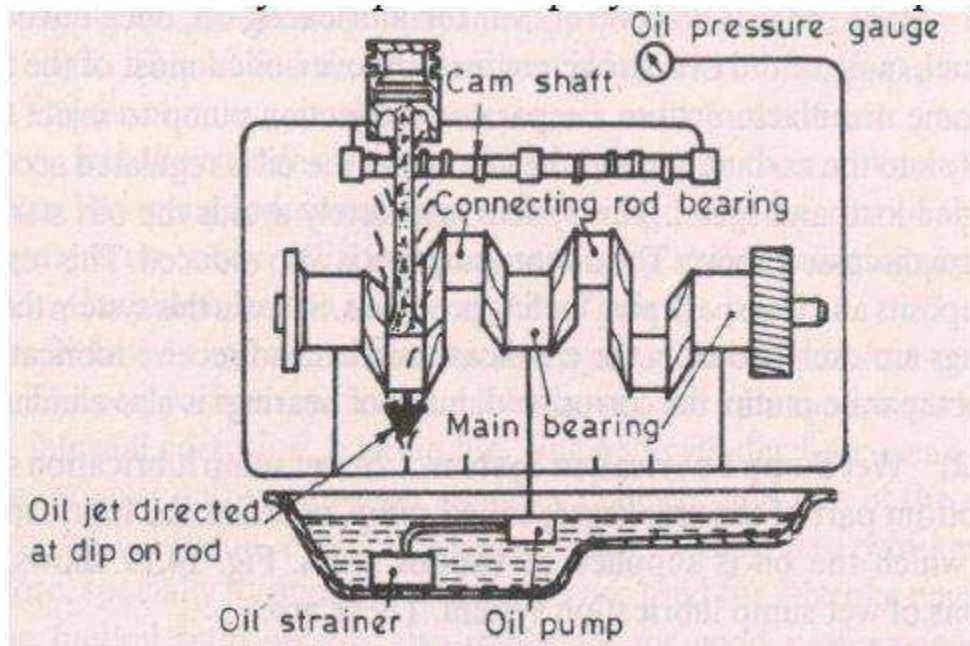

(iii) Pressure feed system:

In this system of lubrication, the engine parts are lubricated under pressure feed. The lubricating oil is stored in a separate tank (in case of dry sump system) or in the sump (in case of wet sump system), from where an oil pump (gear pump) delivers the oil to the main oil gallery at a pressure of 2-4 kg/cm² through an oil filter. The oil from the main gallery goes to main bearing, from where some of it falls back to the sump after lubricating the main bearing and some is splashed to lubricate the cylinder walls and remaining goes through a hole to the crank pin. From the crank pin the lubricating oil goes to the piston pin through a hole in the connecting rod, where it lubricates the piston rings. For lubricating cam shaft and gears the oil is led through a separate oil line from the oil gallery. The oil pressure gauge used in the system indicates the oil pressure in the system. Oil filter & strainer in the system clear off the oil from dust, metal particles and other harmful particles.

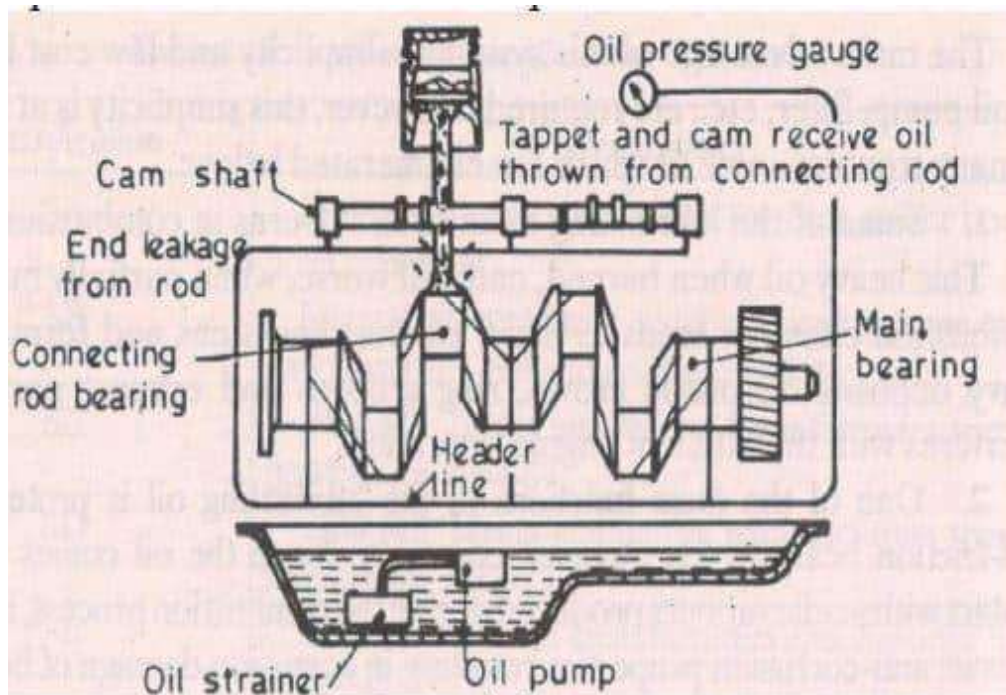

5.0 FUEL SYSTEM:

Describe Air fuel ratio

Air Fuel Ratio in Internal Combustion Engine

Internal Combustion Engine

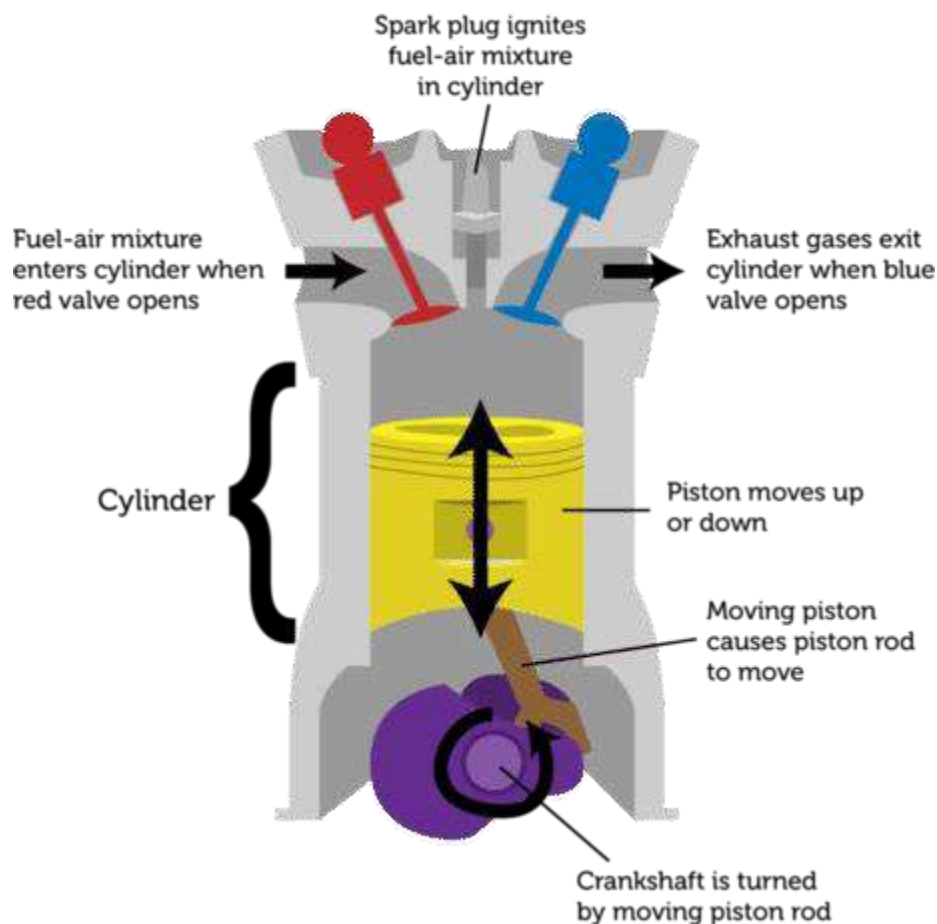

Higher compression ratio and larger piston bore in an engine produce higher power and torque. The higher compression in a combustion chamber makes the air and fuel particles compressed in larger density and in high pressure. Larger piston geometry (bore) will let more air passing through the combustion chamber. Both of these variables will create powerful explosion and burns fuel more efficiently. The

modification will generate fuel economy and will deliver peak performance. However, these modifications have its drawbacks too. High octane gas is needed to keep the engine running in good condition which is more expensive than regular unleaded gas. Using low octane will develop engine knock. Engine knocking happens when the air-fuel combustion doesn't happen at the exact time of spark ignition in the piston's stroke. Furthermore, larger explosion actually create more power and will make the engine runs hotter than normal. Larger piston bore also require more fuel to burn to compensate the larger air flow through combustion chamber [1].

As we known gasoline engines burn fuel to create motions. The reaction of mixture of fuel with oxygen in the air is cause from burning of fuel. This is called air-fuel ratio (AFR). AFR is the mass ratio of air to fuel present in an internal combustion engine. For gasoline engines, the stoichiometric, A/F ratio is 14.7:1, which means 14.7 parts of air to one part of fuel [2]. It depends on type of fuel. Different fuel gives different AFR. The AFR is necessary for controlling emission and performance-tuning reasons [3]. The mixture combust and produce the product of carbon dioxide, water and nitrogen [4]. The AFR calculation is based on Lambda Oxygen (O²) sensor in gasoline engine. The AFR are defined below [5]:

$$AFR = \frac{m_{air}}{m_{fuel}}$$

The AFR is related to mixture of air and fuel. The AFR is important measure for anti-pollution and performance tuning reasons. Furthermore, it is important to know the AFR at which exactly all the available oxygen is used to burn the fuel completely or at least to the best possible value. This ratio is called stoichiometric AFR. However, standard stoichiometric

AFR is not giving best performance when modification of modified piston geometry and compression ratio is done. The stoichiometric mixture in gasoline engine and its products are defined below:

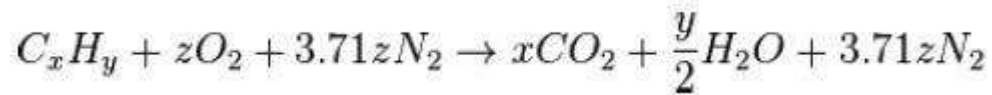

where the mixture of fuel, oxygen and nitrogen produce the products of water, carbon dioxide and nitrogen.

Relatively rich mixture of air fuel ratio of 12:1 is required by the engine while accelerating or running at high speeds. A leaner mixture of air-fuel ratio of 16:1 is sufficient while running on levelled roads. For idling, a richer mixture of about 14:1 is needed. Similarly, an extremely rich mixture having a ratio of 9:1 is required during cold starting.

Describe Carburetion process for Petrol Engine

Working of a Carburetor:

As we already knew, the Simple carburetor mainly consists of

1. Throttle Valve
2. Strainer
3. Venturi
4. Metering system
5. Idling system
6. Float Chamber
7. Mixing Chamber
8. Idle and Transfer port
9. Choke Valve

The Float and needle valve system maintains a constant level of gasoline in the float chamber.

If the amount of the fuel in the float chamber falls below the designed level, the float goes down, thereby opening the fuel supply valve and admitting fuel.

When the designed level has been reached, the float closes the fuel supply valve thus stopping additional fuel flow from the supply system.

The float chamber is vented either to the atmosphere or to the upstream side of the venturi.

During the suction stroke, the air is drawn through the venturi. Venturi is a tube of decreasing cross-section with a minimum area at the throat.

Venturi tube is also known as a choke tube and is so shaped that it offers minimum resistance to the airflow. As the air passes

through the venturi the velocity increase reaching a maximum at the venturi throat.

Correspondingly, the pressure decreases reaching a minimum.

From the float chamber, the fuel is fed to a discharge jet, the tip of which is located in the throat of the venturi.

Because of the differential pressure between the float chamber and the throat of the venturi, known as carburetor depression, fuel is discharged into the air stream.

The fuel discharged is affected by the size of the discharge jet and it is chosen to give the required Air fuel ratio.

Functions of a carburetor:

The main functions of a carburetor are

1. The main function of carburetors to mix air and gasoline and provides a high combustion mixture.
2. It controls the engine speed.
3. It also regulates the air-fuel ratio.
4. Increase or decrease the amount of mixture according to the engine speed and load changing.
5. To keep certain head of fuel in the float chamber all the time.
6. Vaporize the fuel and mix to air to a homogeneous air-fuel mixture.
7. To supply the correct amount of air-fuel mixture at the correct strength under all conditions of load and speed of the engine.

Describe Multipoint fuel injection system for Petrol Engine(MRFI)

The MPFI is a system or method of injecting fuel into internal combustion engine through multi ports situated on intake valve of each cylinder. It delivers an exact quantity of fuel in each cylinder at the right time. There are three types of MPFI systems – Batched, Simultaneous and Sequential.

In the batched MPFI system fuel is injected to the groups or batches of the cylinders without bringing their intake stroke together. In the simultaneous system, fuel is inserted to all cylinders at the same time, while the sequential system injection is timed to overlap with intake stroke of each cylinder.

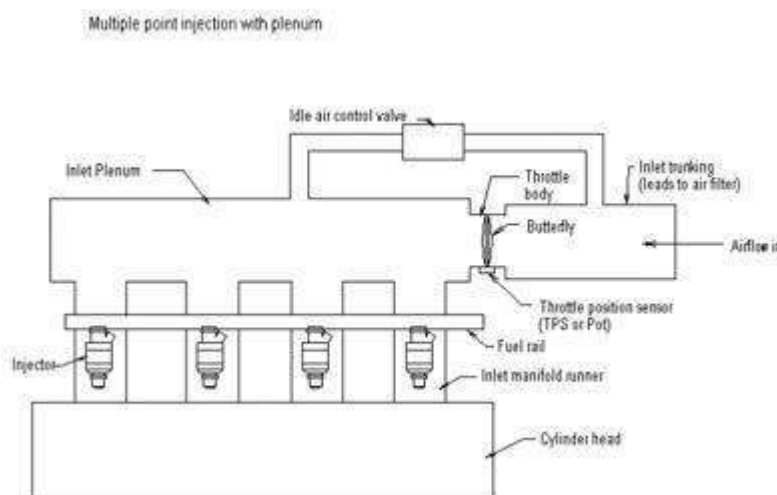

Working of MRFI

MPFI includes a fuel pressure regulator, fuel injectors, cylinders, pressure spring and a control diaphragm. It uses multiple individual injectors to insert fuel in each cylinder through intake port situated upstream of cylinder's intake valve. The fuel pressure regulator, connected to the fuel rail by means of an inlet and outlet, directs the flow of the fuel. While the control diaphragm and pressure spring controls the outlet valve opening and the amount of fuel that can return. The pressure in the

intake manifold significantly changes with the engine speed and load.

Advantages of multi point fuel injection system?

- The multi-point fuel injection technology improves fuel efficiency of the vehicles. MPFI uses individual fuel injector for each cylinder, thus there is no gas wastage over time. It reduces the fuel consumption and makes the vehicle more efficient and economical.
- The vehicles with MPFI automobile technology have lower carbon emissions than a few decades old vehicles. It reduces the emission of the hazardous chemicals or smoke, released when fuel is burned. The more precise fuel delivery cleans the exhaust and produces less toxic byproducts. Therefore, the engine and the air remain cleaner.
- MPFI system improves the engine performance. It atomizes the air in small tube instead additional air intake, and enhances the cylinder-to-cylinder fuel distribution that aid to the engine performance.
- It encourages distribution of more uniform air-fuel mixture to each cylinder that reduces the power difference developed in individual cylinder.
- The MPFI automobile technology improves the engine response during sudden acceleration and deceleration.
- The MPFI engines vibrate less and don't require to be cranked twice or thrice in cold weather.
- It improves functionality and durability of the engine components.
- The MPFI system encourages effective fuel utilization and distribution. .

Other benefits

- Smooth operations and drivability
- Reliability
- Competent to accommodate alternative fuels
- Easy engine tuning

- Diagnostic capability
- Initial and maintenance cost

Describe the working principle of fuel injection system for multi cylinder Engine

a fuel injection system for a multi-cylinder endothermic engine is provided which comprises:

a plurality of first cylinders provided along a first axis;
a plurality of second cylinders provided along a second axis which is parallel to the first axis;

a plurality of intake valves, each of which is mounted in the head of a respective cylinder;

a fuel manifold with a longitudinal axis which is parallel to the first and second axis;

a plurality of fuel supply pipes which lead to the head of a respective cylinder;

a plurality of fuel injectors, one for each cylinder, the longitudinal axis of which converges towards a median area defined between the first and second axis, and which can collect fuel from the fuel manifold and inject this fuel into a respective fuel supply pipe; and

an air intake manifold which can convey air into the fuel supply pipes;

characterized in that the injectors comprise a nozzle in which there is provided an injection hole which is defined along an axis which converges on the longitudinal axis of the injector, according to a respective and predetermined angle, and characterized in that the axis of the injection hole of the injectors which supply the first cylinders converges on the intake valve of the first cylinders, whereas the axis of the injection hole of the injectors which supply the second cylinders converges on the intake valve of the second cylinders.

For improved understanding of the present invention, a preferred embodiment is now described, purely by way of non-limiting example, with reference to the attached drawings, in which:

- Figure 1 is a schematic plan view of an injection system according to the present invention;
- Figure 2 is an enlarged cross-section along line II-II in Figure 1; and
- Figure 3 is a partial enlarged cross-section of a detail of the system in Figure 2.

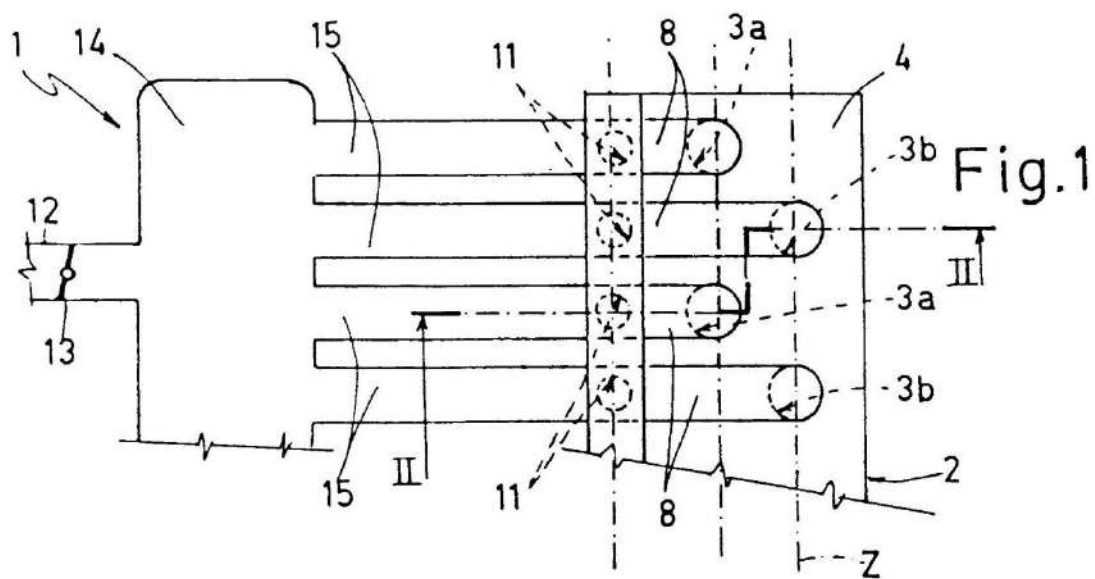

As Figure 1 illustrates, 1 indicates as a whole a fuel injection system for an endothermic engine 2 of the type which has a plurality of cylinders distributed in two rows. The engine 2 comprises a base 4 in which there are defined two parallel axes Y and Z; along the

axis Y there is provided a first plurality of cylinders 3a, and along the axis Z there is provided a second plurality of cylinders 3b. Each cylinder 3a and 3b (Figure 2) accommodates a respective piston 5, and has in its head a respective intake valve 6.

With reference to Figures 1 and 2, the system 1 comprises:

- a fuel manifold 7 with longitudinal axis X which is parallel to the axes Y and Z;

- a plurality of fuel supply pipes 8 (one for each cylinder 3a and 3b) which lead to the head of the respective cylinder 3a and 3b;

- a plurality of fuel injectors 11, one for each cylinder 3a and 3b;

- an air intake manifold 12, along which there acts a regulation valve 13 which is preferably of the throttle type;

- an expansion box 14 into which the manifold 12 leads; and

- a plurality of air supply pipes 15 which originate from the expansion box 14, and which are of the same number as the fuel supply pipes 8.

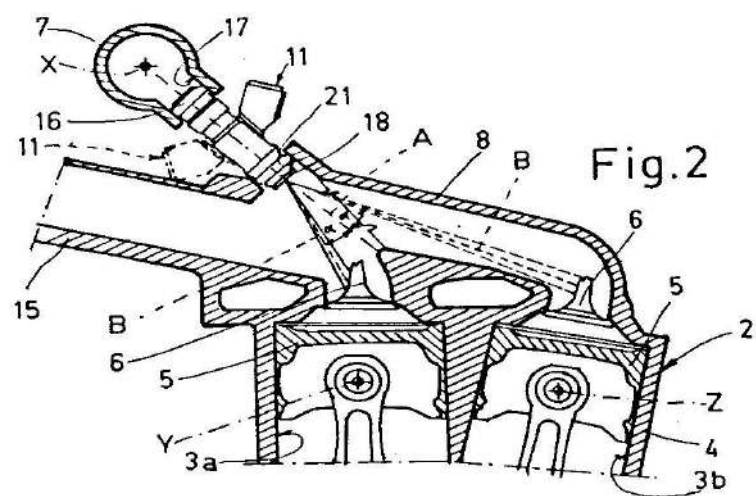

With reference to Figure 2, the injectors 11 have a head 16, in which there is recessed the fuel inlet mouth, which is accommodated in a respective seat 17 recessed in the fuel manifold 7, and a nozzle 18 (Figure 3) which is accommodated in a seat 21 recessed along the respective fuel supply pipe 8. The fuel manifold 7 is mounted to the side of the base 4, and in particular in the vicinity of the axis Y, such that the pipes 8 which supply the cylinders 3a have a length which is shorter than that of the pipes 8 which supply the cylinders 3b. The injectors 11 have a respective longitudinal axis A which converges towards an area of the base 4 in a median position between the axes Y and Z. The axes A of all the injectors 11 are defined on a single plane, i.e. all the injectors 11 have the same angle relative to the longitudinal axis X of the fuel manifold 7. The air supply pipes 15 lead to a respective fuel supply pipe 8, inside which the air and fuel are mixed in order to obtain the air-fuel mixture which the cylinder 3a, 3b will take in by means of the valve 6 during the intake stage.

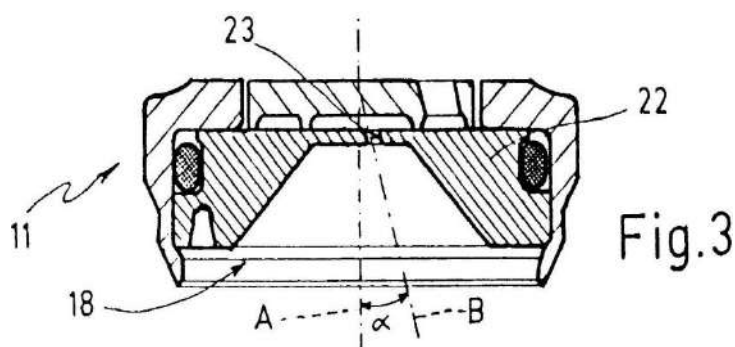

With reference to Figure 3, the nozzle 18 of the injector 11 has a plate 22 in which there is provided an injection hole 23 defined along an axis B which converges on the axis A according to an angle α ; the

fuel jet is thus not in line with the axis A but is at an angle α relative to the latter.

With reference to Figure 2, the injectors 11 which supply the cylinders 3a are oriented differently, and in particular are rotated around the axis A by 180° relative to the injectors 11 which supply the cylinders 3b. The orientation of the injectors 11 which supply the cylinders 3a, and the angle α of the fuel jet relative to the axis A, cause the fuel jet to strike fully the valve 6 of the cylinders 3a. Whereas the orientation of the injectors 11 which supply the cylinders 3b and the angle α of the fuel jet relative to the axis A, cause the fuel jet to strike fully the valve 6 of the cylinders 3b, this latter solution being illustrated in broken lines in Figure 3.

According to the above description, the advantages obtained by implementing the present invention are clear.

In particular, an injection system is provided according to which all the cylinders use the same injectors, in which the injection hole is at an angle relative to the axis of the injector. If the injector is now positioned according to a predetermined orientation of the injection hole axis, the fuel jet can be directed against the intake valve of the closer cylinder or of the further cylinder. This aimed direction of the fuel jet does not give rise to the depositing of particles on the walls of the fuel supply pipe, since these walls are not along the axis of the jet. Consequently, all the quantity of fuel injected is then taken in by the cylinder, and in addition there is

no distortion of the stoichiometry prescribed for the air-fuel mixture.

Finally, it is clear that modifications and variants may be applied to the system 1 described and illustrated here, without departing from the protective context of the present invention.

In particular, the system 1 can contain any number of cylinders distributed in two rows, and can include injectors of a type other than that described. The cylinders of one row can have their longitudinal axis parallel or converging with the longitudinal axis of the cylinders of the other row. In addition, the injectors which supply the cylinders 3a could have their injection holes defined along angled axes, with an angle which differs from that of the injection holes of the injectors which supply the cylinders 3b.

According to a different embodiment, all the injectors could have the same orientation, and include a plate 22 which can be pivoted around the axis A in order to determine the injection hole 23 defined on an axis which converges on the respective intake valve 6.

Claims (4)

Hide Dependent

1.

Fuel injection system for a multi-cylinder endothermic engine (2) comprising;

- a plurality of first cylinders (3a) provided along a first axis (Y);
- a plurality of second cylinders (3b) provided along a second axis (Z) which is parallel to the first axis (Y);
- a plurality of intake valves (6) each of which is mounted in the head of a respective cylinder (3a, 3b);
- a fuel manifold (7) with a longitudinal axis (X) which is parallel to the first and second axis (Y and Z);
- a plurality of fuel supply pipes (8) which lead to the head of a respective cylinder (3a, 3b);
- a plurality of fuel injectors (11), one for each cylinder (3a, 3b), the longitudinal axis (A) of which converges towards a median area defined between the first and second axis (Y and Z), and which can collect fuel from the fuel manifold (7) and inject this fuel into a respective fuel supply pipe (8); and
- an air intake manifold (12) which can convey air into the fuel supply pipes (8);

characterized in that the injectors (11) comprise a nozzle (18) in which there is provided an injection hole (23) which is defined along an axis (B) which converges on the longitudinal axis (A) of the injector (11) according to a respective and predetermined angle (α), and characterized in that the axis (B) of the injection hole (23) of the injectors (11) which supply the first cylinders (3a) converges on the intake valve (6) of the first cylinders (3a), whereas the axis (B) of the injection hole (23) of the injectors (11) which supply the second cylinders (3b) converges on the intake valve (6) of the second cylinders (3b).

2. System according to Claim 1, characterized in that all the injectors (11) have the same angle between their

own longitudinal axis (A) and the axis (B) of their own injection hole (23).

3. System according to Claim 2, characterized in that the injectors (11) which supply the first cylinders (3a) are oriented differently, and in particular are rotated around their own longitudinal axis (A) by 180° relative to the injectors (11) which supply the second cylinders (3b).
4. System according to Claim 2, characterized in that all the injectors (11) have the same orientation, and in that the nozzles (18) of the injectors (11) which supply the first cylinders (3a) are oriented differently, and in particular are rotated around the longitudinal axis (A) by 180° relative to the nozzles (18) of the injectors (11) which supply the second cylinders (3b).

Filter for Diesel engine

The fuel filter of diesel engine can filter out the harmful impurities and moisture in the fuel system, protect the normal work of the engine, reduce wear and tear, avoid clogging and improve diesel engine life. Here, we are willing to share the basic working principle of diesel engine fuel filter.

Basic Working Principle of Diesel Fuel Filter

The purpose of any diesel fuel filter is to remove foreign particles as well as water. The use of a suitable filtration system on diesel engines is a must to avoid damage to closely fitted

injection pump and injector components. Filter's ability varies between the type and manufacturer. On diesel engines primary and secondary filters are used. The primary filter is capable of removing dirt particles down to 30 microns and the secondary filter between 10 to 12 microns. Secondary filters are available between 3 and 5 microns, which are used in severe service operations. The primary filter is usually located between the tank and the supply pump, the FWS is one type of the primary filters. The secondary filter between the supply pump and the injection pump.

Diesel fuel filter is referred to as full-flow filter, because all the fuel must pass through it before reaching the injection pump. Some filters use internal replaceable element inside a bowl or shell. These are commonly referred to as a shell and element design. Most fuel filters used today are of the spin-on type, which allow for faster change out since the complete filter is a throwaway.

Besides, if the filter is installed on the pressure side of the boost pump it must have sufficient strength to handle pump pressure without bursting or leaking. The filter must be located well away from sources of heat, preferably outside of the engine compartment.

Components

The fuel filter of diesel engine is mainly composed of three parts: filter element, the shell and filter base (As shown in Figure 1). All models are universal except for the overflow valve 8 that has two structures. Choosing C0810A or C0810B filter should be on the basis of different models. For the 12 cylinder V type diesel genset, it should be installed in parallel with each one of C0810A and C0810B.

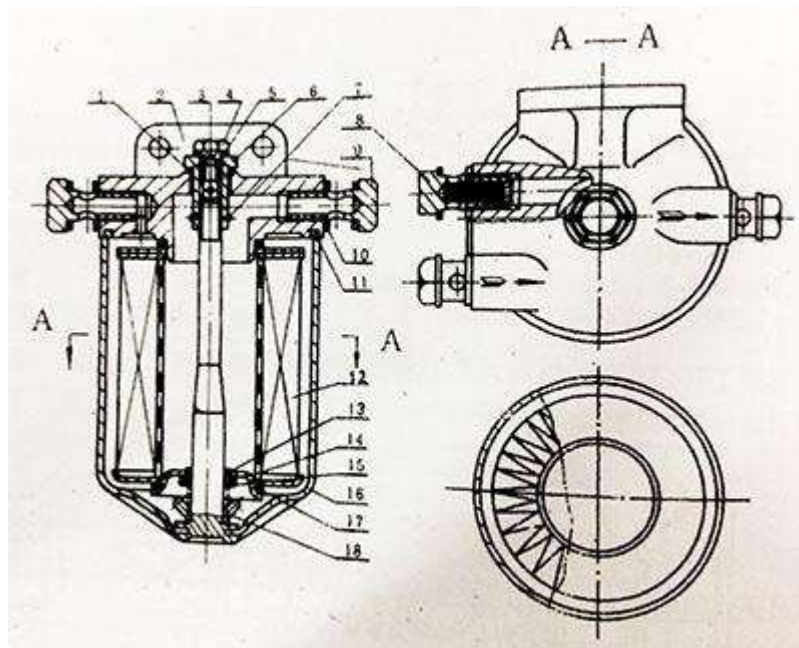

Figure 1: Fuel filter assembly section

1. Gasket
2. Base of filter
3. Pull rod
4. Bleed screw
5. Gasket
6. Pull-rod nut
7. Jump ring
8. Overflow valve
9. Oil pipe connection
10. Seal ring
11. Sealing washer
12. Filter element
13. Seal ring
14. Tray
15. Spring seat
16. Shell
17. Seal ring
18. Spring

The fuel is sent to the fuel filter mainly by the fuel pump. The impurities in the fuel will be cleared through the paper filter element. And then the fuel can enter the inner cavity of the filter cylinder. Through the collection chamber of the filter sea, it leads to the fuel injection pump. The filter holder is equipped with fuel return fitting and the overflow valve is also installed inside. When the fuel pressure in the fuel filter is more than 78kPa (0.8kgf/C m^2), the excess fuel will return back to the fuel tank from the fuel return fitting. When connecting the low pressure fuel line, you should connect it according to the arrow pointing direction on the socket to avoid connection error. The filter seat and the shell are connected by pull rod, and it is sealed by rubber ring. Due to there is a bleeder plug on the top of filter seat, users can release the screw to clear the air of the fuel filter in use.

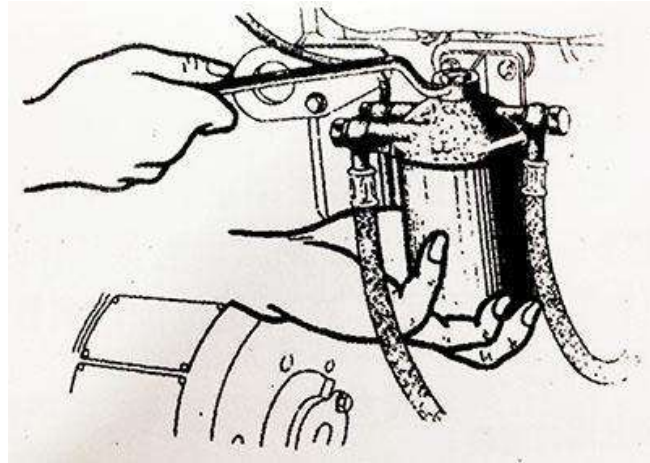

Figure 2: Fuel filter overhauling

The fuel filter of the diesel engine is fixed on the engine body and bracket with two M8-6H screws. If users find that the fuel supply is not smooth, it is possible that the filter element is plugged. At the moment, you should dump the fuel oil. You can directly loosen the pull rod nut of diesel generator set, remove the shell, and take out the filter cartridge (As shown in Figure 2). After the filter element is dipped into gasoline or diesel oil, you can gently wash the dirt off with brush (As shown in Figure 3). If the filter cartridge is broken or hard to clean, it must be renewed. Then install it as shown in Figure 1 and inject the clean fuel.

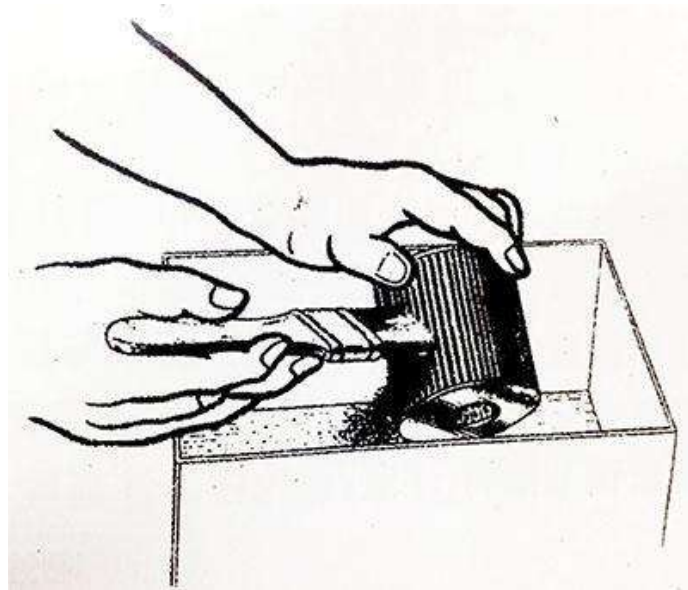

Figure 3: Cleaning fuel filter element

Describe the working principle of Fuel feed pump and Fuel Injector for Diesel engine

Fuel feed pump diesel engine construction and working

Fuel feed pump diesel engine is a mechanical device which works for supplying the fuel. The fuel feed pump diesel engine brings fuel from fuel tank and sends to the filters, FIP and injectors. Fuel feed pump has driven by engine cam shaft.

Construction of fuel feed pump diesel engine;

The *fuel feed pump diesel engine* have a fuel inlet which is connected with fuel tank by the fuel feed pump pipe line. It also have a fuel outlet which is connected with filter and FIP by the low pressure pipeline

The fuel feed pump diesel engine have two check valve namely inlet check valve and outlet check valve, both are fitted inside the pump body at inlet and outlet of the fuel

For airlock removing operation the fuel feed pump diesel engine have a manual operating lever. For normal cleaning of the fuel it has a gauge filter inside the body.

There is a plunger fitted inside the fuel feed pump diesel engine body and to keep in initial position of the plunger there is a returning spring provided.

There is a continuity channel casted inside the body which makes continuity of fuel supply for the system.

WORKING OF FUEL FEED PUMP DIESEL ENGINE

There are two different workings:

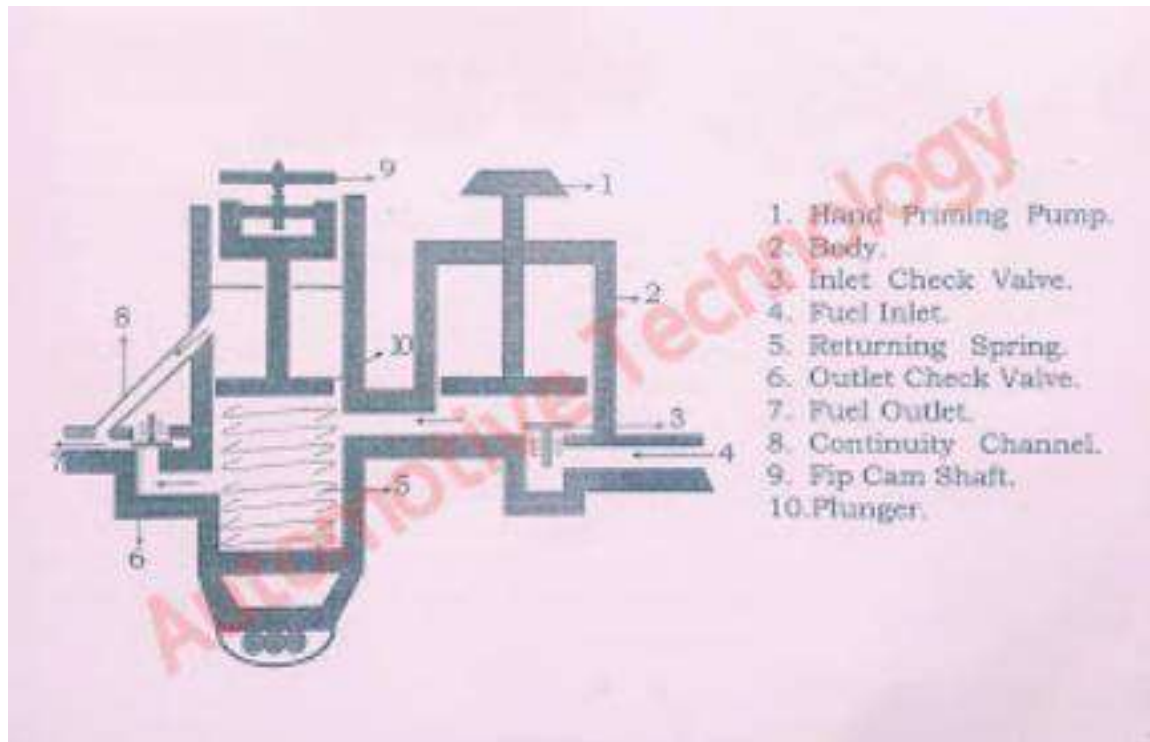

1. Manual operation while removing airlock:

When vehicle is getting off because of the airlock in the fuel supply system.

Now the user has to open the manual priming lever and start priming by pulling and pushing this lever

Continuous priming of the lever there is a suction being created and takes fuel from fuel tank and supply to the system.

2. Fuel supply while the engine is starting

During starting the engine the cam shaft of the engine gives drive to the fuel feed pump diesel engine. The plunger starts moving front and back. When the plunger comes back then suction takes place inside the body. Because of this suction fuel flows from fuel tank and filled into the pump body by opening the inlet check valve.

When the plunger goes front then it makes pressure on the fuel and fuel flows to the system by opening the outlet check valve. During fuel outlet some fuel goes behind the plunger through the continuity channel, while plunger goes back again the fuel comes from fuel tank into the pump body but the fluid behind the plunger flows to the system and then there is continuity of fuel supply.

6.0 ELECTRIC AND HYBRID VEHICLES:

Introduction, Social and Environmental importance of Hybrid and Electric Vehicles

Since the dawn of the modern era, consumption and distribution of energy has quickly become mankind's highest priority. However, the continued apathetic attitude that was initially taken toward energy and its side effects can no longer be used. A new more environmentally friendly source of energy has to be utilized in order to fulfill our own needs otherwise we selfdestruction while relying on non-renewable oil based methods. In the last few decades two new technologies have emerged; the development and implementation of Hybrid Electric Vehicles (HEVs) and more recently the Plug-in Hybrid Electric Vehicles (PHEVs). These emerging technologies may make it possible for the United States to adapt these technologies on a larger scale to reduce harmful emissions and cut our dependence on foreign oil dramatically. However, the future of the technologies will heavily depend on the everyday American consumer's willingness to forgo the 'tried and true' combustion engine for the infantile technologies of the HEV and PHEV. With the introduction and continued popularity of HEVs and as well as the recent hype over the PHEVs, the future of transportation in the United States is on the brink of change.

First, verify if independence of foreign oil is truly a possibility and how to accomplish this feat. Second, identify the major motivators for the American consumers who purchase these vehicles and how that can be used to increase the sales of HEVs and PHEVs respectively. The third and last objective is to determine the future impact of the all electric vehicle (EV). Earlier civilizations relied on a number of power sources such as

water to turn wheels, to run mills, fire to heat water and create steam, or windmills to turn grinding stones. Since roughly Environmental and Social Issues Concerned with Hybrid Cars 5 the 17th century various forms of oil have been used, such as kerosene, as fuel for lanterns. Even into the 18th , 19th , and early 20th centuries whales were hunted for their blubber which could be converted into oil among other things. In the more recent years with the invention of the combustion engine, which has not only increased the sheer amount of oil consumed annually but also drastically augmented our dependence upon it in our daily lives.

Our oil 'addiction' has lead us to the realization that our usage has its limits, not only does the environment suffer adverse effects because of its use but our society is so dependent upon that if it were suddenly removed, most of modern society would cease to function properly if it all. Without a reasonable alternative this fate is all too possible and this has caused huge concerns over how, on a large scale, we can change our consumption habits and create a cleaner energy for our use.

Hybrid cars have come a long way in the past 20 years, but most people are unaware they have been around since the mid 1800s. The early electric vehicles at the turn of the 20th century were expensive, problematic and not very powerful. Given certain weather conditions or too steep a hill the electric vehicle of yesteryear was simply unable to perform up to our expectations.

With the introduction of the Ford Model T, a revolution in vehicles was made. The Model T was cheaper and more powerful and was made relatively simplistic, it also ran on a then abundant source of gasoline, and the United States could meet its own internal demand enough so that it actually exported its excess to European countries such as France and Britain. Ultimately, the Model T made the early EVs defunct and as such

fell off the radar until events like the 1973 oil crisis and 1979 energy crisis where the electric technologies were eventually reconsidered.

The first electric car is claimed to have been built between 1832 and 1893 by Robert Anderson of Scotland. From then until the late 1800s, when they became efficient enough to use as taxi cabs in England, the cars were heavy, slow and impractical. Modern batteries development in the early 1900s pushed the development of more efficient, reliable, and practical electric cars in that period.

The Hybrid came about in 1900 in Belgium, when a small gasoline engine was paired with an electric motor. During normal operation the electric motor charged onboard batteries, but during acceleration and uphill stints the electric motor provided a boost to the 3.5 horsepower motor. In 1905 H Piper patented the first hybrid in America. In 1910 a hybrid truck was manufactured in Pennsylvania, which used a 4 cylinder to power a generator and an electric motor. 1916 saw the production of hybrid cars claiming 35 mph and 48 mpg, however this also saw the end of the electric car era due to the advances in combustion engine technology.

Until the mid to late 1960s, there is little commercial advance in hybrid or electric cars. As early as the mid 1960s congress recognized the importance of reducing emissions to improve air quality, and that the use of electric cars was a possible way to achieve this. In the late 60s and early 70s the oil embargo sparked a renewed interest in hybrid and electric vehicles. A few hybrids were released by major manufacturers, but most were underpowered and small. More importantly, three scientists patented the first modern hybrid system in 1971, much of which closely resemble the hybrids of today.

The next big push from congress comes with the 1976 Electric and Hybrid Vehicle Research, Development, and Demonstration Act which encouraged the commercial improvement of electric motors and other hybrid components. The research led toward new developments and new vehicles released in the United States, including all electrics from GM and Honda, even including an electric truck, the Chevrolet S-10. These vehicles reached a niche group, but still did not receive the sales numbers Environmental and Social Issues Concerned with Hybrid Cars 7 to be feasible. This all changed with the release of the Toyota Prius in Japan in 1997.

With 18000 sold in the first year it becomes the first economically feasible hybrid produced. With its import to the United States in 2000 and the release of Honda's Insight to the US in 1999 the hybrid age had finally arrived. However, PHEVs and HEVs are not without limitations, which are mainly caused by the current state of battery technology. With future research and development into creating improvements on battery technology many of the limitations will be greatly reduced if not expunged completely.

We have come a long way since the nickel and lead batteries of the 1960s, more recently the Nickel Metal Hydride and Lithium Ion battery technologies have been developed and successfully implemented. Today's HEVs are a far cry from the small four horse power models of the 1800s, modern HEVs include the same power, acceleration, comfort, and price of their counterpart conventional cars (CVs), but can reach upwards of 50 miles per gallon depending on the model

Impact of Hybrid Cars on the Environment

One of the major technologies found to have a significant contribution towards carbon emission reduction is the Hybrid Electric Vehicles or HEVs. This new type of vehicle is being praised for fuel efficiency and ultimately being environmental friendly.

On the other hand, there are contradicting arguments regarding the impact of HEVs on the environment, which needs to be examined further. The environmental implications of HEVs can be better explored when observed in a smaller region where the data is more specific. Fuel prices in Oman are at a record high despite the fact that the country is a major global producer of petroleum products. As a result, a significant number of car owners in the country are shifting to HEVs.

However, the shift towards HEVs is more on the economic than environmental position. In this regard, the discussion will explore how the shift towards HEVs impacts the environment specifically in Oman. Hybrid Cars vs. Traditional Cars There are two major questions that car consumers in Oman asks today when purchasing new vehicle, and that is whether the car is fuel efficient and environment friendly. Only HEVs have the highest potential for meeting the aforementioned two conditions. However, to compare conventional versus HEVs it is important to note pros and cons of each type. For HEVs, the advantage is higher mileage, high resale value, uses cleaner energy, but the tradeoff would be a higher price tag, higher maintenance cost, and no sport-tuned suspensions (Lexus, N.D.).

On the other hand, conventional fuel cars command a lower price tag, better engine power, and low maintenance cost, but the drawbacks would be harmful emissions and low mileage. A report published by Argonne in 2009 suggests that HEVs offer

90% reduction on petroleum energy use and 40-80% reduction on greenhouse gas emission (Elgowainy et al., 2009). Carbon Footprint and Environmental Impact in Oman In the case of Oman, the current environmental statistics suggests that carbon emission in the country is on a steady increase since the early discovery and production of oil and gas.

From 1972 to 2011 there has been steep climb on the total CO₂ emissions in Oman from 2,000 Gg to 40,000 Gg (Abdul-Wahab et al., 2015). Similarly, the study conducted by Yousif et al. (2017) shows a forecasted further increase in CO₂ and greenhouse gas emissions of nearly 60 million tons in the country in the next decade. The major contributors of these emissions are continuous fuel combustion at 57.9, manufacturing at 24.2 and transportation at 12.3 .

The CO₂ emitted by conventional cars in the country are added on both transportation and fuel combustion segments, which encompasses a much higher statistic when combined. In this regard, the Sultanate of Oman is seeing the potential of HEVs to counter the continuously increasing CO₂ and GHG emissions in the country .

In 2015, major car brands introduced HEVs in Oman such as Toyota Prius, which is spearheading the shift to HEVs across the Middle East (Times of Oman, 2016). Expectations of the car model 3 / 14 Journal of Student Research Fourth Middle East College Student Research Conference, Muscat, Sultanate of Oman (2019) ISSN: 2167-1907 (www.jofsr.org) suggest that it is likely to reduce approximately 67 million tons of CO₂ emission over the span of 20 years (Times of Oman, 2016). To date it is not certain how many of the HEVs were deployed in Oman, hence, the exact measure of its impact towards the country's CO₂ emission reduction is still undetermined (CMS, 2018). There are several challenges observed in terms of further

deployment of HEVs in Oman and one of them is the establishment of regulators that will oversee the operations encompassed by the introduction of HEVs in the country. One of the primary considerations is who would be responsible for the implementation and regulation of facilities such as charging stations, tariff fixing, and government registration and requirements (CMS, 2018).

RESULTS

The topic of hybrid cars was keenly inspected. The major parts of it were broken down and critically analyzed. The study produced results that could positively affect everyone involved. With respect to different aspects, the results reviewed are as produced below:

Environmental Impact The first and one of the most important result of implementing hybrid cars usage, is the environmental factor. According to the survey conducted among 36 people, 88% of the respondents agreed that air pollution has increased due to the automobiles on road. Cars driven in the city, when they run on low speeds, or are stuck in heavy traffic, the regular gasoline cars keep the engine running which at the same time exhales fumes causing increasing air pollution on extreme levels.

The same situation when applied to hybrid cars, they smartly switch to the electric motor, causing zero fuel consumption and zero air pollution. This not only contributes to saving money but also to a greener and healthier environment.. **Money Saver** The survey shows that on an average around 66% of people agreed to spending between 50 – 60 OMR / month. **Journal of Student Research Fourth Middle East College Student Research Conference, Muscat, Sultanate of Oman (2019) ISSN: 2167-1907** OMR per month just on petrol/diesel. Going by the figure 60, that is 720 OMR per year. And people that fall into the more

than 70 category; that would sum up to a whopping 960 OMR per year.

For most of the people, 960 to 1000 OMR per year is a huge amount to be wasted just for refilling cars. With hybrid vehicles in place, this number is sure to come down by a few hundreds, saving money in the long term. Safety Referring to the report issued by Insurance Institute for Highway Safety, it claimed that in crash tests, hybrid cars performed better than the regular gas cars. The data showed that the people within a hybrid vehicle would be 25% less injured than a same standard gasoline vehicle, as well as the driver's death rate showed a reduction when it came to hybrid models. The reason the hybrid models executed well in the crash tests was due to the heavy weight they carry.

According to the reports, these models are 10% more heavier than the regular gasoline cars, and hence when they crash, the heavier vehicle tends to have a greater impact on the light weighted gasoline counterparts and pushes it backwards. (Edgerton, 2011) For example, the hybrid variant of Accord is 217 kg's more than the standard Accord. A lot of news is surrounded around the topic of how Lithium Ion battery used in these vehicles could prove dangerous by getting overheated and may also catch fire. Companies manufacturing and producing hybrid cars have stated that it takes a long process to modify and tame the li-ion batteries to make it safer and runnable for years (Tajitsu, 2016).

Along with the newly modified and now much safer lithium ion batteries, Tesla Motors mentioned that they developed a cooling system and have also created sensors and fuses up to three layers of protection to safeguard the batteries from overcharging. The role of the fuses and the sensors is to immediately disengage the battery in use, when there is a rise in the temperature, a roll-over or an unexpected impact. From a

safety point of view, the makers decided to use a number of smaller batteries in comparison to a few large ones, since the energy stored will also be in small amounts and enclosed within its own steel cases, it will also prove safer.(Bullis, 2006)

DISCUSSION The main objective of this research is to analyze Hybrid-Electric Vehicles (HEV) and their components and justify how these vehicles are less harmful than gasoline cars to the environment. This is done by analyzing and conspicuously explaining how an HEV works, its characteristics and the components that differentiate it between traditional gasoline.

The result after testing the vehicles and researching and understanding its components is that HEV does is indeed less harmful to the environment due to it consuming less gasoline and because the components; mainly the battery and motor, are naturally built to be less impactful to the environment. This research also aims to encourage consumers into buying HEV. If the number of total hybrid vehicles increase and the total number of gasoline vehicle decrease, the total amount of pollution caused by vehicles would drastically decrease due to the total consumption of gasoline decreasing as large amounts of gasoline won't be needed to fulfill the needs of hybrid vehicles.

This ultimately reduces environmental pollution caused by vehicles. Along with the reduction of pollution, the amount of money saved of fuel refilling's could be turn out to be helpful for most of the individuals, who are struggling with balancing their budget.

CONCLUSION

All the above topics, which have been analytically studied, it concludes that the hybrid vehicles prove to be more eco-friendly and safer for the environment than the IC engine

vehicles. With increasing production of hybrid variants, batteries are being planned and designed in way that extends its life as well as provides the ability of recycling.

This all in all, turns to be safer, healthier 11 / 14 Journal of Student Research Fourth Middle East College Student Research Conference, Muscat, Sultanate of Oman (2019) ISSN: 2167-1907 (www.jofsr.org) and also a money saver package, saving you a fine amount spent on fuel. Investigation into other vitality sources, for example, power devices and sustainable powers make the future look more splendid for hybrid vehicles.

RECCOMENDATIONS

Many people have the conception of hybrid vehicles being a lot more expensive than the regular gasoline vehicles.

The truth in fact, is that the hybrid types cost only a very few more thousands than the gasoline types of the same model. For example; the Hyundai Sonata Hybrid costs \$26,000, whereas the gasoline counterpart costs \$22,000. In the long run, these few extra thousands will cover up the huge amount spent on fuel yearly. It was also witnessed that the EU is providing incentives for people who use fully electric cars, such as reduced taxes and other similar traits. A similar trait can be introduced and implemented in GCC counties to encourage the purchase of hybrid vehicles, like for example reduced gas rates per liters for certified hybrid cars.

Due to the nature of electric cars, it doesn't seem like a viable solution; at least in GCC to implement them since they are the most environmentally friendly vehicles due to the exclusion of an IC engine. The reasons behind this are: electric cars don't cover enough millage without needing to be recharged. Based on experiments conducted, the most distance that an electric

car was able to attain by driving in specific conditions was approximately 300kilometers without needing to charge the car. Another reason is that there are not enough charging stations. Until that reality comes into fruition, hybrid vehicles are deemed to be the most viable solution to reduce pollution; at least in the GCC.

Description of Electric Vehicles, operational advantages, present performance and applications of Electric Vehicles

The **electric car** (EV) is a relatively new concept in the world of the automotive industry. Although some companies have based their entire model of cars around being proactive and using electricity, some also offer **hybrid vehicles** that work off both electricity and gas.

An electric car such as Nissan Leaf, Ford Focus Electric or Tesla Model S, Chevrolet Volt is a great way for you to not only save money but also help contribute towards a healthy and stable environment.

Cars produce a lot of **carbon emissions** that are ejected into our natural atmosphere, leaving us vulnerable to things like **pollution** and **greenhouse gases**. In order to positively help the environment we live in, an electric car is a great step forward.

By buying an electric car, you can also receive government subsidies for **being environmentally conscious**. Although you may end up paying more for your vehicle, the positives greatly overshadow the negatives. However, there are still two sides to consider when you're thinking about investing in an electric vehicle.

EV's get their power from rechargeable batteries installed inside the car. These batteries are not only used to power the car but also used for the functioning of lights and wipers.

Electric cars have more batteries than a regular gasoline car. It's the same kind of batteries that are commonly used when starting up a

gasoline engine. The only difference comes in the fact that in electric vehicles, they have more of them, which are used to power the engine.

Advantages of an Electric Car

An electric car can be a great way for you, as a consumer, to save a lot of money on gas. However, there are so many different reasons why you should invest in an electric car in the modern-day of technology.

1. No Gas Required

Electric cars are entirely charged by the electricity you provide, meaning you don't need to buy any gas ever again. Driving fuel-based cars can burn a hole in your pocket as prices of fuel have gone all-time high.

The average American pays about 15 cents a mile to drive a gas-powered vehicle, whereas many electric cars run on five cents a mile. Electricity is largely less expensive than gasoline.

If most people charge their cars in the garage installing a few solar panels, that price can get cut even further, offering savings on powering your entire home. With electric cars, this cost of \$2000 – \$4000 on gas each year can be avoided.

2. More Convenient

The electric vehicle is easy to recharge, and the best part is you will no longer need to run to the fuel station to recharge your car before hitting the road! Even a normal household socket could be used for charging an electric car.

3. Savings

These cars can be fuelled for very low prices, and many new cars will offer great incentives for you to get money back from the government for [going green](#). Electric cars can also be a great way to save money in your own life.

4. No Emissions

The biggest advantage of an electric vehicle is its green credential. Electric cars are 100 percent eco-friendly as they run on electrically powered engines.

It does not emit [toxic gases](#) or smoke in the environment as it runs on [a clean energy source](#). They are even better than [hybrid cars](#) as hybrids running on gas produce emissions. You'll be contributing to a healthy and green climate.

5. Popularity

EV's are growing in popularity. It is nearly three times as efficient as cars with an internal combustion engine, according to Wikipedia. With popularity comes all new types of cars being put on the market that are unique, providing you with a wealth of choices moving forward.

6. Safe to Drive

Electric cars undergo the same fitness and testing procedures test as other fuel-powered cars. An electric car is safer to use, given their lower center of gravity, which makes them much more stable on the road in case of a collision.

In case an accident occurs, one can expect airbags to open up and electricity supply to cut from the battery. This can prevent you and other passengers in the car from serious injuries. They are even less likely to explode in the absence of any combustible fuel or gas.

7. Cost-Effective

Earlier, owning an electric car would cost a bomb. But with more technological advancements, both cost and maintenance have gone down.

The mass production of batteries and available tax incentives further brought down the cost, thus, making it much more cost-effective. Consult a tax specialist to learn more about any tax credits that might be available to you on the state or federal level.

8. Low Maintenance

Electric cars run on electrically powered engines, and hence there is no need to lubricate the engines, anything related to the combustion engine or a ton of maintenance tasks that are usually associated with a gas engine.

Other expensive engine work is a thing of the past. Therefore, the maintenance cost of these cars has come down. You don't need to send it to the service station often as you do for a standard gasoline-powered car.

9. Reduced Noise Pollution

Electric cars put a curb on [noise pollution](#) as they are much quieter. Electric motors are capable of providing smooth drive with higher acceleration over longer distances. Many owners of electric cars have reported positive savings of up to tens of thousands of dollars a year.

10. Battery Life & Cost

Batteries are an integral part of an electric vehicle. Most electric vehicle batteries are lithium ones, and their costs are improving every year.

The full capacity of a lithium-ion battery cell should be good for 300 to 500 cycles. A good battery could last you up to ten years. With the improving technologies, the cost of these batteries is expected to come down even more.

11. Easy Driving

In the world of automobiles, electric cars have the simplest driving method. Commercial electric cars come with a transmission comprising of only one really long gear and also don't suffer from the stalling problem as petrol cars do.

This effectively eliminates the need to add a clutch mechanism to prevent that from happening. Therefore, you can operate an electric car with just the accelerator pedal, brake pedal and steering wheel.

Another really useful feature is regenerative braking. In normal cars, the braking process is a total wastage of kinetic energy that gets released as

frictional heat. However, in an electric vehicle, the same energy is used to charge the batteries.

Considering the demand for oil will only be going up as the supplies run out, an electric car will most likely be the normal [mode of transportation](#) in the coming future.

Companies like Nissan and Tesla offer great electric models with an outstanding amount of benefits for people who decide to invest. You'll be saving not only yourself but also your family a huge amount of money.

The [environmental impact](#) of an electric car is zero, as well, meaning you're reducing your [carbon footprint](#) and positively affecting the economy.

APPLICATIONS OF ELECTRIC VEHICLE

.Consumer electronics

.public transportation

.aviation

.electricity grid

.renewable energy storage

.military

.spaceflight

.wearable technology

6.3 Battery for Electric Vehicles, Battery types and fuel cells

An electric vehicle battery (EVB, also known as a traction battery) is a [rechargeable battery](#) used to power the [electric motors](#) of a [battery electric vehicle](#) (BEV) or [hybrid electric vehicle](#) (HEV). Typically [lithium-ion batteries](#), they are specifically designed for high [electric charge](#) (or energy) capacity.

Electric vehicle batteries differ from [starting, lighting, and ignition](#) (SLI) batteries as they are designed to give power over sustained periods of time and are [deep-cycle batteries](#). Batteries for electric vehicles are characterized by their relatively high [power-to-weight ratio](#), [specific energy](#) and [energy density](#); smaller, lighter batteries are desirable because they reduce the weight of the vehicle and therefore improve its performance. Compared to liquid fuels, most current battery technologies have much lower [specific energy](#), and this often impacts the maximum all-electric range of the vehicles.

The most common battery type in modern [electric vehicles](#) are lithium-ion and [lithium polymer](#), because of their high energy density compared to their weight. Other types of rechargeable batteries used in electric vehicles include [lead–acid](#) ("flooded", deep-cycle, and [valve regulated lead acid](#)), [nickel-cadmium](#), [nickel–metal hydride](#), and, less commonly, [zinc–air](#), and [sodium nickel chloride](#) ("zebra") batteries.[1] The amount of electricity (i.e. electric charge) stored in batteries is measured in [ampere hours](#) or in [coulombs](#), with the total energy often measured in [kilowatt-hours](#).

Since the late 1990s, advances in lithium-ion battery technology have been driven by demands from portable electronics, laptop computers, mobile phones, and power tools. The BEV and HEV marketplace has reaped the benefits of these advances both in performance and energy density. Unlike earlier battery chemistries, notably [nickel-cadmium](#),

lithium-ion batteries can be discharged and recharged daily and at any state of charge.

The battery pack makes up a significant cost of a BEV or a HEV. As of December 2019, the cost of electric vehicle batteries has fallen 87% since 2010 on a per kilowatt-hour basis.^[2] As of 2018, vehicles with over 250 mi (400 km) of all-electric range, such as the [Tesla Model S](#), have been commercialized and are now available in numerous vehicle segments.

In terms of operating costs, the price of electricity to run a BEV is a small fraction of the cost of fuel for equivalent internal combustion engines, reflecting higher [energy efficiency](#).

Types of Electric Car Batteries

Electric car batteries are different from SLI batteries (starting, lighting and ignition). SLI batteries are batteries that are usually installed in gasoline or diesel cars. This type of electric cars battery is designed as an energy storage system, capable of delivering power for long and sustainable periods.

There are 5 types of electric vehicle batteries to be discussed in this article:

- Lithium-Ion (Li-On)
- Nickel-Metal Hybrid (NiMH)
- Lead Acid (SLA)
- Ultracapacitor
- ZEBRA (Zero Emissions Batteries Research Activity)

The comparison of the first four types of electric car batteries can be seen as

follows:

Understanding Electric Car Batteries				
	Lithium Ion	Nickel-Metal	Lead-Acid	Ultracapacitors
Easy Access / Inexpensive	✓	✗	✓	✗
Energy Efficient	✓	✓	✓	✓
Temp. Performance	✓	✗	✗	✓
Weight	✓	✓	✓	✓
Life Cycle	✓	✗	✓	✗

© EnergySage

Lithium-Ion Battery (Li-On)



This type of electric vehicle battery is most widely applied is the Li-On battery. This battery may already be familiar to us because it is also used in many portable electronic equipment such as cellphones and laptops. The main difference is a matter of scale. Its physical capacity and size on electric cars is much greater – this is often referred to as a traction battery pack.

Li-on batteries have a very high power to weight ratio. This type of electric car battery is high energy efficiency. Performance at high temperatures is also good. The battery has a greater energy ratio per weight – a parameter that is very important for electric car batteries. The smaller the battery weight (same kWh capacity) means the car can travel further with a single charge.

This battery also has a low “self-discharge” level, so the battery is better than any other battery in maintaining its ability to hold its full charge.

In addition, most parts of Li-on batteries can be recycled, making it the right choice for those interested in environmentally conscious electric cars. BEV cars and PHEVs use the most lithium batteries.

Li-on battery Types

- Lithium Iron Phosphate(LiFePO4) — LFP
- Lithium Nickel Cobalt Aluminum Oxide (LiNiCoAlO2) — NCA
- Lithium Nickel Manganese Cobalt Oxide (LiNiMnCoO2) — NMC
- Lithium Titanate (Li2TiO3) — LTO
- Lithium Manganese Oxide (LiMn2O4) — LMO
- Lithium Cobalt Oxide(LiCoO2) — LCO

Li-ion battery parameters

Mass Energy Density	100-180 Wh/kg	Self-Discharge Rate	1-5% / month
Volume Energy Density	200-300 Wh/L	Cycle Durability	500-15000 cycles
Power Density	1000-5000 W/kg	Typical Cost	\$0.50-\$2.50/Wh
Charge/Discharge Efficiency	95-99%	Self-Discharge Rate	1-5% / month
Mass Energy Density	100-180 Wh/kg		

Hybrid Nickel-Metal (NiMH) Batteries



NiMH batteries are more widely used by hybrid-electric vehicles (HEV), but are also used successfully in some BEV cars. This type of hybrid electric car battery does not get power from outside (can be recharged from an outside source of the car system). The recharging of hybrid electric car batteries depends on engine speed, wheels and regenerative braking.

NiMH batteries have a longer life cycle than lithium-ion batteries or SLA batteries. NiMH batteries are safe and tolerant of incorrect usage. The biggest disadvantages of NiMH batteries include:

- The price is relatively more expensive
- High self-discharge rate
- Generate significant heat at high temperatures.

These deficiencies make NiMH less effective as a battery for electric cars whose batteries must be able to be recharged from outside the system, such as from the PLN network. That is why the car battery is the most widely applied by hybrid cars.

NiMH battery parameters

NiMH Battery Parameters

Mass energy density	40-120 Wh/kg	Self-discharge rate	~30% / month
Volume energy density	140-400 Wh/L	Cycle durability	500-1000 cycles
Power density	300-1000 W/kg	Typical cost	\$0.30-\$0.60/Wh
Efficiency	65-80%		

Lead-Acid (SLA) Batteries

SLA (lead-acid) batteries are the oldest rechargeable batteries. Compared to lithium and NiMH batteries, lead-acid batteries do lose capacity and are much heavier, but the price is relatively cheap and safe. There are large capacity SLA electric car batteries under development, but SLA batteries are now only used by commercial vehicles as a secondary storage system.

Lead-acid battery parameters

Lead-acid Battery Parameters

Mass energy density	30-40 Wh/kg	Self-discharge rate	3-20% / month
Volume energy density	60-75 Wh/L	Cycle durability	500-800 cycles
Power density	180 W/kg	Typical cost	\$0.15-\$0.30/Wh
Efficiency	70-92%		

Ultra-capacitor Batteries



The ultra-capacitor battery is not like the general definition of a battery. In contrast to other electro-chemical batteries, this type of electric vehicle battery actually stores polarized liquid between the electrode and the electrolyte. As the surface area of the liquid increases, the energy storage capacity also increases. Like SLA batteries, ultra-capacitor batteries are very suitable as secondary storage devices in electric vehicles. This is because the ultra-capacitor helps electro-chemical batteries increase their load levels. In addition, ultra-capacitor can provide extra power to electric vehicles during acceleration and regenerative braking.

ZEBRA Batteries



The battery for ZEBRA electric cars is a low-temperature variant of sodium-sulfur (NaS) batteries and is a development of ZEBRA (originally “Zeolite Battery Research Africa” then became a “Zero Emissions Batteries Research Activity” battery) in 1985. From the beginning ZEBRA batteries were indeed developed for electric vehicle applications. The battery uses NaAlCl_4 with Na^+ -beta-alumina ceramic electrolyte.

Characteristics of ZEBRA batteries

- High power cell so that it fits as an electric car battery
- High temperature batteries operate at more than 270°C
- The chemical Sodium Nickel Chloride (NaNiCl) provides a nominal operating cell voltage of 2.58 Volts

Fuel Cell Electric Vehicles

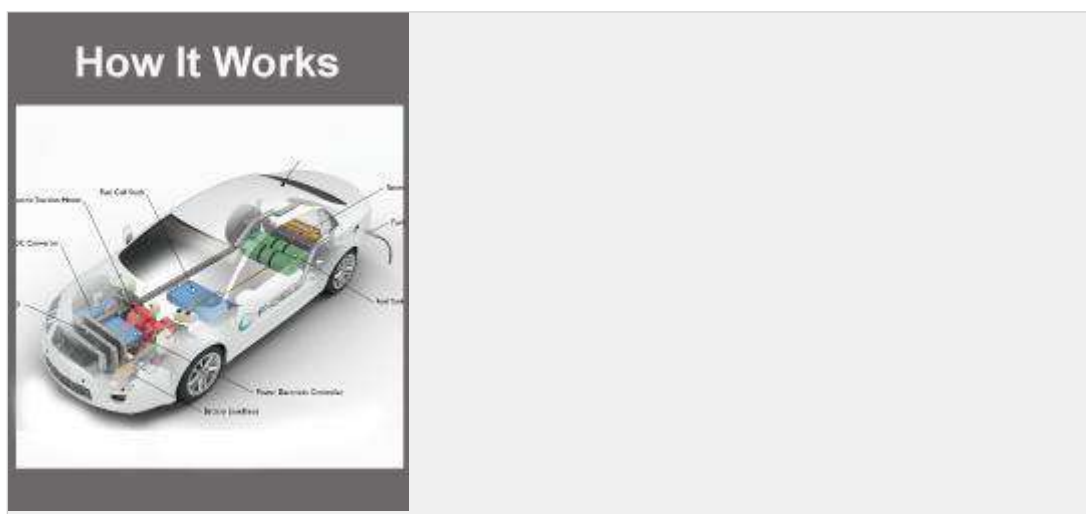

Fuel cell electric vehicles (FCEVs) are powered by hydrogen. They are more efficient than conventional internal combustion engine vehicles and

produce no tailpipe emissions—they only emit water vapor and warm air. FCEVs and the [hydrogen infrastructure](#) to fuel them are in the early stages of implementation. The U.S. Department of Energy leads [research efforts](#) to make hydrogen-powered vehicles an affordable, environmentally friendly, and safe transportation option. Hydrogen is considered an alternative fuel under the [Energy Policy Act of 1992](#) and qualifies for alternative fuel vehicle [tax credits](#).

Fuel cell electric vehicle

FCEVs use a propulsion system similar to that of electric vehicles, where energy stored as hydrogen is converted to electricity by the fuel cell. Unlike conventional internal combustion engine vehicles, these vehicles produce [no harmful tailpipe emissions](#). Other [benefits](#) include increasing U.S. energy resiliency through diversity and strengthening the economy.

FCEVs are fueled with pure hydrogen gas stored in a tank on the vehicle. Similar to conventional internal combustion engine vehicles, they can fuel in [less than 4 minutes](#) and have a driving range over 300 miles. FCEVs are equipped with other advanced technologies to increase efficiency, such as regenerative braking systems that capture the energy lost during braking and store it in a battery

6.4 Hybrid vehicles, Types of Hybrid and Electric Vehicles: Parallel, Series, Parallel and Series configurations

Hybrid electric vehicles are powered by an internal combustion engine and an electric motor, which uses energy stored in [batteries](#). A hybrid electric vehicle cannot be plugged in to charge the battery. Instead, the battery is charged through regenerative braking and by the internal combustion engine. The extra power provided by the electric motor can

potentially allow for a smaller engine. The battery can also power auxiliary loads and reduce engine idling when stopped. Together, these features result in better fuel economy without sacrificing performance. [Learn more about hybrid electric vehicles.](#)

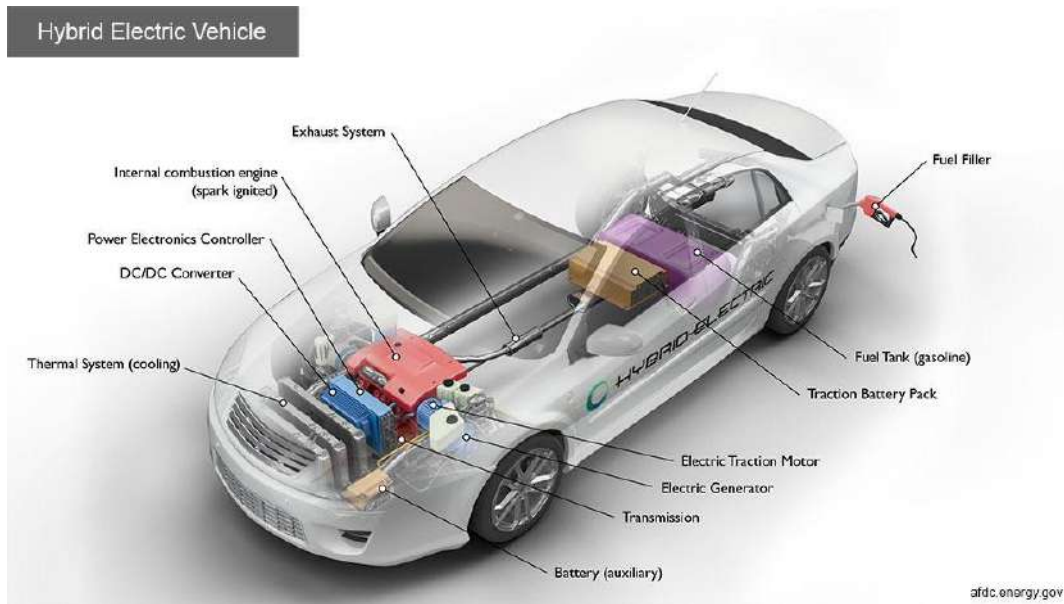

Key Components of a Hybrid Electric Car

Battery (auxiliary): In an electric drive vehicle, the low-voltage auxiliary battery provides electricity to start the car before the traction battery is engaged; it also powers vehicle accessories.

DC/DC converter: This device converts higher-voltage DC power from the traction battery pack to the lower-voltage DC power needed to run vehicle accessories and recharge the auxiliary battery.

Electric generator: Generates electricity from the rotating wheels while braking, transferring that energy back to the traction battery pack. Some vehicles use motor generators that perform both the drive and regeneration functions.

Electric traction motor: Using power from the traction battery pack, this motor drives the vehicle's wheels. Some vehicles use motor generators that perform both the drive and regeneration functions.

Exhaust system: The exhaust system channels the exhaust gases from the engine out through the tailpipe. A three-way catalyst is designed to reduce engine-out emissions within the exhaust system.

Fuel filler: A nozzle from a fuel dispenser attaches to the receptacle on the vehicle to fill the tank.

Fuel tank (gasoline): This tank stores gasoline on board the vehicle until it's needed by the engine.

Internal combustion engine (spark-ignited): In this configuration, fuel is injected into either the intake manifold or the combustion chamber, where it is combined with air, and the air/fuel mixture is ignited by the spark from a spark plug.

Power electronics controller: This unit manages the flow of electrical energy delivered by the traction battery, controlling the speed of the electric traction motor and the torque it produces.

Thermal system (cooling): This system maintains a proper operating temperature range of the engine, electric motor, power electronics, and other components.

Traction battery pack: Stores electricity for use by the electric traction motor.

Transmission: The transmission transfers mechanical power from the engine and/or electric traction motor to drive the wheels.

The type of HEV is determined by how the powertrain propels the vehicle down the road and may be considered either series, parallel, or series-parallel.

Energy Flow Diagrams and Descriptions

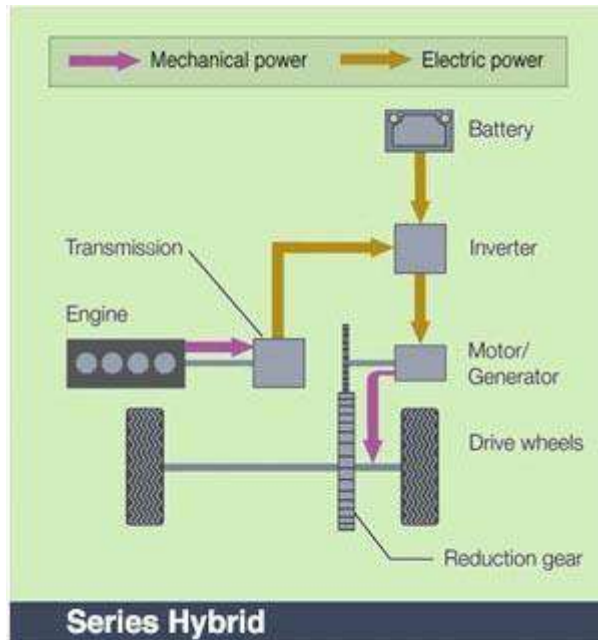

Series (Extended-Range) Hybrid

A series hybrid is like a battery electric vehicle (BEV) in design. Here, the combustion engine drives an electric generator instead of directly driving the wheels. The generator both charges a battery and powers an electric motor that moves the vehicle. When large amounts of power are required, the motor draws electricity from both the battery and the generator. Series hybrids may also be referred to as extended-range electric vehicles (EREVs) or range-extended electric vehicles (REEVs) since the gas engine only generates electricity to be used by the electric motor and never directly drives the wheels. Modern examples include the Cadillac ELR, Chevrolet Volt, and Fisker Karma.

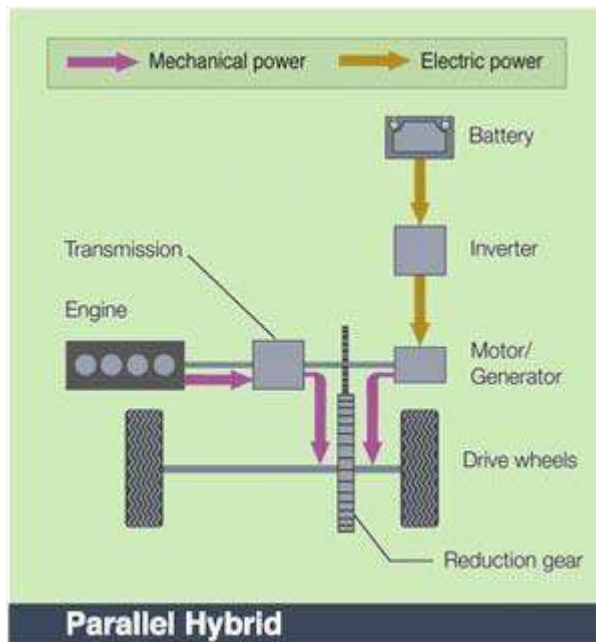

Parallel Hybrid

A parallel hybrid is propelled by both an internal combustion engine (ICE) and an electric motor connected to a mechanical transmission. Power distribution between the engine and the motor is varied so both run in their optimum operating region as much as possible. There is no separate generator in a parallel hybrid. Whenever the generator's operation is needed, the motor functions as generator. In a parallel mild hybrid, the vehicle can never drive in pure electric mode. The electric motor turns on only when a boost is needed.

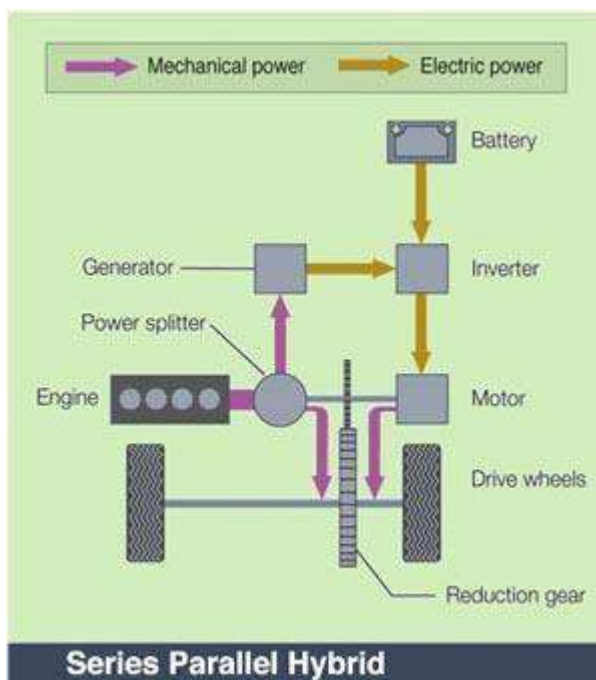

Series-Parallel

The vehicle can be powered by the gasoline engine working alone, the electric motor by itself, or by both energy converters working together. Power distribution between the engine and motor is designed so that the engine can run in its optimum operating range as much as possible.

Note: All configurations above may use more than one motor to drive the vehicle.

6.5 Drive train

A drivetrain is the collection of components that deliver power from a vehicle's engine or motor to the vehicle's wheels. In hybrid-electric cars, the drivetrain's design determines how the electric motor works in conjunction with the conventional engine. The drivetrain affects the vehicle's mechanical efficiency, fuel consumption, and purchasing price.

Hybrids that use a series drivetrain only receive mechanical power from the electric motor, which is run by either a battery or a gasoline-powered generator. In hybrids with parallel drivetrains, the electric motor and internal combustion engine can provide mechanical power simultaneously. Series/parallel drivetrains enable the engine and electric motor to provide power independently or in conjunction with one another.

Both [conventional hybrids](#) and [plug-in hybrids](#) have models with series, parallel, and series/parallel drivetrains. Since [battery-electric](#) and [hydrogen fuel cell vehicles](#) don't have internal combustion engines, they utilize different drivetrain assemblies.

6.6 Solar powered vehicles

Battery recharging and range issues have been the Achilles heel of electric vehicles. Some automotive engineers believe solar power may be the solution.

The goal of vehicle-integrated photovoltaics is to enable EVs to recharge without stopping. Unlike traditional EVs that must periodically pull over to recharge batteries during a long road trip, solar cars can keep on going.

Electric cars and trucks embedded with photovoltaic cells can convert energy from sunlight into electricity. Storing solar energy in batteries enables them to run smoothly at night or in the absence of direct sunlight.

Several start-ups, such as Aptera Motors, Atlis Motor Vehicles, Fisker Inc., Lightyear One and Sono Motors, as well as established OEMs like Hyundai, Tesla and Toyota, are developing solar cars or hybrid versions of them. They are integrating solar cells into roofs. However, other body parts, such as doors, hoods, tailgates and trunks, are also prime real estate.

"Automotive solar panels are a very interesting topic, because the technology can enable electric vehicles to recharge up to 40 percent faster," says Peter Harrop, Ph.D., chairman of IDTechEx, a market research firm that recently published a report on the subject. "Some cars have up to 7 square meters of space available for solar panels.

"The technology has already been successfully used on everything from boats to satellites," notes Harrop. "Any car or truck manufacturer that is not considering solar panel bodywork is crazy."

Solar panels can be attached to vehicle bodies using mechanical fasteners or structural adhesives. However, to be aerodynamic and aesthetically pleasing, automotive engineers prefer to integrate solar modules into body panels.

"While it may be possible to use flexible film in the future, solar panels are not simply stuck onto vehicles today," explains Harrop. "To achieve the complex shapes needed for car bodies, thin solar cells must be molded into carbon fiber, glass or polycarbonate sheets. They become less like traditional solar panels, because they are actually structural elements."

As an example, Harrop points to Lightyear One, a Dutch company that plans to launch a “long-range solar electric vehicle designed to be grid independent” later this year. It will feature 5 square meters of integrated solar cells protected by double-curved and super-strong safety glass.

The solar roof will capture sunlight continually whether the car is moving or stationary. Lightyear One claims that feature will deliver enough energy to cover an average of more than 70 percent of annual mileage.

A conductive backsheet produced by Royal DSM is an integral element of Lightyear One’s solar roof. It enables all the connections of the solar cells to be put on the back of the solar panel, which makes every available centimeter on the front of the module available for capturing sunlight.

“The reduction in electrical (cell-to-module) losses not only delivers a 3 percent increase in power output; it has the added advantage of contributing to a more stylish sunroof with aesthetic appeal,” claims Pascal de Sain, vice president of DSM Advanced Solar.

Another solar roof concept was recently developed by engineers at Teijin Ltd. It uses the company’s Panlite polycarbonate resin glazing for its surface.

“[We molded] the roof’s curved surface into an ideal shape, an extremely challenging process in the case of using glass,” says Toshiaki Hotaka, general manager of Teijin’s mobility division. “Not only is the roof ideally shaped, it achieves the strength and rigidity required for the [application.]”

The Teijin solar roof was installed on a prototype from Applied Electric Vehicles. During tests conducted in Australia, it achieved output of about 330 watts, which is equivalent to a conventional solar panel housed under glass.

Numerous Benefits

“The benefit of solar-powered vehicles is that they don’t require fuel and have a low cost of maintenance,” says Lex Hoefsloot, CEO of Lightyear One. “Solar cars run longer on the same battery. This requires less charging stops and will get you faster from point A to point B. Solar energy will never run out and it is free.

“Because the pressure on the grid from solar cars is far less, they offer the potential to truly scale clean mobility,” explains Hoefsloot. “From a user perspective, all you need is a regular power outlet combined with the sun; no need to wait for charging infrastructure, again creating a scalable solution.”

Hoefsloot claims that Lightyear One will “consume two to three times less energy than any other electric vehicle on the market today, which results in an exceptional range of 725 kilometers.” However, the overall achievable yield strongly depends on the driving patterns of individuals.

“[Our vehicle] has around 1,000 individual solar cells across the car that ultimately add 50 to 70 kilometers of range per day during summer,” Hoefsloot points out. “[Our solar modules] can charge the car’s battery with up to 12 kilometers of range an hour. These solar cells are 20 percent more efficient than the solar panels you can buy for your home. And, they’re encased in safety glass to protect them from damage.

“We will outsource the production of our vehicles,” says Hoefsloot. “We are currently talking to [several] potential production partners...in Europe.”

“The power that can potentially be generated on a car roof has increased substantially, due to the continuous improvement of solar cell and solar module technology, leading to higher efficiency,” adds Martin Heinrich, Ph.D., head of the department of module technology at the photovoltaics division of the Fraunhofer Institute for Solar Energy Systems. “Therefore, not only a cooling of the passenger cabin could be provided by the solar roof, but even a significant extension of the driving distance could be feasible.”

According to Heinrich, both transparent and opaque photovoltaics can be used for automotive applications. “But, since the available area on vehicles is quite small, we would rather use as much irradiation as possible for power generation instead of receiving light in the vehicle,” he explains.

“Opaque PV works better and offers higher power output, and therefore generates a larger solar range,” says Heinrich. “If transparency is required (such as a sun roof or rear window), transparent solar cell technology can be used, but it currently has a significantly lower power output.”

Heinrich and his colleagues are working on several projects involving solar panel integration into roofs and hoods for passenger cars, including efficient connection to the vehicle power management system. They're also developing module technology for box bodies on trucks that can be integrated into bodywork seamlessly, without any parts sticking out.

Engineering Challenges

Despite tremendous potential, equipping a vehicle with solar panels presents numerous challenges to automotive engineers. According to Heinrich, there are three big challenges:

- Making the most of the generated energy. Battery charging losses due to self-consumption or charging status where the battery is full but solar power can still be generated must be addressed.
-
- Manufacturing safe, reliable and cost-effective modules for vehicle integration.
-
- The reduction of power generation by bad weather and shadowing by other vehicles, in addition to buildings, bridges, trees and tunnels. "This cannot be avoided, but prediction models would provide better estimates for yield calculations and charging optimization," explains Heinrich.
-

"There are solutions available to those challenges, but in most cases, they are still being studied," says Heinrich. "The main technological challenge is the utilization of the generated power. For a high utilization, the high-voltage drivetrain battery is preferred. However, this could lead to significant transformation losses and potentially safety concerns."

Further challenges arise due to the curvature of car roofs. For instance, a strong curvature may lead to a significant irradiance mismatch and resulting cell power, which could reduce the yield of the solar module. In addition, module and cell technology needs to provide the highest yield, but also a premium aesthetic appearance and durability.

“The challenge with integrating solar cells into an electric vehicle is to maximize the surface area, making sure you achieve automotive-grade standards for reliability and safety, while still optimizing the total performance,” says Arjo van der Ham, chief technology officer at Lightyear One. “Integrating the cells on a double curved surface ensures a great aerodynamic performance of the vehicle, but also creates a challenge in optimizing the yield.

“Normally solar cells are put in series,” explains van der Ham. “In that case, the part in the shadow will reduce the yield of the total panel.

“We have developed proprietary and highly efficient solar electronics to compensate for this loss,” adds van der Ham. “[It enables us] to put groups of cells in parallel. We have also performed many types of impact, heat and vibration tests.”

Another startup firm that has been studying the pros and cons of solar power is Atlis Motor Vehicles Inc. The company is getting ready to produce an electric pickup truck at a new factory in Mesa, AZ. Its innovative XT model, which is aimed at commercial users, will be equipped with a solar panel tonneau cover system called TerraVis.

“We believe there can be a role for solar to play on a full-size truck like ours,” says Mark Hanchett, CEO of Atlis Motor Vehicles. “There are ancillary functions where we feel solar could offer some advantages.

“One example is climate control, especially in hot climates where the sun is high,” notes Hanchett. “Even getting a couple hundred watts from a small solar array may be enough to run fans to provide circulation of air into the cab to avoid the 140 to 160 F peaks that are possible during the summer. Another possible use for on-board solar is for long-term storage, to compensate for parasitic or ‘vampire’ drains on the battery.

“Even in a much shorter term, like during the day on a job site, solar may be able to keep the battery at a consistent level while using power tools or chargers powered from the truck’s on-board power inverter,” Hanchett points out. “For these tasks and more, a smaller set of panels able to make 250 to 500 watts of power would be sufficient.

“The problem comes down to the energy density of solar,” warns Hanchett. “Simply put, only so much energy from the sun is available per

square meter, and solar panels can only capture a portion of that energy. Further complications arise from the orientation of the panels.

“[Unlike solar panels on homes], vehicles really only have horizontal surfaces to work with, and they are at a very flat angle, which is not the most optimal for making power,” says Hanchett. “And, parking in partial shade near a tree may also mean that a certain panel can’t make enough power, which can affect the output of the whole array.”

Let the Sun Shine

Several solar-powered cars are currently available, with others on the horizon. Last year, Hyundai Motor Co. unveiled a hybrid version of its popular Sonata sedan that is equipped with a roof-mounted system. It consists of a solar panel and controller that enable the vehicle to generate and store electricity in a battery.

According to Hyundai, the system can charge 30 percent to 60 percent of the battery per day, which can increase the vehicle’s travel distance by an extra 1,300 kilometers annually.

Several startup companies are also jumping on the solar car bandwagon.

Later this year, Aptera Motors Corp. plans to begin mass-producing a three-wheeled solar vehicle at its factory in San Diego. Its carbon-fiber composite body will be covered in 3 square meters of solar cells. The company claims that at least 90 percent of the power produced by the solar panels will go toward propelling the vehicle.

“Integrated solar can be configured to provide up to 45 miles of range per day,” claims Chris Anthony, CEO of Aptera Motors. “[This will be the] first vehicle capable of meeting most daily driving needs using solar power alone.

“Our built-in solar array keeps the battery pack topped off,” explains Anthony. “Never Charge technology is built into every vehicle and is designed to harvest enough sunlight to travel over 11,000 miles per year in most regions.”

Sono Motors is a German start-up company that plans to ramp up production of its Sion vehicle in 2023 at a former Saab plant in Trollhättan, Sweden. Sono's proprietary technology replaces traditional paint with integrated solar panels.

"Solar modules are worked seamlessly into the surface of the body parts to supply vehicles with electricity," says Mathieu Baudrit, director of photovoltaic integration at Sono Motors. "Drawing on the power of the sun, [our] system will be able to provide energy for an additional range of up to 245 kilometers a week.

"We have found a way to deliver sustainable, free power across various transportation applications by replacing the traditional paint shop process with integrated solar technology," claims Baudrit. "[Our] solar technology is cheaper, lighter and much more efficient than conventional glass-based solar cells. With a boundless range of potential applications, [it] is a seamless, flexible solution for efficient electric charging.

"We wanted to develop a vehicle that can harvest the maximum amount of energy from the sun," explains Baudrit. "Current technologies available on the market are based on glass photovoltaics, only allowing solar cells to integrate on flat surfaces such as the roof. Having solar cells only on the roof will not harvest the maximum solar energy throughout the entire year, because the sun is lower in the sky during winter.

"We had to create a whole new manufacturing process to integrate the solar cells on the vehicle body, based on injection molding," says Baudrit. "Injection molding is a manufacturing process which allows us to make complex shaped parts out of polymers. It is a very fast manufacturing process, allowing low scrap rate and many different applications.

"[This enables us to] achieve a seamless integration of the photovoltaic function into the car body panels," adds Baudrit. "It is flexible in the sense that we can shape the PV function to the form of the host vehicle as robust as conventional polymer car body panels and cheaper. Thanks to the injection molding process, we remove the need for curved glass.

"We are planning to integrate more than 248 solar cells into the Sion, with a target of having 1.2 kWp of solar cells installed on the vehicle," Baudrit points out. "The solar panels are the body panels. The solar

panels will be integrated into the hood, fenders, sides, roof and rear of the vehicle, visually blending into the surface."

THANK YOU