

PNS SCHOOL OF ENGINEERING & TECHNOLOGY

NISHAMANI VIHAR , MARSHAGHAI, KENDRAPARA-754213



SUBJECT-Advanced Construction Techniques & Equipment

6th Semester

Prepared by Er. Santoshi Dipty Prusty

DEPARTMENT OF CIVIL ENGINEERING

Chapter 1: Advanced construction materials

(A) Plastic as Construction Material

Plastic is a general name given to a wide range of synthetic materials that are based on polymers. The construction industry uses plastic for a wide range of applications because of its versatility, strength-to-weight ratio, durability, corrosion resistance, and so on.

Plastic can be manufactured into forms such as; pipes, cables, coverings, panels, films, sheets and so on; and can be formed or expanded to create low-density materials; and be dissolved in solvents.

Some of these plastics main uses in the construction industry are,

- Cladding panels.
- Cables
- Pipes and gutters.
- Windows and doors.
- Shuttering
- Wall linings
- Floor covering
- Ceiling panels.
- Roof coverings.
- Sinks, basins, baths, and showers.

: The advantages of using plastic in construction are that it is lightweight yet strong which makes it easier to transport and shift around sites. It is also resistant to rot and corrosion and has strong weather ability due to it being capable of achieving tight seals.

: The disadvantages of plastic are that it has a high embodied energy content and a low modulus of elasticity, meaning that it is generally unsuitable for load-bearing applications.

PROPERTIES: -

: Typically, construction professionals select plastic materials based on the following criteria:

1. Durability
2. Cost effectiveness
3. Recycling
4. Energy saving
5. Safety
6. Easy to install

Use of Plastics in Different Aspects of the Construction Industry

1. Flooring

Plastic materials like polyvinyl chloride (PVC) and polyethylene are used to make flooring less prone to wear and tear. It also decreases the sound pollution level and can be cleaned easily.

2. Roofing

To protect the outer surface of the roof from damage, two layers of different plastic materials are required. The upper part is made of colored thermoplastic olefin or vinyl while the lower part consists of polyurethane foam which consumes less energy and keeps the interior of a house cooler.

3. Insulation

Polyurethane spray is frequently used for insulation when constructing green or low energy buildings. Rigid polyurethane foam is known for its high thermal resistance which promotes temperature consistency. Polyurethane foam is also popular because it is lightweight, chemical resistant, and flame retardant. Due to its closed cell nature, polyurethane insulation performs as an air barrier, resulting in significant energy savings.

4. Wall

A structural insulated panel (SIP) is a sandwich of expanded polystyrene amidst two slim layers of oriented strand board. This type of pre-fab, composite wall board can be transferred to the work place easily for a particular task and provide good support to columns and other associated essentials during renovation.

5. Pipes

Commonly made up of polyvinyl chloride (PVC), CPVC, acrylonitrile butadiene styrene (ABS) or polyethylene, plastic pipes are flexible and very light in weight, making them easy to install. All of these plastic materials are also highly chemical and water resistant, making them suitable for many extreme environments.

6. Windows

Polycarbonate is used to manufacture building windows. This plastic material is strong, clear and very light in weight. Polycarbonate windows are considered more burglar-proof than regular glass windows. Two plastic materials, vinyl and fiberglass, are used commonly in the production of window frames. Fiberglass is extremely strong while vinyl is quite durable and also inexpensive.

7. Doors

Some construction projects use doors made from a stiff polyurethane foam core with a fiber reinforced plastic (FRP) coating. The sandwich structure of these doors makes them incredibly strong.

TYPES:-

PVC:-

Polyvinyl chloride (PVC), a synthetic resin made from the polymerization of vinyl chloride. Second only to polyethylene among the plastics in production and consumption, PVC is used in an enormous range of domestic and industrial products, from raincoats and shower curtains to window frames and indoor plumbing. A lightweight, rigid plastic in its pure form, it is also manufactured in a flexible "plasticized" form.

RPVC:-

RPVC means Rigid PolyVinyl Chloride which comes from PVC. Polyvinyl chloride (PVC), also known as vinyl, is a common plastic polymer (a polymer being a large molecule). It comes in two basic forms: flexible and rigid (RPVC). RPVC is used in construction (especially pipes), packaging etc. RPVC Pipes with high impact strength & load bearing capacity!

HDPE:-

High density polyethylene (HDPE) piping systems have been used for municipal and industrial water applications for over 50 years. Within Building & Construction Division, HDPE pipes are used for ground source geothermal applications, also known as earth energy or geexchange systems.

FRP:-

Fibre-reinforced plastic (FRP) (also called fiber-reinforced polymer). FRP bars are used as internal reinforcement for concrete structures. FRP bars, sheets, and strips are used for strengthening of various structures constructed from concrete, masonry, timber, and even steel. Fibre reinforced polymers are used in the construction of special structures requiring electrical neutrality.

GRP:-

GRP stands for 'Glass Reinforced Plastic' a material made from a polyester resin, which is reinforced by chopped strand mat glass fibres to form a GRP laminate. It is a very popular composite material to use because not only is it very strong but also surprisingly light.

Coloured Plastic Sheets:-

Plastic film is a thin continuous polymeric material. Thicker plastic material is often called a "sheet". Plastic sheets are generally low cost, easy to manufacture, durable, strong for their weight, electrically and thermally insulative, and resistant to shock, corrosion, chemicals, and water.

(B) FIBER AS A CONSTRUCTION MATERIAL

- Fiber or fibers is a class of material which are having continuous filaments or having discrete elongated pieces similar to the length of thread.
- Fibers are very important in the biology of plants and animals for holding tissue together. They are often used in the manufacture of other materials.
- Fibers can be spun into filaments or string or rope which can be used as a component of composite material or matted into sheets so as to make the products like paper or felt.
- Fibers are inorganic or organic, natural or synthetic. Synthetic fibers can be produced very cheaply and in large amounts as compared to natural fibers. Rayon and nylon are organic synthetic fibers.
- Burlap is a coarse jute or hemp which is a natural fiber. Hessian is a jute fabric. Silk and cotton are produced from natural fibers.
- Glass wool, lead wool and asbestos are mineral fibers of which glass wool and lead wool are synthetic fibers.
- Steel fiber, carbon fiber and glass fiber are the new and recent trends used in the construction work.

General Uses of Fibers

- Fibers are used for packing and making fabrics and felts.
- Glass wool made of very fine fibers of glass is used for making acid-proof and fire-proof fabrics.
- Glass wool is also used as a packing material for heat, sound and electric insulation. It is commonly used in a solar water system.
- Lead wool prepared from fine fibers of lead is used in water pipe joints to stop leakage of water. Natural jute fibers are extensively used in plumbing work to stop leakage of water.

Types of Fibers :

There are mainly three types of fibers which are commonly used as a construction materials.

1. Steel fiber

Steel fiber are made from the cold drawn steel wire with low content of carbon or stainless steel wire. They are manufactured in various types such as hooked steel fibers, undulated or

flat steel fibers according to the need required in the construction project. These fibers are used in the construction for concrete reinforcement. Steel fiber reinforced concrete is less expensive than hand tied re-bar shape, dimensions and length of the fiber are more important because it increases the tensile strength of the concrete.

Steel fibers can only be used on surfaces so as to avoid corrosion and rust stains. Fiber-reinforced normal concrete is mostly used for on-ground floors and pavements and also used for the construction parts such as beams, pillars, foundation etc.

Properties of Steel Fibers

- It increases the tensile strength of concrete.
- It is more tough and hard.
- It avoids corrosion and rust stains.
- They are more elastic in nature.
- Steel fibers are available with standards as ASTM 820/96, ASTM C 1116/95 and DIN 1045.
- It has a tensile strength of 1.100 N/mm².
- They are available in the shapes like flat, hooked and undulated.

Applications of Steel Fibers on Field

- Steel fibers are highly used in tunnel lining work.
- It is mostly used in the construction of airport runways and highway pavements.
- Most commonly used in precast concrete so as to increase the tensile strength.
- They are used in shotcrete.
- Used in the construction of parking.
- It is used in anti-seismic buildings.

2. Carbon fibers

Carbon fiber is a material consisting of extremely thin fibers about 0.005 mm to 0.010 mm in diameter and mostly composed of carbon atoms. Carbon fiber is alternately called graphite fiber. The carbon atoms are bonded together in microscopic crystals which are more or less aligned parallel to the long axis of the fiber. The crystal alignment makes size of fiber more strong. Number of carbon fibers are twisted together so as to form a Yarn which can be used as it exist or woven into a fabric. It can be combined with a plastic resin and wound or moulded to form composite materials like carbon fiber reinforced plastic to provide a high strength to weight ratio of the materials. The atomic structure of carbon fiber is similar to that of graphite consisting of sheets of carbon atoms arranged in a regular hexagonal pattern. Carbon fibers shows the number of properties very close to the properties of asbestos. Each carbon filament thread

is a bundle of many thousand carbon filaments. A single such filament is a thin tube with a diameter of 5-8 μm (i.e. 5-8 micrometres) and consists of almost exclusively of carbon.

Properties of Carbon Fibers

- It has a high tensile strength, low weight and low thermal expansion.
- They are rigid materials which are resistant to stretching and compression.
- It is chemically inert or unreactive materials.
- They are resistant to corrosion.
- Fibers contained about 85% carbon has excellent flexural strength.

Application of Carbon Fibers

- Carbon fiber is mostly used to reinforce composite material.
- Reinforced Carbon-Carbon (RCC) consists of carbon fiber-reinforced graphite and is used structurally in high temperature applications.
- It increases the tensile as well as compressive strength of concrete.
- Due to high tensile strength, low weight and low thermal expansion it makes the carbon fiber very popular in aerospace, military and motorsports along with other competition sports.
- Carbon fiber is extensively used in the bicycle industry, especially for high-performance racing bikes.
- It is also used in some tennis rackets.
- It is now being used in musical instruments for its weather resilience and ability to recreate the tone of guitars.

3. Glass fibers

It is also called as fiber glass. Glass fiber is the material made from extremely fine fibers of glass. It was invented in 1938 by Russell Games Slayter. In 1893, Edward Drummond Libbey exhibited a dress at the World's Calumbian Exposition incorporating glass fibers with the diameter and texture of silk fibers. This was first worn by the well known and popular stage actress of the time Georgia Cayvan. There are two main types of glass fiber manufacture and two main types of glass fiber product. First fiber is made either from a direct melt process or a marble remelt process. Both start with the raw materials in solid form. It is almost and always made of platinum alloyed with rhodium for better durability. Platinum is used because the glass melt has a natural affinity for wetting it. The fresh and thin fibers are more strong because the thinner fibers are more ductile.

Properties of Glass Fibers

- It has high ratio of surface area to weight.
- They have good thermal insulation.
- It has a good tensile strength but has no strength against compression.
- Compressive strength is weak but can be increased by reinforcing it with plastic.

- When the glass fiber is reinforced with plastic, then reinforced material can resist both compressive and tensile forces as well.
- It is resistant to chemical attack. However, if its surface area is increased, then it makes them more susceptible to chemical attack.
- They are corrosion resistant.

Application of Glass Fibers

- Corrugated fiber glass panels are widely used for outdoor canopy or greenhouse construction.
- It is used as a reinforcing agent for many polymer products like FRP and GRP which uses tubs, pipes for drinking water and 'sewers, office plant containers and flat roof systems etc.
- It is reinforced with plastic material so as to increase tensile strength.
- Uses of regular fiber glass are mats, insulation, reinforcement sound absorption, heat resistance fabrics, corrosion resistant fabrics and high strength fabrics.
- Glass fiber reinforced plastics are used in the house building market for the production of roofing laminate, door surrounds, over-door canopies, window canopies and dormers, chimneys, coping system, heads with keystone and sill etc.
- The reinforced glass fiber with polymer and plastic is commonly used in fire water systems, cooling water systems, drinking water systems, sewage systems, waste water systems, gas system etc.

(B) ARTIFICIAL TIMBER

Reduction of moisture content along with improving some qualities before the use of woods is called seasoning of timber. By seasoning, generally, the moisture is reduced to about 15% where new cut woods bear about 50%.

Reasons for Seasoning

Seasoning of timber is done to fulfill some specific requirement. Followings are the reasons to perform timber seasoning.

1. To change and improve the properties of wood.
2. To make a correct percentage of shrinking of woods.
3. To make a confident use of woods.
4. To reduce the adverse behaviour of woods.

Methods of Seasoning of Timber

There are mainly two methods of seasoning of timber. These are:

A) Natural Seasoning

B) Artificial Seasoning

Following tree diagram can be used to illustrate all the methods of timber seasoning.

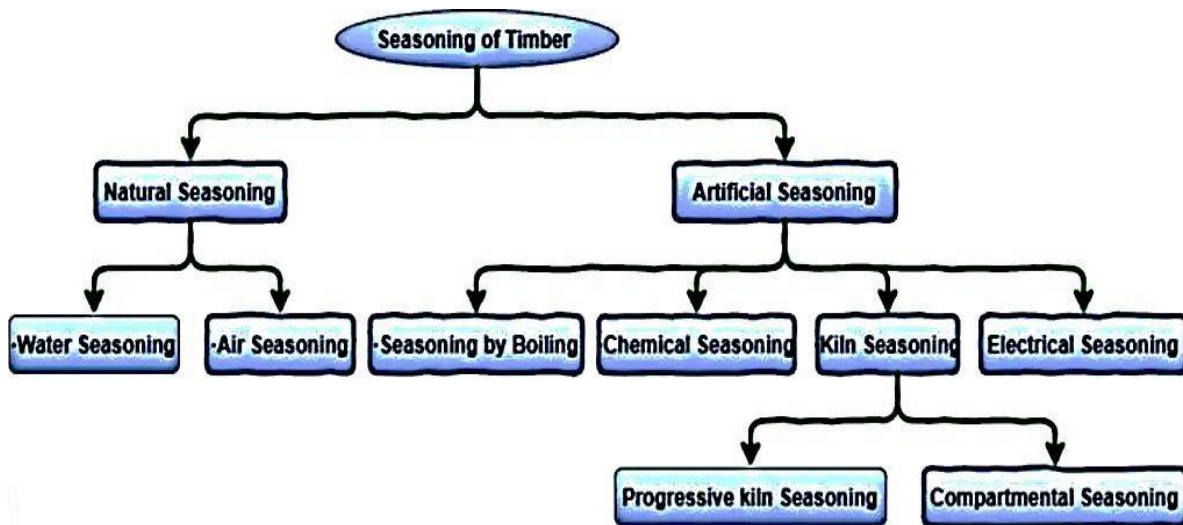

Natural Seasoning

Seasoning of woods or timbers using natural elements is called natural seasoning. eg. water and air seasoning.

a. Water seasoning

Removal of wood sap immersing logs into water flow is called water seasoning. It is carried out on the banks of the river while thicker ends are kept towards upstream. After that, the logs are allowed to dry. Disadvantage: It is time consuming such as 2 to 4 weeks generally.

b. Air seasoning

Exposing the woods to air for seasoning. At first, a platform is required that is built on the ground at 300mm height above the ground.

Secondly, the arrangement of woods in layers. Air circulation is maintained between logs because it helps to reduce the moisture which is important for seasoning. The environment for this need to maintain some conditions. A clean, shady, dry, cool place is preferred. Sometimes logs are coated by the impermeable substance to reduce extreme moisture. To improve the quality oil coating,

thick paint coating is maintained. To prevent fungal infection logs are treated with petrol or gasoline.

Advantage:

- Good quality of seasoned wood.
- A large amount is convenient in this process.
- Well-seasoned timber is formed.

Disadvantage:

- It's a slow process.

Artificial Seasoning

a. Seasoning by Boiling

Seasoning by boiling wood logs in hot water is called seasoning by boiling. Drying is done after proper boiling. For a large amount of wood, it is done in an enclosed place where hot steam is passed.

Advantages

- It takes a short amount of time. Generally, 3-4 hours is good enough. Develops the strength and elasticity.

Disadvantages

- It is serviceable basically for a small quantity of wood, not convenient for a large amount. The cost is high.

b. Chemical seasoning

Reduction of moisture using salt solution is called chemical seasoning. After the absorption of water by the solution logs are let to dry.

Advantage

- It increases the strength of the timber.
- It is less time-consuming.

Disadvantage

- Chemical reagents can sometimes reduce strength.
- It can cause a problem in gluing or finishing or corrosion while using.

c. Kiln seasoning

Seasoning of wood by using a large chamber or oven where there is a good process for the circulation of hot air.

Advantage

Most effective and economic seasoning.

Kiln seasoning can be done by 2 processes such as: -

- Progressive kiln Seasoning: Wood log is entered through the kiln and the temperature and humidity differentials are maintained through the length of the kiln to maintain proper drying.
- Compartmental Seasoning: It's maintained by enclosed container or buildings.
Advantage: It accelerates the process because external energy is used.

d. Electrical seasoning

Dry wood is non-conductor of electricity while green timber is a conductor, so, can pass alternating current. Thus, in this method alternating current is used for the resistance of timber against electricity is measured at every interval of time. When the required resistance is reached seasoning, process is stopped because resistance of timber increases by reducing moisture content in it. It is also called as rapid seasoning and it is uneconomical.

(C) Miscellaneous Materials.

A category of asbestos-containing building material comprised mostly of nonfriable asbestos products and materials, such as ceiling tiles, floor tiles, roofing felt, transit pipes and panels, exterior siding, fabrics, and sheetrock systems.

- **Acoustics Material**

When the sound intensity is more, then it gives the great trouble or nuisance to the particular area like auditorium, cinema hall, studio, recreation centre, entertainment hall, college reading hall. Hence it is very important to make that area or room to be sound proof by using a suitable material called as 'Acoustic material'. It is measured in decibels (db).

Properties of Acoustic Material

- Sound energy is captured and adsorbed.
- It has a low reflection and high absorption of sound.
- Higher density improves the sound absorption efficiency at lower frequencies.
- Higher density material help to maintain a low flammability performance. Hence acoustic material should have higher density.
- It controls the sound and noise levels from machinery and other sources for environmental amelioration and regulatory compliance.
- Acoustic material reduces the energy of sound waves as they pass through.
- It suppresses echoes, reverberation, resonance and reflection.

Uses of Acoustic Material

- Acoustic materials can be used for noise reduction and noise absorption. It makes the sound more audible which is clear to listen without any disturbances.
- 2. It suppresses echoes, reverberation, reflection and resonance.
- Important specifications for noise reduction and noise absorption products include noise attenuation and noise reduction coefficient.
- 4. A vinyl acoustic barrier blocks controls airborne noise (street traffic, voices, music) from passing through a wall ceiling or floor.

- 5. Acoustic foam and acoustic ceiling tiles absorb sound so as to minimize echo and reverberation within a room.
- 6. Sound proof doors and windows are designed to reduce the transmission of sound.
- A sound proof wall (treated by a accurate material) can incorporate sound proofing and acoustic materials to meet desired sound transmission class (STC) values.

Wall cladding



Wall cladding is a type of decorative covering intended to make a wall look like it is made of a different sort of material than it actually is. Some of the most common examples are on the outside of buildings, but cladding can also be an artistic element in interior decorating.

The most common types of cladding are Stone Cladding, Brick Cladding, Timber Cladding, Metal Cladding, Concrete Cladding, Glass Cladding.

Plasterboard



Plasterboard is a panel made of calcium sulphate dihydrate (gypsum) usually pressed between a facer and a backer. It is used to make interior walls and ceilings. This 'Drywall' construction became popular as a quicker alternative to traditional lath application.

Microsilica



Micro silica or silica fume is an excellent admixture for concrete as it leads to better engineering properties. It reduces thermal cracking, improves durability, and increases strength. Silica fume concrete has a number of construction applications.

Artificial Sand



Artificial sand, also called crushed sand or mechanical sand, refers to rocks, mine tailings or industrial waste granules with a particle size of less than 4.75 mm, which are processed by mechanical crushing and sieving, but does not include soft and weathered granules.

Bonding Agents



Bonding agents are natural, compounded or synthetic materials used to enhance the joining of individual members of a structure without employing mechanical fasteners. The most commonly used types of bonding agents are generally made from natural rubber, synthetic rubber or from any

other organic polymers. The polymers include polyvinyl chloride, polyvinyl acetate etc. With the addition of bonding agent in repair mortar or concrete, the reduced water-cement ratio can be adopted for the same workability, thereby reducing drying shrinkage.

Adhesive



Construction adhesive is a general-purpose adhesive used for attaching drywall, tile, moulding, and fixtures to walls, ceilings, and floors. It is most commonly available in tubes intended for use.

MODULE-2

PREFABRICATION

Prefabrication is the practice of assembling components of a structure in a factory or other manufacturing site, and transporting complete assemblies or sub-assemblies to the construction site where the structure is to be located. The term is used to distinguish this process from the more conventional construction practice of transporting the basic materials to the construction site where all assembly is carried out.

The term prefabrication also applies to the manufacturing of things other than structures at a fixed site. It is frequently used when fabrication of a section of a machine or any movable structure is shifted from the main manufacturing site to another location, and the section is supplied assembled and ready to fit. It is not generally used to refer to electrical or electronic components of a machine, or mechanical parts such as pumps, gearboxes and compressors which are usually supplied as separate items, but to sections of the body of the machine which in the past were fabricated with the whole machine. Prefabricated parts of the body of the machine may be called 'sub-assemblies' to distinguish them from the other components.

History

Prefabrication has been used since ancient times. For example, it is claimed that the world's oldest known engineered roadway, the Sweet Track constructed in England around 3800 BC, employed prefabricated timber sections brought to the site rather than assembled on-site.[citation needed]

Sinhalese kings of ancient Sri Lanka have used prefabricated buildings technology to erect giant structures, which dates back as far as 2000 years, where some sections were prepared separately and then fitted together, specially in the Kingdom of Anuradhapura and Kingdom of Polonnaruwa.

After the great Lisbon earthquake of 1755, the Portuguese capital, especially the Baixa district, was rebuilt by using prefabrication on an unprecedented scale. Under the guidance of Sebastião José de Carvalho e Melo, popularly known as the Marquis de Pombal, the most powerful royal minister of D. Jose I, a new Pombaline style of architecture and urban planning arose, which introduced early anti-seismic design features and innovative prefabricated construction methods, according to which large multistory buildings were entirely manufactured outside the city, transported in pieces and then assembled on site. The process, which lasted into the nineteenth century, lodged the city's residents in safe new structures unheard-of before the quake.

Also in Portugal, the town of Vila Real de Santo António in the Algarve, founded on 30 December 1773, was quickly erected through the use of prefabricated materials en masse. The first of the prefabricated stones was laid in March 1774. By 13 May 1776, the centre of the town had been finished and was officially opened.

In 19th century Australia a large number of prefabricated houses were imported from the United Kingdom.

The method was widely used in the construction of prefabricated housing in the 20th century, such as in the United Kingdom as temporary housing for thousands of urban families "bombed out" during World War II. Assembling sections in factories saved time on-site and the lightness of the panels reduced the cost of foundations and assembly on site. Coloured concrete grey and with flat roofs, prefab houses were uninsulated and cold and life in a prefab acquired a certain stigma, but some London prefabs were occupied for much longer than the projected 10 years.[1]

The Crystal Palace, erected in London in 1851, was a highly visible example of iron and glass prefabricated construction; it was followed on a smaller scale by Oxford Rewley Road railway station.

Current uses



A house being built with prefabricated concrete panels.

The most widely used form of prefabrication in building and civil engineering is the use of prefabricated concrete and prefabricated steel sections in structures where a particular part or form is repeated many times. It can be difficult to construct the formwork required to mould concrete components on site, and delivering wet concrete to the site before it starts to set requires precise time management. Pouring concrete sections in a factory brings the advantages of being able to re-use moulds and the concrete can be mixed on the spot without having to be transported to and pumped wet on a congested construction site. Prefabricating steel sections reduces on-site cutting and welding costs as well as the associated hazards.

Prefabrication techniques are used in the construction of apartment blocks, and housing developments with repeated housing units. The quality of prefabricated housing units has increased to the point that they may not be distinguishable from traditionally built units to those that live in them. The technique is also used in office blocks, warehouses and factory buildings. Prefabricated steel and glass sections are widely used for the exterior of large buildings.

Detached houses, cottages, log cabin, saunas, etc. are also sold with prefabricated elements. Prefabrication of modular wall elements allows building of complex thermal insulation, window frame components, etc. on an assembly line, which tends to improve quality over on-site construction of each individual wall or frame. Wood construction in particular benefits from the improved quality. However, tradition often favors building by hand in many countries, and the image of prefab as a "cheap" method only slows its adoption. However, current practice already allows the modifying the floor plan according to the customer's requirements and selecting the surfacing material, e.g. a personalized brick facade can be masoned even if the load-supporting elements are timber.

Transportation of prefabricated Airbus wing assembly

Prefabrication saves engineering time on the construction site in civil engineering projects. This can be vital to the success of projects such as bridges and avalanche galleries, where weather conditions may only allow brief periods of construction. Prefabricated bridge elements and systems offer bridge designers and contractors significant advantages in terms of construction time, safety, environmental impact, constructibility, and cost. Prefabrication can also help minimize the impact on traffic from bridge building. Additionally, small, commonly used structures such as concrete pylons are in most cases prefabricated.

Radio towers for mobile phone and other services often consist of multiple prefabricated sections. Modern lattice towers and guyed masts are also commonly assembled of prefabricated elements.

Prefabrication has become widely used in the assembly of aircraft and spacecraft, with components such as wings and fuselage sections often being manufactured in different countries or states from the final assembly site. However, this is sometimes for political rather than commercial reasons, such as for Airbus.

Process and theory

An example from house-building illustrates the process of prefabrication. The conventional method of building a house is to transport bricks, timber, cement, sand, steel and construction aggregate, etc. to the site, and to construct the house on site from these materials. In prefabricated construction, only the foundations are constructed in this way, while sections of walls, floors and roof are prefabricated (assembled) in a factory (possibly with window and door frames included), transported to the site, lifted into place by a crane and bolted together.

Prefabrication is used in the manufacture of ships, aircraft and all kinds of vehicles and machines where sections previously assembled at the final point of manufacture are assembled elsewhere instead, before being delivered for final assembly.

The theory behind the method is that time and cost is saved if similar construction tasks can be grouped, and assembly line techniques can be employed in prefabrication at a location where skilled labour is available, while congestion at the assembly site, which wastes time, can be reduced. The method finds application particularly where the structure is composed of repeating units or forms, or where multiple copies of the same basic structure are being constructed. Prefabrication avoids the need to transport so many skilled workers to the construction site, and other restricting conditions such as a lack of power, lack of water, exposure to harsh weather or a hazardous environment are avoided. Against these advantages must be weighed the cost of transporting prefabricated sections and lifting them into position as they will usually be larger, more fragile and more difficult to handle than the materials and components of which they are made.

Types of prefabricated systems

There are two main types of prefabrication, namely volumetric (often referred to as 'modular') and panellised. Both of these types of construction can be achieved in timber, steel and concrete, and can also be mixed within the same scheme.

Steel systems for housing are usually light gauge galvanised steel. Timber systems can be relatively traditional in that the construction mirrors what might be produced on site using components such as timber studs and sheathing. It can make use of timber Ibeams which give longer spans with a relatively lightweight beam. A third option is Structural Insulated Panel systems, which use fewer studs and rely in part on the bond between rigid insulation core and outer sheathing materials for strength.

One factor that differentiates all prefabricated timber systems from what might be termed traditional timber frame is the amount of work undertaken in the factory.

While there does not appear to be a formal definition separating the two, the prefabricated panel might include any insulation material, the sheathing boards and possibly some services.

Classification of prefabrication

Classification of prefabricated construction system

Smaller degree Prefabrication: Here the prefabrication is done in the smaller scale. precast brick

Medium degree Prefabrication: Here the prefabrication is done in the moderate scale. Large

degree Prefabrication : Here the prefabrication is done in the large scale.

Advantages

1. Moving partial assemblies from a factory often costs less than moving pre production resources to each site
2. Deploying resources on-site can add costs; prefabricating assemblies can save costs by reducing on-site work
3. Factory tools - jigs, cranes, conveyors, etc. - can make production faster and more precise
4. Factory tools - shake tables, hydraulic testers, etc. - can offer added quality assurance
5. Consistent indoor environments of factories eliminate most impacts of weather on production
6. Cranes and reusable factory supports can allow shapes and sequences without expensive on-site falsework

7. Higher-precision factory tools can aid more controlled movement of building heat and air, for lower energy consumption and healthier buildings
8. Factory production can facilitate more optimal materials usage, recycling, noise capture, dust capture, etc.
9. Machine-mediated parts movement, and freedom from wind and rain can improve construction safety

Disadvantages

1. Transportation costs may be higher for voluminous prefabricated sections than for their constituent materials, which can often be packed more densely.
2. Large prefabricated sections may require heavy-duty cranes and precision measurement and handling to place in position.

Design Principal of Prefabrication:

The Main reasons to choose Precast Construction method over conventional in method. 1. Economy in large scale project with high degree of repetition in work construction. 2. Special requirement in finishing.

3. Consistency in structural quality control.
4. Fast speed of construction.
5. Constraints in availability of site resources(e.g. materials & Laborites) 6. Other space & environmental constraints.
7. Overall assessment of some or all of the above factors which points to the superiority of adopting precast construction over convention method.

The following details gives. The cost implications of precast construction & conventional in situ method.

8. Large groups of buildings from the same type of prefabricated elements tend to v look drab and monotonous.

1. Local Jobs are last.

v The main reasons to choose. Precast Construction method over conventional in situ method.

1. Economy in large scale project with high degree of repetition in work execution.
2. Special architectural requirement in finishing.
3. Consistency in structural quality control.
4. Fast speed of construction.
5. Constraints in availability of site resources ce.g.materials & labour etc..
6. Other space & environmental constraints.
7. Overall assessment of some or all of the above factors which points to the superiority of adopting precast construction over conventional method

The following details gives the cost implications of precast construction & conventional in situ method.

Prefabrication Elements :

1. Flooring / Roofing system.
2. Priciest Beams
3. Precast Columns
4. Precast walk panels.
5. recast Stabs.

Classification :

The Prefabrication is classified as follow from the view of degree of Precast construction.

1. Small prefabrication
2. Medium Prefabrication
3. Large Prefabrication
4. Cast in Site Prefabrication

5. Off-Site (or) factory Prefabrication
6. Open system of prefabrication
7. Closed system of prefabrication
8. Partial prefabrication
9. Total prefabrication

Small Prefabrication :

The first 3 types are mainly classified according to their degree of precast

Elements using in that construction for eg.:brick is a small unit precast and used in building.

This is called as small prefabrication. That the degree of precast element is very positive **Medium Prefabrication :**

Suppose the roofing systems and horizontal members are provided with precast elements those construction are known as medium prefabricated construction here the degree of precast elements are moderate.

Large Prefabrication :

In large prefabrication most of the members like wall panels, roofing / flooring Systems, beams and columns are prefabricated. Here degree of precast elements are high.

Cast - in - site prefabrication : OFF - site (factory) prefabrication :

One of the main factor which affect the factory prefabrication is transport. The width of roads, mode of transport, vehicles are the factors which prefabrication is to be done on site or on factory.

Suppose the factory situated at a long distance from the construction site and the vehicle have to cross a congested traffic with heavy weighed elements the cost in site prefabrication is preferred even though the same condition are the cast in site prefabrication is preferred only when number of houses

and more for small elements the conveyance is easier with normal type of lorry and trailers. Therefore we can adopt factory (or) OFF site prefabrication for this type of construction.

Open system of prefabrication :

In the total prefabrication systems, the space framers are casted as a single unit and erected at the site. The wall fitting and other fixing are done on site. This type of construction is known as open system of prefabrication.

Closed system of prefabrication :

In this system the whole things are casted with fixings and erected on their position. **Partial prefabrication :**

In this method of construction the building element (mostly horizontal) required are precast and then erected. Since the costing of horizontal elements (roof / floor) often take there time due to erection of from work the completion of the building is delayed and hence this method is restored. In most of the building sites this method is popular more. Son in industrial buildings where the elements have longer spans. Use of double tees, channel units, cored stabs, slabs, hyperboloid shall etc., are some of the horizontal elements.

This method is efficient when the elements are readily available when the building reached the roof level. The delay caused due to erection of formwork, delay due to removal eliminated completely in this method of construction Suitable for any type of building provided lifting and erection equipments are available.

Total Prefabrication :

Very high speed can be achieved by using this method of construction. The method can be employed for frame type of construction or for panel type of or the total prefabrication can be on site or off-site. The choice of these two methods depend on the situations when the factory produced elements are transported and erected site we call if off-site prefabrication. If this method is to be adopted then we have a very good transportation of the products to site. If the elements are cast near the building site and erected, the transportation of elements can be eliminated, but we have consider the space availability for establish such facilities though it is temporary. The choice of the method of construction also depends on the following;

1. Type of equipment available for erection and transport.

2. Type of structural scheme (linear elements or panel)
3. Type of connections between elements.
4. Special equipment devised for special method construction

Modular coordination

Modular coordination is a concept for coordinating dimensions and space for which building components are positioned. Basic unit of MC is module 1M which is equal to 100mm. MC is internationally accepted by the International Standard of Organization (ISO). The introduction of MC in building facilitate proper planning, design construction and assembly of building components. The principle objective of implementation of MC is to improve productivity, more flexibility in design and construction activities.

Modular co-ordination Grid:

Structural Grid:

It is used to locate the structural components such as beam and columns.

Planning Grid:

It is used for locating the space for building components like rooms.

Controlling Grid:

It is used for locating internal walls. Modular coordinated grid is used for locating the building components and the grids can be available in both horizontal and vertical planes. The grids are generated by measurement in modules.

Dimensional Grid:

Modular coordinated grid network defines the space available for placing the components. An important factor is that the component must always be undersized to grid size for providing space for joint space. Manufactured length of unit nominal length 11 ½ inch grid size would be 12 inch because of units were designed to be placed with ½ inch joints.

In modular coordination system, in place of geometric series, a different system of preferred dimensions is used. For larger dimensions it is represented in modules like 1M=0.1m, for smaller dimensions sub modular increments 50mm or 25mm are used.

Modular coordination system provides,

1. Defining coordinating spaces for building elements and components.
2. Rules for maintaining the component size while manufacturing
3. Rules for selecting the component size and providing the required grid size in building.
4. The MC system allows standardization in design of building components, it encourages manufacturers and assemblers to enter in open market.
5. It is difficult to manufacture the component in SI unit mm tolerance. But it is easier for manufacturer to make in module tolerance system.

Advantages of Modular Coordination:

1. Facilitate cooperation between building designer, manufacturer, traders, contractors.
2. Improves freedom in design and permits flexibility.
3. Encourages the possibility of interchanging the components.
4. Simplifies positioning and placing of components
5. Ensures dimensional coordination between component with the rest of the building.
6. It is possible to get maximum economy in the production of components.
7. Reduces the need for making special sizes.
8. Increases the number of choices of components because of interchangeability.
9. Improves quality and productivity of construction.
10. Wastage in production and time taken for installation of components is reduced.
11. It helps to achieve the responsibility in constructing the building.

Q. Describe lifts and its types.

ANS:

An elevator or lift is a hoisting or lowering mechanism, designed to carry passengers or freight, and is equipped with a car and platform that typically moves in fixed guides and serves two or more landings.

Classified as:

1. electric traction type
2. hydraulic type

1. electric traction type

- Traction elevators have an elevator car and counterweight attached to opposite ends of hoist ropes.
- The hoist ropes pass over a driving machine that raises and lowers the car.
- Traction elevators run on load-bearing rails in the elevator hoist-way.
- Traction elevators are most often used in mid-rise and high-rise buildings with five or more floors.

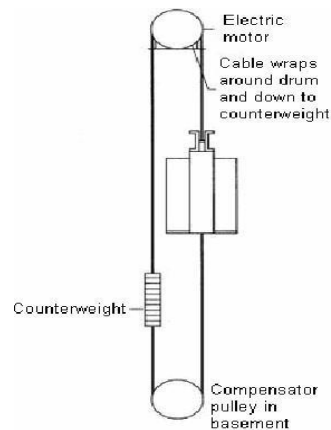

Traction Drum Arrangement

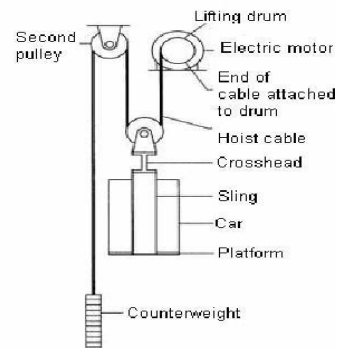

Lifting Drum Arrangement

2. hydraulic type

- Hydraulic elevators, on the other hand, are raised by forcing pressurized oil through a valve into a steel cylinder located above ground or underground.
- The pressure forces a piston to rise, lifting the elevator platform and car enclosure mounted on it.
- The car is lowered by opening the valve and allowing the weight of the car to force oil from the cylinder in a controlled manner. When the valve is closed the car is stopped.
- Hydraulic elevators are commonly found in low-rise buildings with two to five floors.

Other types are:

1. Bed Passenger Lift
2. Escalator

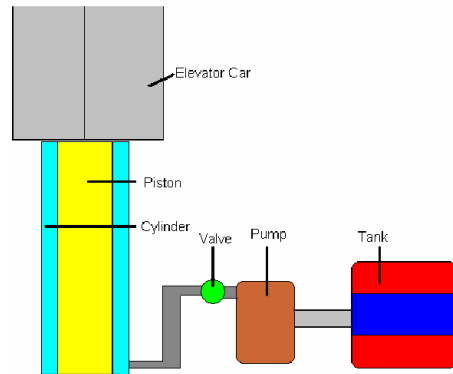

3. Freight Lift
4. Lift Bank
5. Passenger Conveyor
6. Passenger Lift
7. Service Lift
8. Vehicle Lift

1. **Bed Passenger Lift** means a lift used for transportation of passenger and bed including stretcher.

2. **Escalator** means an inclined, continuous stairway which is driven by mechanical power and used for raising or lowering passengers
3. **Freight Lift** means a lift mainly intended for the transport of goods, which are generally accompanied by persons handling the goods.
4. **Lift Bank** means a lift system with two or more lift cars serving a zone
5. **Passenger Conveyor** means a continuous walkway which is driven by mechanical power and used for the conveyance of passengers on the same or between different traffic levels.
6. **Passenger Lift** means a lift which is wholly or mainly used to carry persons.
7. **Service Lift** means a lift, used or intended to be used exclusively for carrying goods, having a rated load of not more than 250 kg and a car in which the area of the floor is not more than 1 m and whose height is not more than 1200 mm.
8. **Vehicle Lift** means a lift which is suitably dimensioned and designed for carrying motor vehicles

Q. Uses of lifts and escalator.

ANS:

Uses of elevators

1. Passenger Elevators are designed to move people between different floors of a building, their capacity being related to available floor space.
2. Passenger elevators may be specialized for the service they perform, including: Hospital emergency (Code blue), front and rear entrances, double Decker, and other uses.
3. Express elevators are designed to move people from ground floor to a sky lobby skipping several floors in between at a high speed.
4. Wheelchair, or platform lifts, a specialized type of elevator designed to move a wheelchair 6 ft (1.8 m) or less, often can accommodate just one person in a wheelchair at a time with a maximum load of 1000 lb (455 kg).
5. Freight Elevators are meant to carry heavy loads generally 2300 to 4500 kg. They usually don't comply with fire service requirements and carrying passengers is generally prohibited unless specified.
6. On aircraft carriers, elevators carry aircraft between the flight deck and the hangar deck for operations or repairs. These elevators are designed for much greater capacity than any other elevator.
7. A small freight elevator is often called a dumbwaiter, often used for the moving of small items such as dishes in a 2-story kitchen or books in a multi-story rack assembly. Passengers are never permitted on dumbwaiters.

8. A special type of elevator is the paternoster, a constantly moving chain of boxes, generally used in industrial plants.
9. Grain Elevators are used to elevate grain for storage in large vertical silos

For the safe use of lifts

- Maintain all the safety devices operative
- Don't overload lifts
- Don't interfere with lift doors and equipment
- Don't use the lift when there is a fire
- Don't jump inside lift
- Children must be accompanied by adults when using lifts
- Stay clear of lift doors, especially when the lift doors are opening or closing

For the safe use of escalators

- Hold handrail and to prevent accident, please don't walk on escalators
- Hold children's hand
- Don't lean over handrail
- Don't play or run on escalators
- Keep your feet away from the skirting or yellow stripes
- Keep Trolleys strollers and wheelchairs off escalators
- Don't play with emergency stop button which is to be used only when under emergency situation.

Q. Describe soil and waste water installations in high rise buildings

Ans:

Materials used for waste and discharge systems

<i>Material</i>	<i>Application</i>	<i>Joining</i>
Cast iron	50 mm and above vent and discharge stacks	Lead caulking with molten or fibrous lead; cold compound caulking
Galvanized steel	Waste pipes	BSPT screwed
Copper	Waste pipes and traps	Compression, capillary, silver solder, bronze weld or push-fit ring seal
Lead	Waste pipes and discharge stacks	Soldered or lead welded
ABS	Up to 50 mm waste and vent pipes	Solvent cement and push-fit ring seal
High-density polyethylene	Up to 50 mm waste and ventilating pipes and traps	Push-fit ring seal and compression fittings
Polypropylene	Up to 50 mm waste and ventilating pipes and traps	Push-fit ring seal and compression couplings
Modified PVC	Up to 50 mm waste and vent pipes	Solvent cement and push-fit ring seal
Unplasticized PVC	Over 50 mm soil and vent stacks; vent pipes under 50 mm	Solvent cement and push-fit ring seal
Pitch fibre	Over 50 mm discharge and vent stacks	Driven taper or polypropylene fitting with a push-fit ring seal

▫ Maintenance

Periodic inspection, testing, trap clearance, removal of rust and repainting should be a feature of an overall service maintenance schedule. Washers on access covers require occasional replacement. The use of chemical descaling

agents, hand or machine operated rodding and high-pressure blockage removal must be carefully related to the drainage materials and the skill of the operator.

▪ **Lime scale removal**

Lime scale is found in hard-water areas. A dilute corrosion-inhibited acid-based descaling fluid is applied directly to scale visible on sanitary appliances and is then thoroughly flushed with clean water. The fluid is a mixture of 15% inhibited hydrochloric acid and 20% orthophosphoric acid.

▪ **Removal of grease and soap residues**

A strong solution of 1 kg of soda crystals and 9 l of hot water is flushed through the system. The soda crystals are mixed with the hot water in a basin. When the soda is fully dissolved, the plug is released. This may be necessary frequently in commercially used appliances.

▪ **Blockage**

A hand plunger may be sufficient but repeated blockage should be investigated. Hand rodding from the nearest access point can be performed using various tools as appropriate. A kinetic ram gun can be used for blockage in branch pipes. The impact of compressed air from the gun creates a shock wave in the water, which dislodges the solids. However, a blow-back from a stubborn blockage may injure the operator and damage the pipework and therefore the ram gun must be limited to the removal of soft materials.

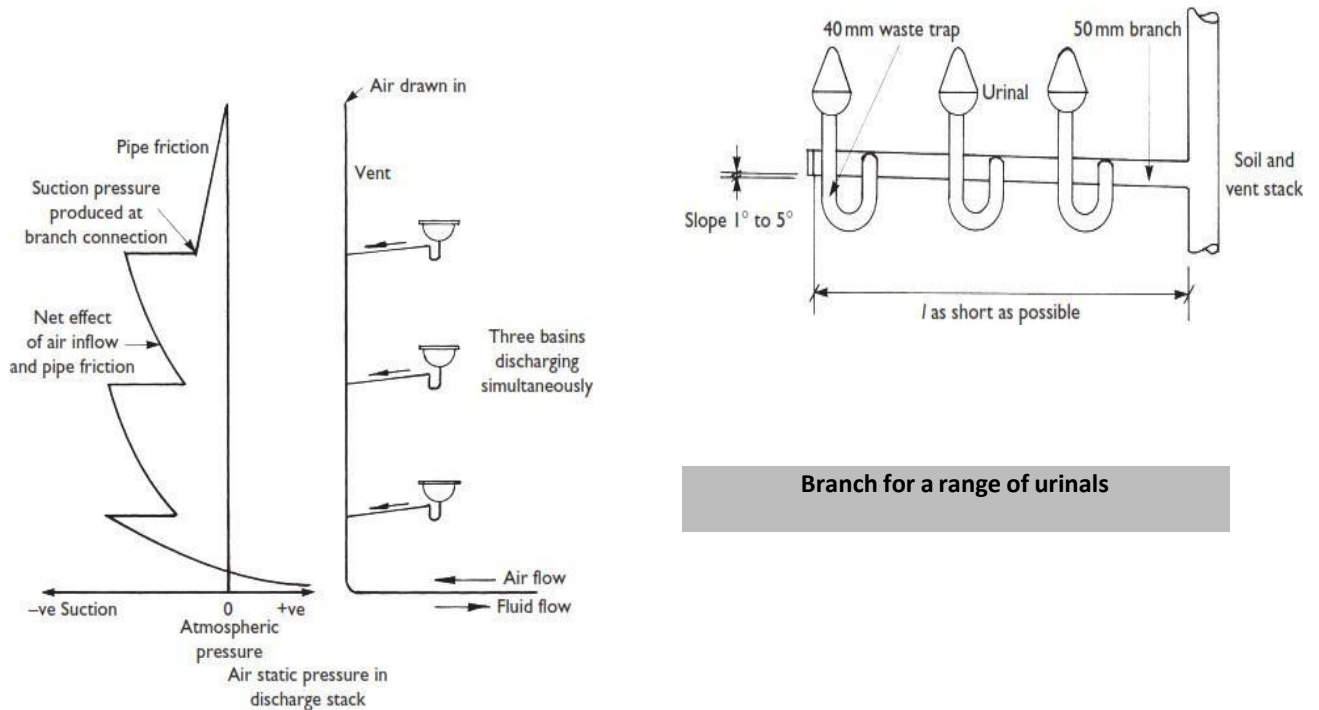

Branch for a range of urinals

Soil and vent stack in housing.

Air static pressure distribution in soil and vent pipes.

Q. Electrical distribution within a building:

- d) Electrical services –
 - i) requirements in high rise buildings
 - ii) Layout of wiring - types of wiring
 - iii) Fuses and their types
 - iv) Earthing and their uses

The safe and economical use of electricity is of paramount importance to the building user and the world as it is the most highly refined form of energy available. Electricity production consumes up to three times its own energy value in fossil fuel, and electricity in its distributed form is potentially lethal.

In this chapter the handling methods and safety precautions for utilizing electricity are explained and a range of calculations, which can easily be performed by the services designer or constructor prior to employing specialist help, is introduced.

Electrical distribution within a building:

The incoming cable, residual current device and meter are the property of the electricity supply authority. Underground cables are at a depth of 760 mm under roads, and enter the building through a large radius service duct of 100 mm internal diameter. A drainpipe can be used for this purpose, laid through the foundations and rising directly to the meter compartment. External meter compartments can be used. The meter should not be exposed to damp or hot conditions and the electricity supply authority's advice should be sought. Figure 13.6 shows a distribution system for a dwelling.

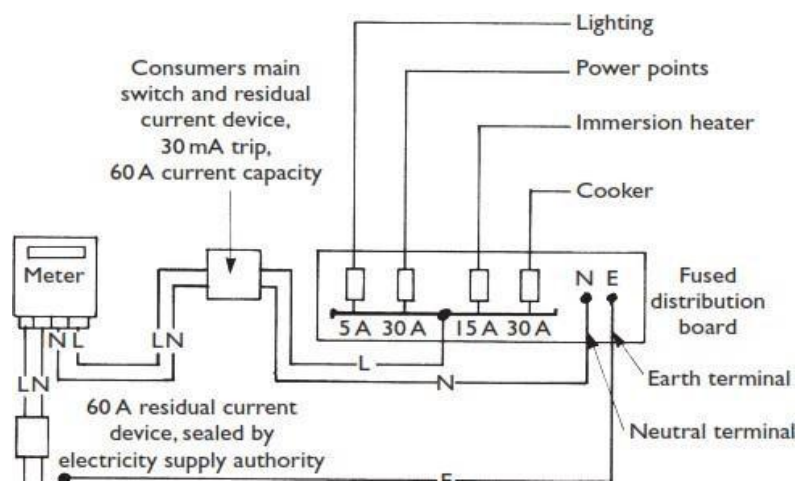

EARTHING SYSTEMS

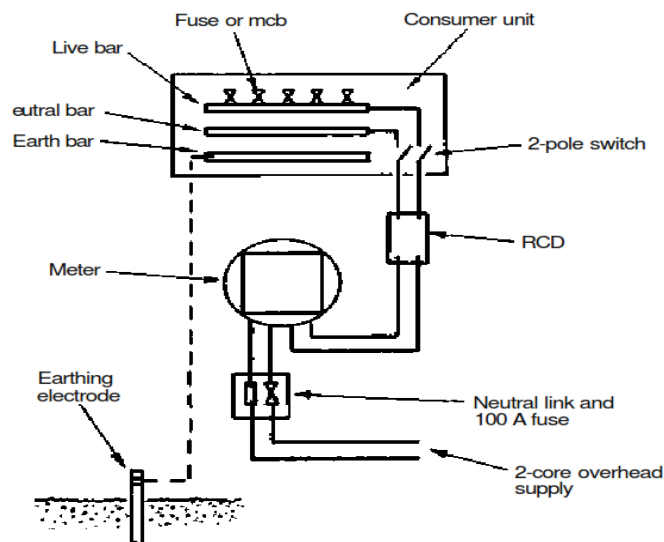

Cold Water Distribution in high rise building lay out of installation

- ▶ **Direct Cold Water Systems** ~ the cold water is supplied to the outlets at mains pressure the only storage requirements is a small capacity cistern to feed the hot water storage tank. These systems are suitable for districts which have high level reservoirs with a good supply and pressure. The main advantage is that drinking water is available from all cold water outlets
- ▶ For efficient operation, a high pressure water supply is essential particularly at periods of peak demand. Pipe work is minimal and the storage cistern supplying the hot water cylinder need only have 115 litres capacity. The cistern may be located within the airing cupboard or be combined with the hot water cylinder. Drinking water is available at every draw-off point and maintenance

valves should be fitted to isolate each section of pipe work. With every outlet supplied from the main, the possibility of back siphonage must be considered. Back siphonage can occur when there is a high demand on the main. Negative pressure can then draw water back into the main from a submerged inlet, e.g. a rubber tube attached to a tap or a shower fitting without a check valve facility left lying in dirty bath water.

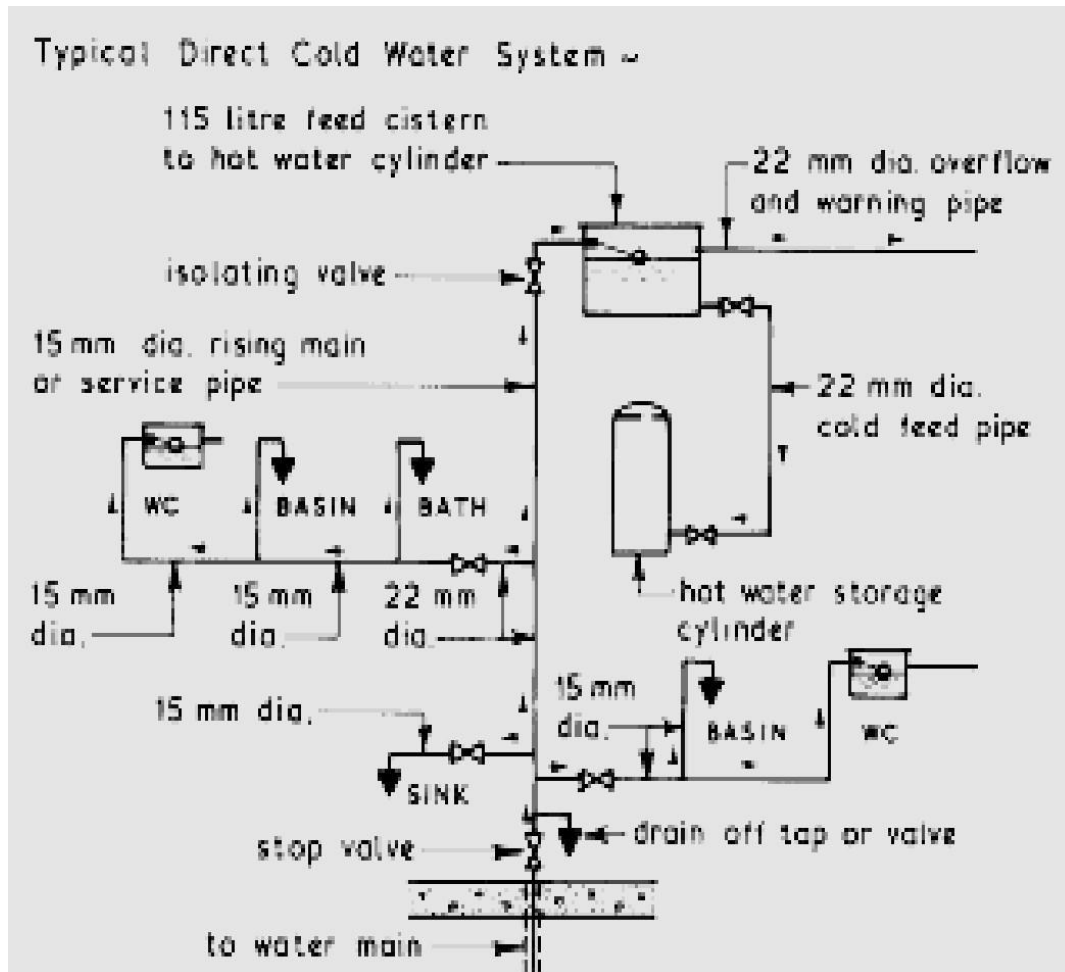

HOT WATER SUPPLY SYSTEMS

- **Direct System of Hot Water Supply**

The hot water from the boiler mixes directly with the water in the cylinder. If used in a soft' water area the boiler must be rust proofed. This system is not suited to hard' waters, typical of those extracted from boreholes into chalk or limestone strata. When heated the calcium precipitates to line the boiler and primary pipe work, eventually 'furring up' the system to render it ineffective and dangerous. The storage cylinder and associated pipe work should be well insulated to reduce energy losses. If a towel rail is fitted, this may be supplied from the primary flow and return pipes.

- **Indirect System of Hot Water Supply**

This system is used in 'hard' water areas to prevent scaling or 'furring' of the boiler and primary pipe work. Unlike the direct system, water in the boiler and primary circuit is not drawn off through the taps. The same water circulates continuously

throughout the boiler, primary circuit and heat exchange coil inside the storage cylinder. Fresh water cannot gain access to the higher temperature areas where precipitation of calcium would occur. The system is also used in combination with central heating, with flow and return pipes to radiators connected to the boiler. Boiler water temperature may be set by thermostat at about 80°C.

A safety valve is not normally required on indirect open vent systems, as in the unlikely occurrence of the primary flow and vent becoming obstructed, water expansion would be accommodated up the cold feed pipe.

Indirect Hot Water System for a High Rise Building

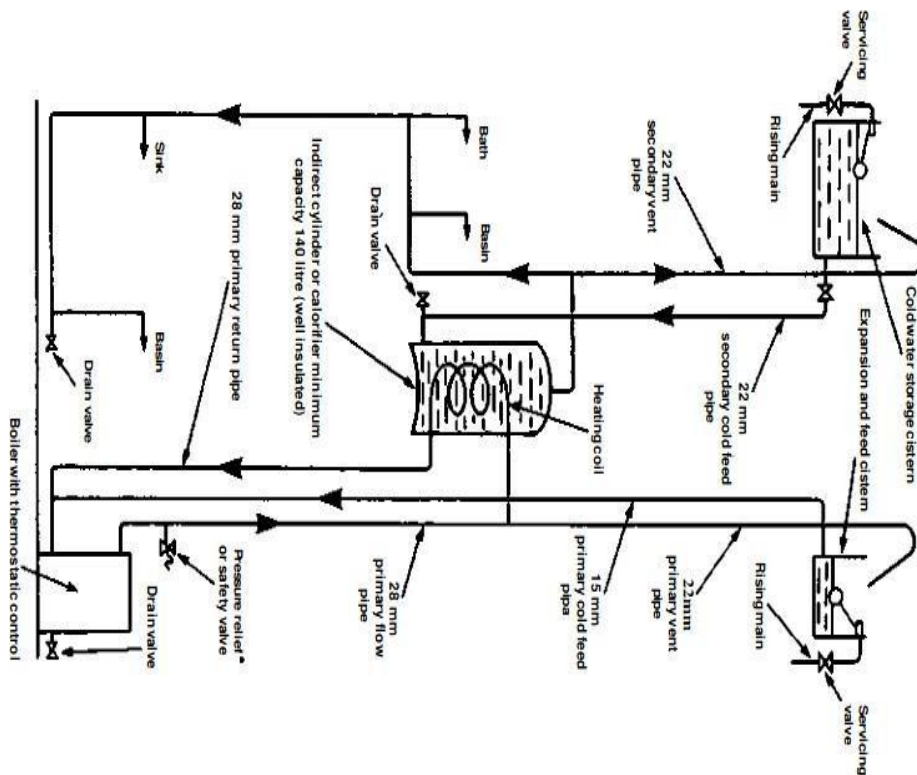

VENTILATION

Ventilation - a means of changing the air in an enclosed space:

Ventilation is **required to**

- | Provide fresh air for respiration - approx. 0.1 to 0.2 l/s per person
- | Preserve the correct level of oxygen in the air
- | Control carbon dioxide content to no more than 0.1% concentrations above 2% are unacceptable as carbon dioxide is poisonous to humans and can be fatal.
- | Control moisture - relative humidity of 30% to 70% is acceptable.
- | Remove excess heat from machinery, people, lighting, etc.
- | Dispose of odours, smoke, dust and other atmospheric contaminants.
- | Relieve stagnation and provide a sense of freshness.

Ventilation rates

Room/building/accommodation	Air changes per hour
Assembly/entrance halls	3-6
Bathrooms (public)	6*
Boiler plant rooms	10-30†
Canteens	8-12
Cinema/theatre	6-10
Classrooms	3-4
Dance halls	10-12
Dining hall/restaurants	10-15
Domestic habitable rooms	approx. 1*
Factories/garages/industrial units	6-10

Types of Ventilation

1. Natural ventilation
2. Artificial/ Mechanical ventilation

1. Natural ventilation

Ventilation provided by various natural means is called natural ventilation. Natural ventilation is an economic means of providing air changes in a building.

The sources for natural ventilation are

- wind effect/pressure and
- Stack effect/pressure.
- Passive Stack Ventilation (PSV)

• Stack effect:

Stack Effect is an application of convected air currents. Cool air is encouraged to enter a building at low level. Here it is warmed by the occupancy, lighting, machinery and/or purposely located heat emitters. A column of warm air rises within the building to discharge through vents at high level.

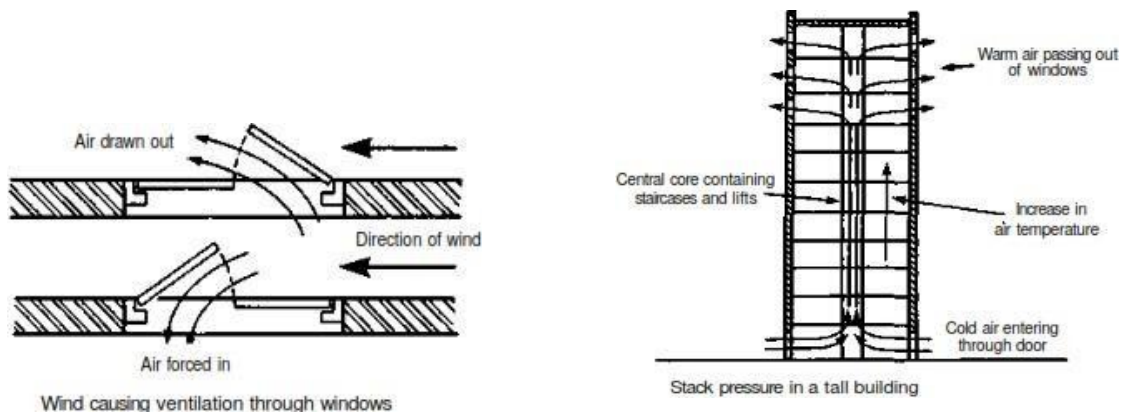

- Passive Stack Ventilation (PSV)

- PSV consists of vertical or near vertical ducts of 100 to 150 mm diameter, extending from grilles set at ceiling level to terminals above the ridge of a roof. Systems can be applied to kitchens, bathrooms, utility rooms and sometimes sanitary accommodation.
- PSV is energy efficient and environmentally friendly with no running costs. It works by combining stack effect with air movement and wind passing over the roof. It is self-regulating, responding to a temperature differential when internal and external temperatures vary.

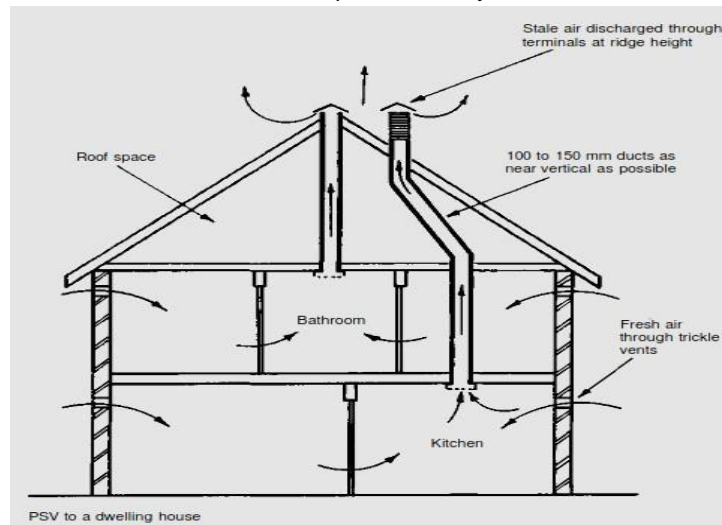

2. Mechanical ventilation

Mechanical ventilation systems are frequently applied to commercial buildings, workshops, factories, etc., where the air change requirements are defined for health and welfare provision.

- Mechanically Assisted Ventilation Systems (MAVS)
- Mechanical Ventilation with Heat Recovery (MVHR)
- Fan assisted ventilation systems

● Mechanically Assisted Ventilation Systems (MAVS)

- MAVS may be applied to dwellings and commercial premises where PSV is considered inadequate or impractical.
- This may be because the number of individual ducts would be excessive, i.e. too space consuming and obtrusive with several roof terminals.

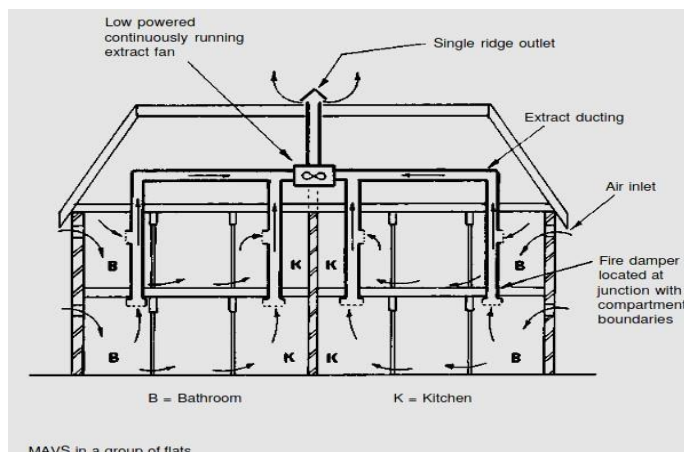

- A low powered (40 W) silent running fan is normally located within the roof structure. It runs continuously and may be boosted by manual control when the level of cooking or bathing activity increases.
- Humidity sensors can also be used to automatically increase air flow.

▶ Mechanical Ventilation with Heat Recovery (MVHR)

- MVHR is a development of MAVS to include energy recovery from the warmth in fan extracted moist air from bathrooms and kitchens.
- The heat recovery unit contains an extract fan for the stale air and a fresh air supply fan and a heat exchanger. This provides a balanced continuous ventilation system, obviating the need for ventilation openings such as trickle ventilators.

- Apart from natural leakage through the building and air movement from people opening and closing external doors, the building is sealed to maximize energy efficiency. Up to 70% of the heat energy in stale air can be recovered

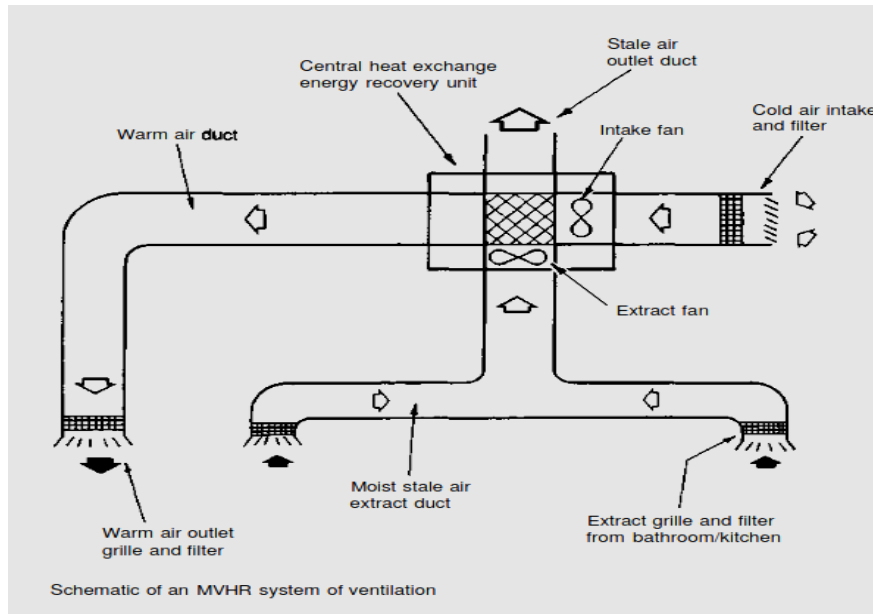

► **Fan assisted ventilation systems**

- Fan assisted ventilation systems supplying external air to habitable rooms must have a facility to pre-heat the air.
- They must also have control over the amount of air extracted; otherwise there will be excessive heat loss.

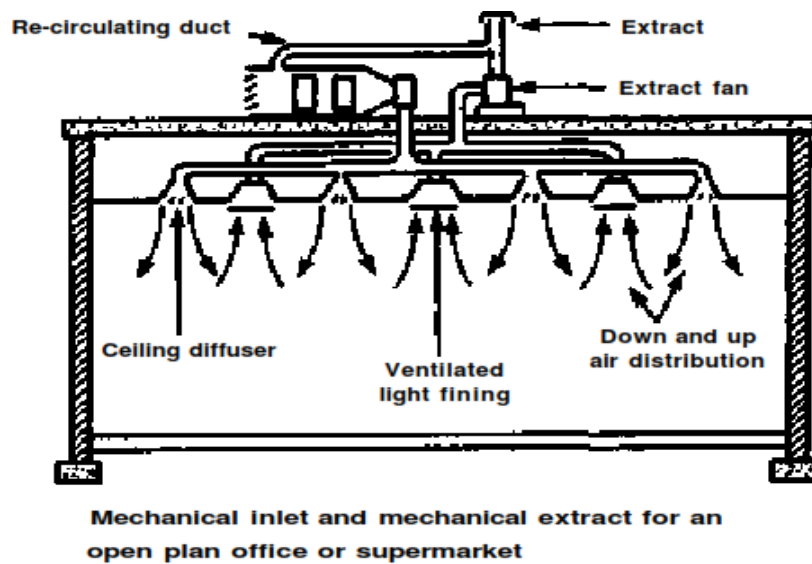

Types of Fan

- **Propeller fan** - does not create much air pressure and has limited effect in ductwork. Ideal for use at air openings in windows and walls.

- **Axial flow fan** - can develop high pressure and is used for moving air through long sections of ductwork. The fan is integral with the run of ducting and does not require a base.
- **Bifurcated axial flow fan** - used for moving hot gases, e.g. flue gases, and greasy air from commercial cooker hoods.
- **Cross-flow or tangential fan** - used in fan convector units.
- **Centrifugal fan** - can produce high pressure and has the capacity for large volumes of air. Most suited to larger installations such as air conditioning systems. It may have one or two inlets. Various forms of impeller can be selected depending on the air condition. Variable impellers and pulley ratios from the detached drive motor make this the most versatile of fans.

Lighting – Requirement of lighting, Measurement of light intensity

Lighting or illumination is the deliberate application of light to achieve some practical or visual effect.

Lighting includes the use of both artificial light sources such as lamps and light fixtures, as well as natural illumination by capturing daylight.

Indoor lighting is usually accomplished using light fixtures.

Lighting has the following requirements:

- For visibility
- For comfort
- For daily habitable purposes
- For a refreshing environment
- For growth of life and intelligence

Types of lighting/ illumination:

1. Natural illumination
2. artificial illumination

1. Natural illumination

Natural illumination is primarily due to SUN during daytime. So Day lighting is often used as the main source of light during daytime in buildings.

- Natural illumination by penetration of direct solar and diffuse sky visible radiation requires correctly designed passive architecture.
- Large glazed areas may provide sufficient day lighting at some distance into the building, Using windows, skylights, or light shelves.
- Reflected illumination from other buildings, particularly from those having reflective glazing or metallic architectural features, may cause annoyance.
- Higher day lighting can also cause glare, overheating and high heating and cooling energy costs.

2. artificial illumination

Artificial lighting is provided to supplement daylight on a temporary or permanent basis. Artificial lighting is the illumination by the help of light bulbs, lamps and several other electrical lighting systems.

- Artificial light sources such as lamps and light fixtures are necessary during dark areas of buildings both in day and night time.
- Local control of lights by manual and/or automatic switches aids economy in electricity consumption.

Measurement of light intensity

Illumination intensity/ illuminance:

- ❖ It is a measure of the intensity of the incident light
- ❖ illuminance, measured in **lux** i.e. **lumen/m²** (**1 lux = 1 lumen / sq meter**) a measure of the intensity, as perceived by the human eye, of light that hits or passes through a surface.
- ❖ Light Level or illuminance, is **the total luminous flux incident on a surface, per unit area**. The work plane is where the most important tasks in the room or space are performed.
 - The outdoor light level is approximately 10,000 lux on a clear day.
 - In the building, in the area closest to windows, the light level may be reduced to approximately 1,000 lux.
 - In the middle area its may be as low as 25 - 50 lux. Additional lighting equipment is often necessary to compensate the low levels.
 - Earlier it was common with light levels in the range 100 - 300 lux for normal activities.
 - For precision and detailed works, the light level may even approach 1500 - 2000 lux.

The table below is guidance for recommended light level in different work spaces

Activity	Illumination (lux, lumen/m ²)
Family living room	50 lux
Hallway/toilet in office buildings	80 lux
Homes, Theaters, Archives	150
Easy Office Work, Classes	250-300
Show Rooms, Laboratories	500
Detailed Drawing Work, Very Detailed Mechanical Works	1500-2000

QUESTIONS AND ANSWERS

1. write four properties of fresh concrete

- a. Setting
- b. Workability
- c. Bleeding and Segregation
- d. Hydration

2. write four properties of hardened concrete

- a. Strength
- b. Durability
- c. Creep
- d. Shrinkage
- e. Elasticity
- f. Permeability

3. What is an escalator?

Escalator is a moving staircase – a conveyor transport device for carrying people between floors of a building

4. Define plinth band

Plinth Band

Plinth band is a band provided at plinth level of walls on top of the foundation wall. This is to be provided where strip footings of masonry are used and the soil is either soft or uneven in its properties as frequently happens in hill tracts.

5. What is a dragline?

It is an excavating equipment, used to excavate earth and loading earth into hauling units, also deposit the excavated earth in embankments or spoil banks.

6. Define Owning and operating cost

The cost of ownership of equipment to which the fuel cost is added for running the equipment

7. What is curing of concrete?

Curing is the process of controlling the rate and extent of moisture loss from concrete during cement hydration

8. Write ratios for M15, M20.

M15 - 1:2:4, M20 – 1: 1½:3

9. Write two methods of curing.

- a. Ponding
- b. Wet covering

10. Write and define the unit of illumination.

lux i.e. lumen/m² is unit to measure illumination and is defined as is the total luminous flux incident on a surface, per unit area

11. Define workability of concrete.

Workability is the ability of a fresh concrete mix with which the concrete can mix, transport, place and compacted is called the workability of concrete

12. Define creep of concrete.

Creep is the tendency of concrete structures to move slowly or deform permanently under the influence of stresses.

13. What are the Factors affecting workability

- a. Water content in the concrete mix
- b. Amount of cement & its Properties
- c. Aggregate Grading (Size Distribution)
- d. Nature of Aggregate Particles (Shape, Surface Texture, Porosity etc.)

14. How To improve the workability of concrete

- a. increase water/cement ratio
- b. increase size of aggregate
- c. increase the mixing time
- d. with addition of air-entraining mixture

15. Write four Methods of proportioning concrete mix.

- a. ACI Mix design method
- b. DOE Mix design method
- c. RLL Mix design method
- d. Minimum void method

16. What are plan configuration problems

- a. symmetry
- b. Regularity
- c. Separation of Blocks
- d. simplicity

17. What is Retrofitting of Structures?

Retrofitting is the modification of existing structures to make them more resistant to seismic activity, ground motion, or soil failure due to earthquakes.

18. What are the compacting equipments?

- a. tamping rollers
- b. Smooth wheel rollers,
- c. Pneumatic tired rollers and
- d. vibrating compactors

19. What are the earth moving equipments

- a. drag line,
- b. tractor,
- c. bulldozer,
- d. Power shovel

20. What is batching of concrete?

Ans: Batching is the process of weighing or volumetrically measuring each ingredients (cement , sand , coarse aggregate, water and admixture) and placing the ingredients into a mixer for a batch of concrete to produce a uniform quality concrete mix.

21. Write the types of drum type mixers.

Ans: 1. Tilting 2. Non-Tilting 3. Reversing or Forced Action

22. What is hydration of cement?

Ans: The reaction of cement with water is termed "hydration". This involves many different reactions, often occurring at the same time. As the reactions proceed, the products of the hydration process gradually bond together the individual sand and gravel particles, and other components, to form a solid mass.

23. Write two methods of measuring workability of concrete.

Ans: Slump cone test, Compacting factor test

24. Define segregation and bleeding of concrete.

Segregation can be defined as the separation of the constituent materials of concrete

Bleeding in concrete is sometimes referred as water gain. It is a particular form of segregation, in which some of the water from the concrete comes out to the surface of the concrete

25. define W/C ratio of concrete

The **water–cement ratio** is the ratio of the weight of water to the weight of cement used in a concrete mix and has an important influence on the quality of concrete produced. A lower water-cement ratio leads to higher strength and durability

26. What are the types of elevator?

- a. electric traction type
- b. hydraulic type

27. What is Stack effect?

- Stack effect is the phenomenon in a building or building component caused by wind pressure and temperature differentials which results in air being drawn through some components of a building and out others creating a continuous pattern of air flow.
- During the heating season, the warmer indoor air rises up through the building and escapes at the top either through open windows, ventilation openings, or other forms of leakage. The rising warm air reduces the pressure in the base of the building, drawing cold air in through either open doors, windows, or other openings and leakage. During the cooling season, the stack effect is reversed

28. What are Ceiling Band and Gable Band?

Ceiling Band

It is a band provided immediately below the roof or floors.

Gable Band

It is a band provided at the top of gable masonry below the purlins.

29. What is earthquake?

An earthquake is the vibration of the earth's surface that follows a sudden release of energy in the crust. During an earthquake, the ground surface moves in all directions

30. Why Ventilation is required?

- a. Provide fresh air for respiration
- b. Preserve the correct level of oxygen in the air
- c. Control carbon dioxide content to no more than 0.1%
- d. Control moisture

31. What are the types of hot water supply systems

- a. **Direct System of Hot Water Supply**
- b. **indirect System of Hot Water Supply**

32. What is curing requirements of Concrete

Curing is necessary to provide continuously wetting the exposed surface thereby preventing the loss of moisture from it. Ponding or spraying the surface with water are methods typically employed to this end.

33. What is design mix concrete?

It is a process of selecting suitable ingredients and determining their relative proportions with the objective of producing concrete of having certain minimum workability, strength and durability as economically as possible.

34. What are the data required for mix design?

- a. Characteristic compressive strength
- b. Degree of workability
- c. Type and maximum size of aggregate to be used and
- d. Standard deviation (s) of compressive strength of concrete.

35. define bulldozer

It is an excavating equipment for short haul applications upto 100m, and is a versatile equipment.

36. What are the factors affecting owning and operating cost of equipment?

- a. initial cost
- b. service condition
- c. no. of hours it is to be used per year
- d. Useful life etc.

37. What are the costs included in owning and operating?

- a. depreciation cost
- b. maintenance and repair cost
- c. investment cost
- d. fuel cost
- e. lubricating oil cost

38. What are the advantages of mix design?

- a. Better strength
- b. Better imperviousness and durability
- c. Dense and homogeneous concrete
- d. Economical

39. What are the Requirements of Lighting?

- a. For visibility
- b. For comfort
- c. For daily habitable purposes
- d. For a refreshing environment
- e. For growth of life and intelligence

40. What are the systems of Mechanical ventilation?

- a. Mechanically Assisted Ventilation Systems (MAVS)
- b. Mechanical Ventilation with Heat Recovery (MVHR)
- c. Fan assisted ventilation systems

PREFABRICATION

- Prefabrication is the practice of assembling components of a structure in a factory or other manufacturing site, and transporting complete assemblies or subassemblies to the construction site where the structure is to be located.
- Prefabrication is one of the architectural constructions. Large units of a building are produced in factories to be assembled, ready-made, on the building site.
- This technique permits the speedy erection of very large structures. Units may include doors, stairs, windows, wall panels, floor panels, roof trusses and even entire buildings. Prefabricated building:
- Prefabricated building is a type of building that consists of several factory-built components or units that are assembled on-site to complete the unit. The term 'prefabricated' is buildings built in components (e.g. panels), modules (modular homes), transportable sections (manufactured homes), It may also be used to refer to mobile homes.
- Different Between Prefabricated Constructions and Conventional Type: The conventional method of building a house is to transport bricks, timber, cement, sand, and construction aggregate, etc to the site, and to construct the house on site from these materials.
- In prefabricated construction, only the foundations and floor slabs are constructed in this way, while sections of walls and roof are prefabricated

Need for Prefabrication:

1. Cost of construction
2. shorter construction time ☞ easy of expansion
3. utilization of material
4. attractive finishes
5. highly efficient for weather resistance
6. single source assurance
7. insurance advantage
8. Material Properties In of Prefabricated Structures Quick to assemble ☞ Cost-effective
9. Portable/movable
10. Strong
11. Waterproof, Moisture proof
12. Fire Resistant

Prefabrication Types:

1. Conventional prefabrication construction is the most traditional construction method where all the construction activities are in-situ practices on site:
2. Semi-prefabrication divides as two sub-categories: system formwork and nonstructural semi-prefabrication, involving a part of in-situ construction activities and a part of prefabrication. Normally, the non-structural semi-prefabrication is applied on façade, curtain walls, lost form systems and dry wall systems;
3. Comprehensive prefabrication involves a structural part and pre-finished construction. Examples of applications of structural comprehensive prefabrication include staircases, slabs, columns and beams: and
4. Volumetric off-site fabrication encloses usable space but does not constitute the whole building. Volumetric off-site fabrication is mainly used for 'facilities' and includes solutions on office washrooms, plant rooms, building services risers and lifts.

ADVANTAGES OF PREFABRICATION

1. Self-supporting ready-made components are used, so the need for formwork, shuttering and scaffolding is greatly reduced.
2. Construction time is reduced and buildings are completed sooner, allowing an earlier return of the capital invested.
3. Quality control can be easier in a factory assembly line setting than a construction site setting.
4. Prefabrication can be located where skilled labour is more readily available and costs of labour, power, materials, space and overheads are lower.
5. Time spent in bad weather or hazardous environments at the construction site is minimized.
6. Less waste may be generated and in a factory setting it may be easier to recycle it back into the manufacturing process, for instance it is less costly to recycle scrap metal generated in a metal fabrication shop than on the construction site.
7. On-site construction and congestion is minimized.

DISADVANTAGES OF PREFABRICATION

1. Careful handling of prefabricated components such as concrete panels or steel and glass panels is required.
2. Attention has to be paid to the strength and corrosion-resistance of the joining of prefabricated sections to avoid failure of the joint.
3. Similarly, leaks can form at joints in prefabricated components.
4. Transportation costs may be higher for voluminous prefabricated sections than for the materials of which they are made, which can often be packed more compactly.

5. Large prefabricated sections require heavy-duty cranes and precision measurement and handling to place in position.

Modular coordination:

Modular coordination or MC is a dimensional system. It is a dimension and space coordination concept in which building and components are placed at their designations based on the unit or basic module known as "1M" that equals to 100 mm. The use of MC is an important factor in IBS effective application as it completes the industry through quality control and increase of productivity.

QUESTIONS AND ANSWERS

1. Define prefabrication.

The term prefab can apply to any construction method where the significant part of the construction takes place off site in a factory . That produces relatively large complex features that assembled at the site into the finished building .

2. What is meant by modular Coordination?

Modular coordination is a concept for coordinating dimension and space for which building and component are dimensionally it used and positioned in basic units (or) modules. The standard specify that the module basic $M = 100 \text{ mm}$. As the basic unit be used in a square of M .

3. What are the characteristics of Modular concept .

- I) The basic module is small in terms of add size in order to provide design flexibility, yet large enough to promote simplification in the component variation in sizes .
- II) Industry friendly features that not only for manufacturing but also the transportation and assembly requirements .
- III) Internationally accepted to support international market .

4. Write out the advantages & disadvantages of prefabrication ?

- I) Self supporting readymade components are used ,so the need for formwork , shuttering and scaffolding is greatly reduced .
- II) On-site construction and condition is minimized .
- III) Less waste may occur.

Disadvantages :

- I) Careful handling of prefabricated components such as concrete panels (or) steel and glass Panels is reduced .
 - II) Similarly leaks can form at joints is prefabricated component .
- 5) Define the term Off-site fabrication .

Off-site fabrication is the process that incorporates prefabrication and preassemble the process involves the design and manufacture of units usually remote from the work site and the installation at the site to form the permanent work at the site.

- 6) Write short note on Production process .

The production of concrete blocks consists of four basic process They are,

- 1) Mixing 2) Moulding 3) Curing 4) Cubing

7) List out the limitations of prefabrication .

I) Extra reinforcement is required to take care of handling and erection stresses .

II) Temporary props may be required in some cases ,before the on-site concrete joints achieve strength .

III) The cracks may develop at the joints between the precast in –site concrete due to shrinkage and temperature stresses . To overcome them extra steel is required across joint.

8) What are all the Prefab materials ?

- Structural insulated panels (SIPs).
- Insulating concrete forms (ICFS).
- Prefab foundation system .
- Steel framing .
- Concrete framing .
- Large - modular system

9) Insulating concrete forms :

Insulating concrete forms (ICE) are a prefab construction material consisting of hollow EPS foam blocks that are stacked and glued together on-site , creating the form that is filled with reinforcing bars and concrete.

10) Write short note on Principles of MC Concept ?

The principle objective of implanting MC is to improve productivity through the reduction of wastages in the production ,installation process , to improve quality in the construction industry and to encourage an open system .

PART B

1.Explain Modular Coordination in detail

Modular coordination means the interdependent arrangement of a dimension based on a primary value accepted as a module. The strict observance of rules of modular coordination facilitated,

1. Assembly of single components into large components.
2. Fewest possible different types of component.
3. Minimum wastage of cutting needed.

Modular coordination is the basis for a standardization of a mass production of Component. A set of rules would be adequate for meeting the requirements of conventional and prefabricated construction. These rules are adaptable for,

a. The planning grid in both directions of the horizontal plan shall be

1. 3M for residential and institutional buildings,
2. For industrial buildings,
15M for spans up to 12m
30M for spans between 12m and 18m
60M for spans over 18m

The centre lines of load bearing walls shall coincide with the grid lines

b. In case of external walls the grid lines shall coincide with the centre line of the wall or a line on the wall 5 cm from the internal face of the wall

c. The planning module in the vertical direction shall be 1M up to and including a ht of 2.8M.

d. Preferred increments for the still heights, doors, windows and other fenestration shall be 1M.

e. In case of internal columns the grid lines shall coincide with the centre lines of columns. In case of external columns, the grid lines shall coincide with the centre lines of the columns in the storey or a line in the column from the internal face of the column in the topmost storey.

CONSTRUCTION EQUIPMENTS



Tractor, Excavator, Bulldozer

FACTORS AFFECTING SELECTION OF CONSTRUCTION EQUIPMENT

- ❖ **USE OF EQUIPMENT AVAILABLE WITH THE ORGANIZATION**
- ❖ **SUITABILITY FOR JOB CONDITION WITH SPECIAL REFERENCE TO CLIMATIC AND OPERATING CONDITIONS**
- ❖ **UNIFORMITY OF TYPE**
- ❖ **SIZE OF EQUIPMENT**
- ❖ **USE OF STANDARD EQUIPMENT**
- ❖ **COUNTRY OF ORIGIN**
- ❖ **UNIT COST OF PRODUCTION**
- ❖ **AVAILABILITY OF SPARE PARTS AND SELECTION OF MANUFACTURERS**
- ❖ **SUITABILITY OF LOCAL LABOUR FOR OPERATION**

TYPES OF EARTH EXCAVATION EQUIPMENTS

- 1. POWER SHOVEL**
- 2. BACK HOE**
- 3. DRAG LINE**
- 4. CLAM SHELL**

POWER SHOVEL

- LONG-LASTING.
- EXCAVATE ALL TYPES OF EARTH EXCEPT HARD ROCK

TYPES:

- WHEEL MOUNTED (HIGH SPEED - FIRM GROUND)
- CRAWLER MOUNTED (LOW SPEED - UNSTABLE SOIL)

BASIC PARTS:

- | | |
|---------------------|---|
| * TRACK SYSTEM | * CABIN |
| * CABLES | * RACK & STICK |
| * BOOM FOOT PIN | * SADDLE BLOCK |
| * BOOM POINT SHEAVE | * BUCKET (Size = .375 m ³ to 5 m ³) |

POWER SHOVEL

OPERATION:

CABLE CONTROLLED & IT MAKES *OUTWARD STROKES* WHILE DIGGING.

APPLICATIONS:

- CLOSE RANGE OF WORK.
- VERY HARD MATERIALS, BIG SIZED BOULDERS.
- DIGGING IN GRAVEL BANKS, CLAY PITS, CUTS IN ROAD WORKS, ROAD SIDE BERMS Etc.,

FACTORS CONTROLLING OUTPUT:

- | | |
|-------------------------|---------------------|
| * CLASS OF MATERIAL | * DEPTH OF CUTTING |
| * ANGLE OF SWING | * SKILL OF OPERATOR |
| * SIZE OF HAULING UNITS | * JOB CONDITION |

POWER SHOVEL

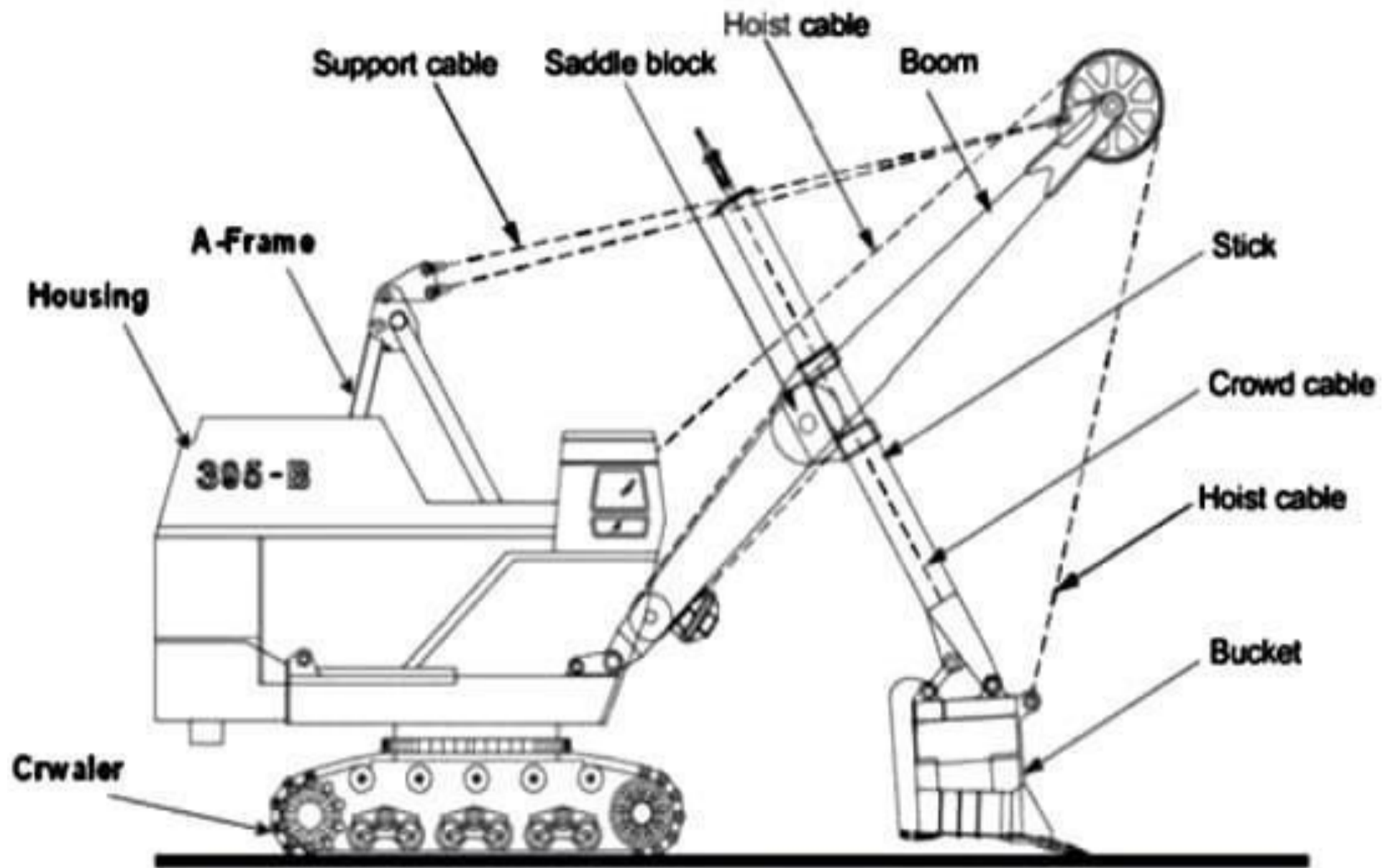

DRAG LINE

- The drag line is so name because of its prominent operation of dragging the bucket against the material to be dug.
- Unlike the shovel, it has a long light crane boom and the bucket is loosely attached to the boom through cables.
- Because of this construction, a dragline can dig and dump over larger distances than a shovel can do.
- Drag lines are useful for digging below its track level and handling softer materials.

DRAG LINE

BASIC PARTS:

- | | |
|--------------|---------------|
| * BOOM | * HOIST CABLE |
| * DRAG CABLE | * HOIST CHAIN |
| * DRAG CHAIN | * BUCKET |

APPLICATIONS:

- Dragging softer material and below its track level
- It is very useful for excavating trenches when the sides are permitted to establish their angle of repose without shoring.
- It has long reaches.
- Excavation for canals and depositing on the embankment without hauling units.

DRAG LINE

FACTORS CONTROLLING OUTPUT:

- TYPE OF MATERIAL
- DEPTH OF CUTTING
- SIZE AND TYPE OF BUCKETS
- SKILL OF OPERATOR
- SIZE OF HAULING UNITS & METHOD
- ANGLE OF SWING
- LENGTH OF CRANE BOOM
- JOB CONDITION

LAYOUT OF DRAGLINE MACHINE

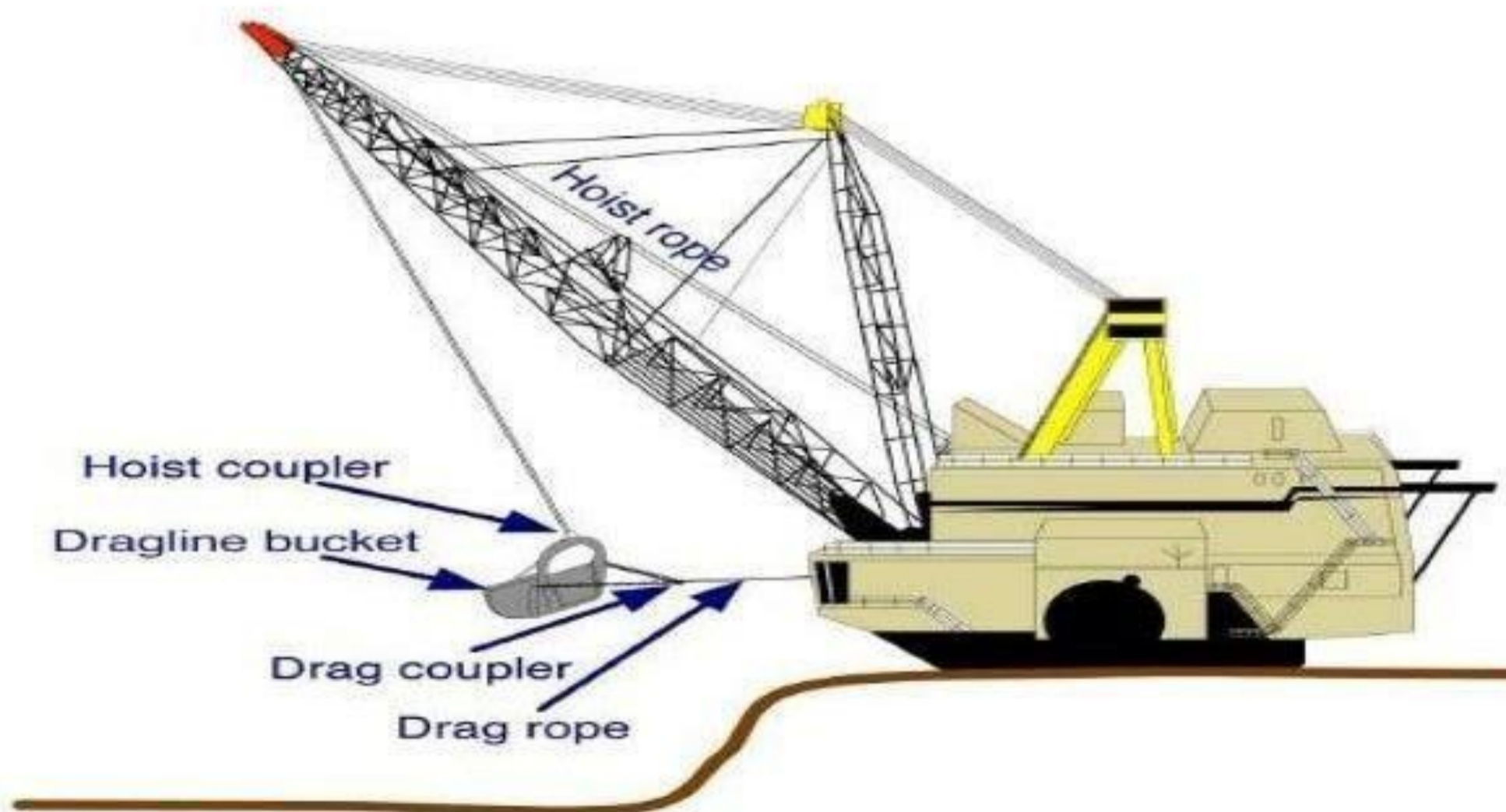

BULL DOZERS

- **VERSATILE EQUIPMENT- ESSENTIALLY A HEAVY STEEL BLADE MOUNTED ON THE FRONT OF TRACTOR.**

CLASSIFICATION BASED ON:

POSITION OF BLADES	- PERPENDICULAR BLADES - BLADES AT AN ANGLE
MOUNTING	- WHEEL MOUNTED - CRAWLER MOUNTED
CONTROL	- CABLE CONTROL - HYDRAULIC CONTROL

CONSTRUCTION:

- ❖ **CONSIST OF HEAVY BLADE WITH CONCAVE PROFILE.**
- ❖ **BLADE IS ATTACHED TO THE BODY WITH TWO ARMS, A SUPPORTING FRAME & HELD BY TWO PUSH ARMS**

APPLICATION:

- ❖ **SPREADING EARTH FILL**
- ❖ **CLEARING, OPENING UP PILOT ROADS**
- ❖ **BACK FILLING TRENCHES**
- ❖ **CLEARING CONSTRUCTION SITES**



Types of bulldozer blade

Dozer Blades

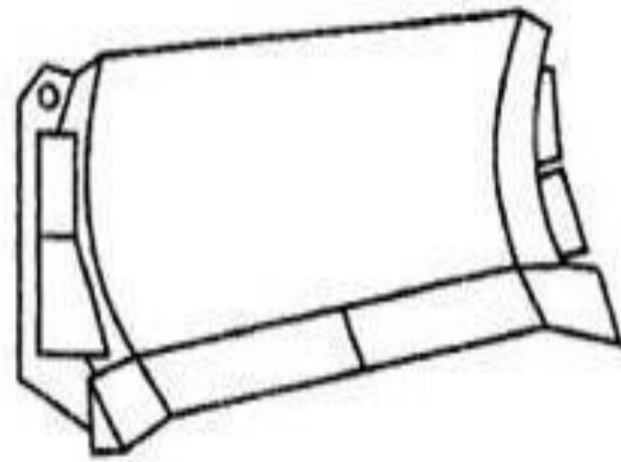

Straight blade

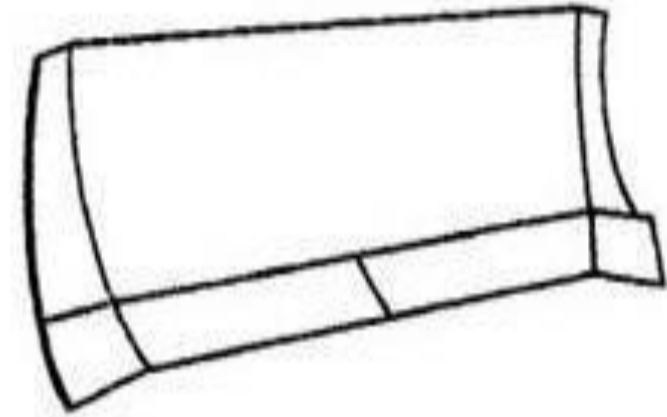

Angle blade

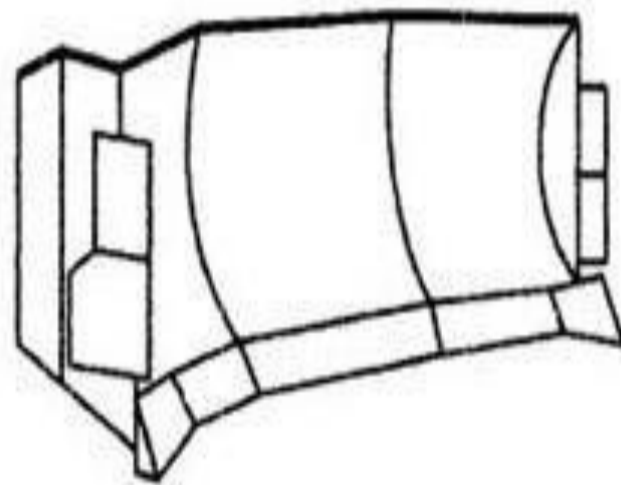

Universal blade

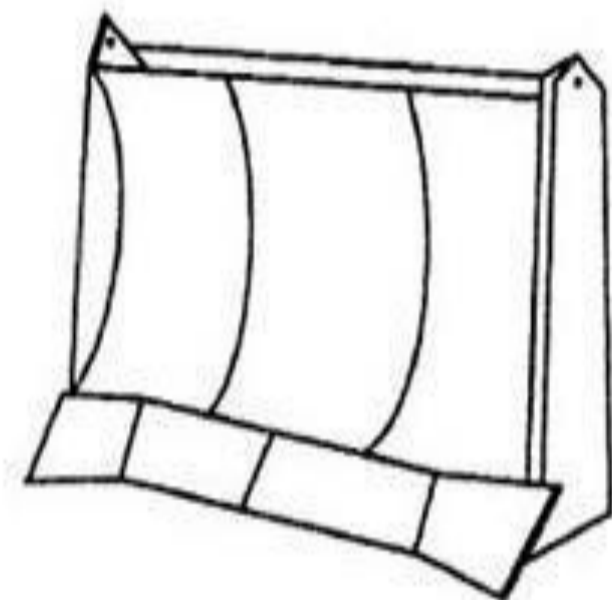

Cushion blade

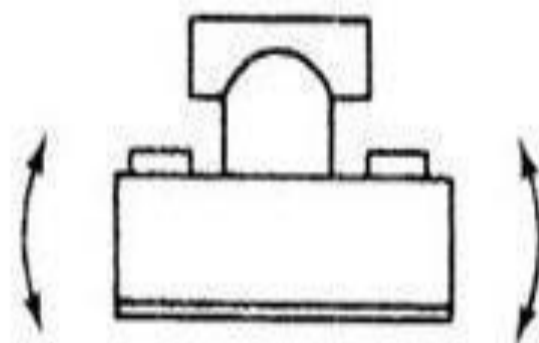

Tilting



Pitching

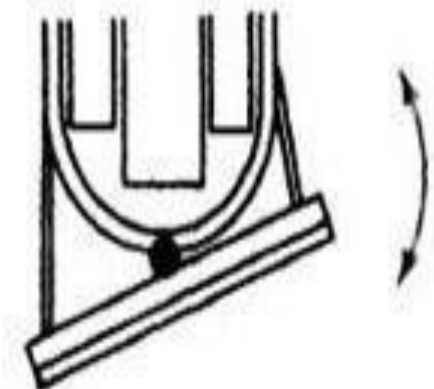

Angling

Classified on the basis of running gear:

- Crawler type
- Wheel type

Crawler Dozer	Wheel Dozer
Work on variety of soil	Good on firm soils and concrete
Work over almost terrain	Best for level and downhill work wet weather
Good for short work distances	Good for long travel distances
Can handle tight soil	Best in handling loose soils
Slow return speeds, 5-10 mph	Fast Return speeds, 8 -26 mph
Can push large blade loads	Can handle only moderate blade loads

TRACTORS

□ MULTI PURPOSE MACHINES MAINLY USED FOR PULLING AND PUSHING OTHER MACHINES FOR AGRICULTURAL PURPOSES.

TYPES:

1. WHEEL TYPE (<50 km/Hr)
2. CRAWLER TYPE (<12 km/Hr)

APPLICATIONS:

- ❖ CLEARING & EXCAVATING MACHINERY
- ❖ HAULING & CONVEYING MACHINERY

CRAWLER TRACTOR



WHEEL TRACTOR



COMPARISON BETWEEN CRAWLER AND WHEELED TRACTORS

CRAWLER TYPE	WHEELED TYPE
1. Slow speed	1. Greater speed
2. More compact and powerful and can handle heavier jobs	2. Can handle only lighter jobs
3. Costly	3. Cheaper
4. Cost of operation and maintenance is high	4. Operational and maintenance cost is less
5. Stick control for steering	5. Wheel steering control
6. Moves on rough roads only	6. Moves on rough as well as good roads
7. Used for short distances	7. Used for longer distances
8. Requires skillful operation, maintenance and repairs	8. Lesser skills required for operations, maintenance and repairs

EARTH COMPACTION EQUIPMENTS

- 1. SMOOTH – WHEEL ROLLERS**
- 2. SHEEP – FOOT ROLLERS**
- 3. PNEUMATIC TYRED ROLLERS**

SMOOTH – WHEEL ROLLERS:

- **PLAIN STEEL ROLLERS**
- **SELF – PROPELLED (5 TO 25 TONNES)**
- **NO DEEP COMPACTION**
- **REAR WHEELS ARE LARGER IN DIAMETER AND THE FRONT ONES ARE WIDER**
- **DIESEL ENGINE TYPE**
- **COMPACTION IS BY STATIC WEIGHT OF ROLLER**

SUITABILITY:

- **GRANULAR SOILS**
- **SAND**
- **GRAVEL**
- **CRUSHED STONES**

SMOOTH WHEEL ROLLER



SHEEP – FOOT ROLLERS

- HOLLOW STEEL DRUM WITH PROJECTED FEET MOUNTED AT 100 TO 200 MMC/C**
- WEIGHT - 15 TONNES**
- SPEED - 25 KM/HR**
- COMPACTION IS BY KNEADING ACTION**
- IN CONVERTIBLE ROLLERS THE FOOT PLATE CAN BE REMOVED**
- IN TURN FOOT ROLLERS THE INDIVIDUAL SHEEP FOOT CAN BE CHANGED**

SUITABILITY:

CLAY, PREDOMINANTLY COHESIVE AND IMPERVIOUS SOIL

SHEEP – FOOT ROLLERS



PNEUMATIC TYRED ROLLERS

- ✓ **CONSISTS OF A BASE PLATFORM MOUNTED BETWEEN TWO AXLES**
- ✓ **TRACKS OF THE REAR WHEEL LIE INBETWEEN THE TRACKS OF THE FRONT WHEEL**
- ✓ **COMPACTION IS BY CONTROLLING THE GROUND CONTACT PRESSURE**
- ✓ **WEIGHT OR WIDTH OF THE WHEEL CAN BE SUITABLY INCREASED**

SUITABILITY:

FINE GRAINED AND WELL GRADED SANDS

PNEUMATIC TYRED ROLLER



The Cost of Owning and Operating Construction Equipment:

There are several methods of determining the probable cost of owning and operating construction equipment. No known method will give exact costs under all operating conditions. At best the estimate is only a close approximation of the cost. Kept records for equipment previously used should give information which may be used as a guide for the particular equipment it was used under the same conditions. Factors that affect the cost of owning and operating construction equipment include:

1. The cost of the equipment delivered to the owner.
2. The severity of the conditions under which the equipment is used.
3. The number of hours the equipment is used per year.
4. The number of years the equipment is used.
5. The care with which the owner maintains and repairs the equipment.
6. The demand for used equipment when it is sold, which will affect the salvage value.

When it is necessary to estimate the cost of owning and operating construction equipment prior to purchasing it, cost records, based on past performance generally will not be available, therefore the following costs should be considered:

1. Ownership Costs:
2. Depreciation cost.
3. Investment Cost.

Economical Life of Construction Equipment:

The owner of construction equipment should be interested in obtaining the lowest possible cost per unit of production. In order to accomplish this objective he must follow an informed program of equipment replacement. If the owner replaces it too soon, he will experience an unnecessary capital loss, whereas, if he waits too long, the equipment will have passed its period of economic operation. In order to determine the most economical time to replace equipment, accurate records of maintenance and repair costs and downtime must be kept for each machine.

The owner must consider all costs related to the ownership and operation of the equipment, and the effect which continued use will have on these costs. The costs to be considered are:

1. Depreciation and replacement.
2. Investment.
3. Maintenance and repairs
4. Downtime.
5. Obsolescence.

An analysis of the effect which hours of usage will have on each of these costs will establish the time at which a machine should be replaced.

Sources of Construction Equipment:

Contractors and other users of construction equipment are concerned with a decision as to whether to purchase or rent equipment. Under certain conditions it is financially advantageous to purchase, whereas under other conditions it is more economical and satisfactory to rent it. There are at least three methods under which a contractor may secure the use of construction equipment:

1. Purchase the equipment.
2. Rent the equipment.
3. Rent the equipment with an option to purchase it at a later date.

The method selected should be the one that will provide the use of the equipment at the lowest total cost. Each of the three methods has both advantages and disadvantages which should be considered prior to making a decision. If the cost was the only factor to be considered, then an analysis of the cost under each method should give the answer. If other factors should be considered, they should be evaluated and applied to the cost as a basis on which to reach a decision. The correct decision for one contractor will not necessarily apply for another contractor.