

# **PNS School of Engineering & Technology**

**Nishamani Vihar, Angulai, Marshaghai.**



**Lecturer's Note**

**On**

**Analog Electronics & OP-AMP**

**(Theory – 2)**

**For**

**4<sup>th</sup> Semester, Electrical Engineering**

**(As per SCTE&VT Syllabus)**

**Prepared By**

***Er. Amarendra Sahoo.***

**H.O.D. Electronics & Telecommunication**

# CONTENTS

## **1. P-N JUNCTION DIODE:**

- 1.1 Semiconductor and its type
- 1.2 P-N Junction Diode
- 1.3 V-I characteristic of PN junction Diode
- 1.4 DC load line
- 1.5 important terms such as Ideal Diode, Knee voltage
- 1.6 Junctions breakdown.
  - 1.6.1 Zener breakdown
  - 1.6.2 Avalanche breakdown
- 1.7 P-N Diode clipping Circuit.
- 1.8 P-N Diode clamping Circuit

## **2. SPECIAL SEMICONDUCTOR DEVICES:**

- 2.1 Transducer
- 2.2 Thermistors
- 2.3 Sensors
- 2.4 Barretters
- 2.5 Zener Diode
- 2.6 Tunnel Diode
- 2.7 PIN Diode

## **3. RECTIFIER CIRCUITS & FILTERS:**

- 3.1 Rectifier and Classification of rectifiers
- 3.2 Analysis of half wave, full wave center tapped and Bridge rectifiers
- 3.3 Filters:
  - 3.3.1 Inductor filter
  - 3.3.2 Capacitor filter
  - 3.3.3 Choke input filter
  - 3.3.4  $\pi$  filter or Capacitor input filter

## **4. TRANSISTORS:**

- 4.1 Principle of Bipolar junction transistor
- 4.2 Different modes of operation of transistor
- 4.3 Current components in a transistor
- 4.4 Transistor as an amplifier
- 4.5 Transistor circuit configuration & its characteristics
  - 4.5.1 CB Configuration
  - 4.5.2 CE Configuration

#### 4.5.3 CC Configuration

### **5. TRANSISTOR CIRCUITS**

5.1 Transistor biasing

5.2 Stabilization

5.3 Stability factor

5.4 Different methods of Transistor Biasing

5.4.1 Fixed Biasing

5.4.2 Emitter Stabilized Biasing

5.4.3 Self Bias or Voltage Divider method

5.4.4 DC bias with collector feedback

### **6. TRANSISTOR AMPLIFIERS & OSCILLATORS:**

6.1 Practical circuit of transistor amplifier

6.2 Transistor load line analysis

6.2.1 DC load line and DC equivalent circuit

6.2.2 AC load line and AC equivalent circuit

6.3 Phase reversal

6.4 H-parameters of transistors

6.5 Generalized approximate model

6.6 Analysis of CB, CE, CC amplifier using generalized approximate model

6.7 Multi stage transistor amplifier

6.7.1 R.C. coupled amplifier

6.7.2 Transformer coupled amplifier

6.8 Feed back in amplifier

6.8.1 General theory of feed back

6.8.2 Negative feedback circuit

6.8.3 Advantage of negative feed back

6.9 Power amplifier and its classification

6.9.1 Difference between voltage amplifier and power amplifier

6.9.2 Transformer coupled class A power amplifier

6.9.3 Class A push – pull amplifier

6.9.4 Class B push – pull amplifier

6.10 Oscillators

6.10.1 Types of oscillators

6.10.2 Essentials of transistor oscillator

6.10.3 Principle of operation of tuned collector, Hartley, colpitt, phase shift, wein- bridge oscillator (no mathematical derivations)

## **7. FIELD EFFECT TRANSISTOR:**

- 7.1 FET and Classification of FET
- 7.2 Advantages of FET over BJT
- 7.3 Principle of operation of BJT
- 7.4 FET parameters (no mathematical derivation)
- 7.5 Biasing of FET

## **8. OPERATIONAL AMPLIFIERS:**

- 8.1 General circuit simple of OP-AMP and IC – CA – 741 OPAMP
- 8.2 Operational amplifier stages
- 8.3 Equivalent circuit of operational amplifier
- 8.4 Open loop OP-AMP configuration
- 8.5 OPAMP with feedback
- 8.6 Inverting OP-AMP
- 8.7 Non inverting OP-AMP
- 8.8 Voltage follower & buffer
- 8.9 Differential amplifier
  - 8.9.1 Adder or summing amplifier
  - 8.9.2 Subtractor
  - 8.9.3 Integrator
  - 8.9.4 Differentiator
  - 8.9.5 Comparator

## **COURSE OUTCOME (CO):**

**After the completion of the course the students are able to:**

1. Understand the working and current voltage characteristic of semiconductor devices.
2. Analyze different parameters of various rectifier circuits.
3. Explain the working of different types of filter circuit.
4. Develop the ability to understand the working of different BJT and FET circuits.
5. Describe different method of biasing of BJT and FET.
6. Analyze DC circuits and relate AC models with their physical operation.
7. Explain the working and frequency response of different types of transistor amplifier.
8. Develop knowledge of operational amplifiers and their application.
9. Observe the effect of feedback circuits and explain the working of different types of oscillators.

# UNIT-1: PN JUNCTION DIODE

## 1.1 SEMICONDUCTOR:

Semiconductors (*e.g. germanium, silicon etc.*) are those substances whose electrical conductivity lies in between conductors and insulators. In terms of energy band, the valence band is almost filled and conduction band is almost empty. Further, the energy gap between valence and conduction bands is very small. The semiconductor has:

- Filled valence band
- Empty conduction band
- Small energy gap or forbidden gap ( 1 eV) between valence and conduction bands.
- Semiconductor virtually behaves as an insulator at low temperatures. However, even at room temperature, some electrons cross over to the conduction band, imparting little conductivity (i.e. conductor).

### Types of semiconductors:-

Semiconductors are classified into two types:-

- ❖ Intrinsic semiconductors
- ❖ Extrinsic semiconductors
- Extrinsic semiconductors are also of two types:-
  - P-type semiconductors
  - N-type semiconductors

#### **Intrinsic semiconductors**

- A semiconductor in an extremely pure form is known as an intrinsic semiconductor. When electric field is applied across an intrinsic semiconductor, the current conduction takes place by two processes i.e. by free electrons and holes.
- The free electrons are produced due to the breaking up of some covalent bonds by thermal energy. At the same time, holes are created in the covalent bonds.
- Under the influence of electric field, conduction through the semiconductor is by both free electrons and holes. Therefore, the total current inside the semiconductor is the sum of currents due to free electrons and holes.

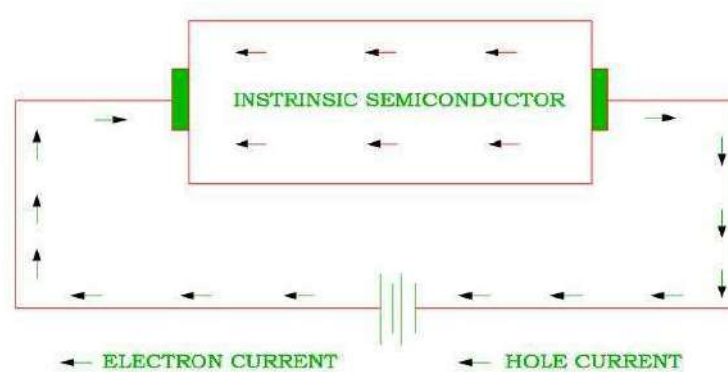
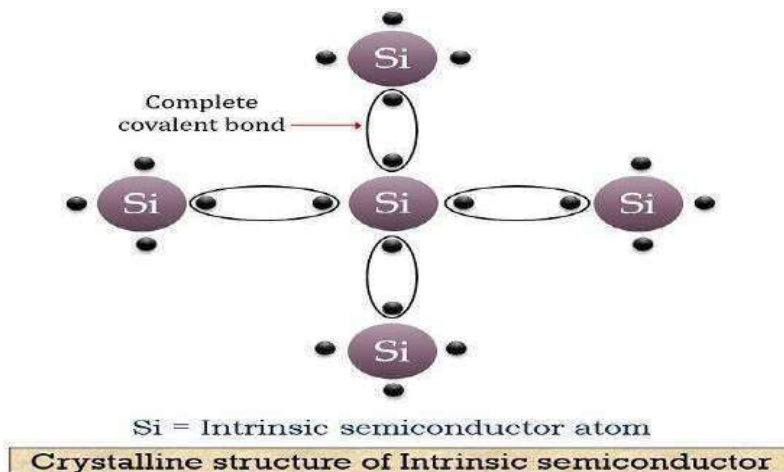

## Extrinsic semiconductors

An extrinsic semiconductor is a semiconductor doped by addition of small amount impurity. The process of adding impurities to a semiconductor is known as doping. The purpose of adding impurity is to increase either the number of free electrons or holes in the semiconductor crystal. Depending upon the type of impurity added, extrinsic semiconductors are classified into:

- n-type semiconductor
- p-type semiconductor

## N-type semiconductors

When a small amount of pentavalent impurity is added to a pure semiconductor, it is known as n-type semiconductor. Examples of pentavalent impurities are arsenic,

antimony, Bismuth and Phosphorous etc. Such impurities are known as donor impurities because they donate or provide free electrons to the semiconductor crystal. Electrons are said to be the majority carriers whereas holes are the minority carriers.

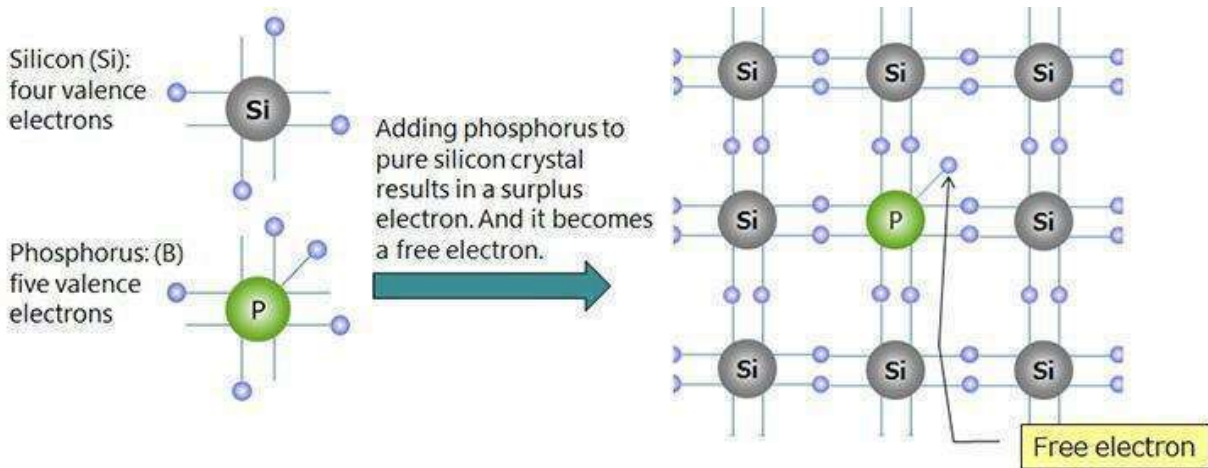

### P-type semiconductors

When a small amount of trivalent impurity is added to a pure semiconductor, it is called p-type Semiconductor. Examples of trivalent impurities are gallium, indium, boron etc. The addition of trivalent impurity provides a large number of holes in the semiconductor. Such impurities are known as acceptor impurities because the holes created can accept the electrons. In a p type semiconductor holes are the majority carriers and electrons are the minority carriers.

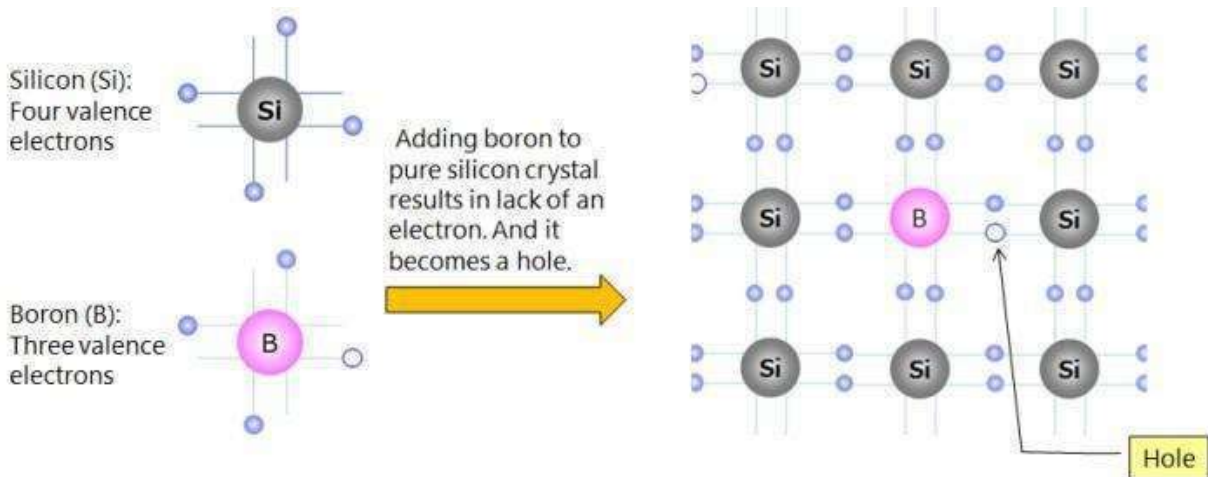



## 1.2 PN JUNCTION:-

### Zero Biased Junction Diode

When a diode is connected in a Zero Bias condition, no external potential energy is applied to the PN junction. However if the diodes terminals are shorted together, a few holes (majority carriers) in the P-type material with enough energy to overcome the potential barrier will move across the junction against this barrier potential. This is known as the "Forward Current" and is referenced as  $I_F$ . Likewise, holes generated in the N-type material (minority carriers), find this situation favorable and move across the junction in the opposite direction. This is known as the "Reverse Current" and is referenced as  $I_R$ . This transfer of electrons and holes back and forth across the PN junction is known as diffusion.

The potential barrier that now exists discourages the diffusion of any more majority carriers across the junction. However, the potential barrier helps minority carriers (few free electrons in the P-region and few holes in the N-region) to drift across the junction.

Then an "Equilibrium" or balance will be established when the majority carriers are equal and both moving in opposite directions, so that the net result is zero current flowing in the circuit. When this occurs the junction is said to be in a state of "Dynamic Equilibrium".

The minority carriers are constantly generated due to thermal energy so this state of equilibrium can be broken by raising the temperature of the PN junction causing an increase in the generation of minority carriers, thereby resulting in an increase in leakage current but an electric current cannot flow since no circuit has been connected to the PN junction.

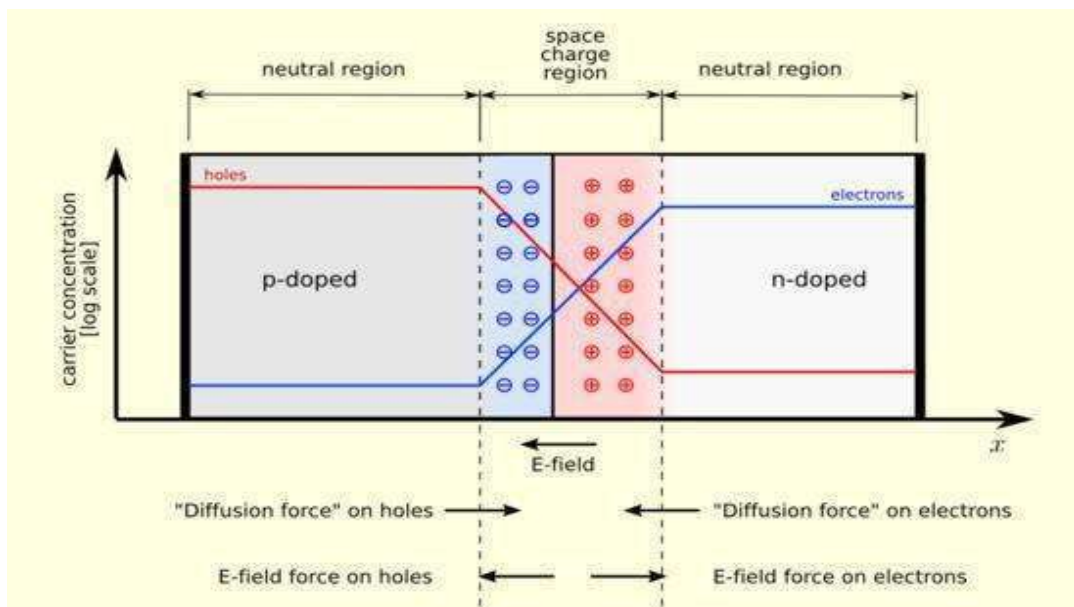

# Diode Symbol

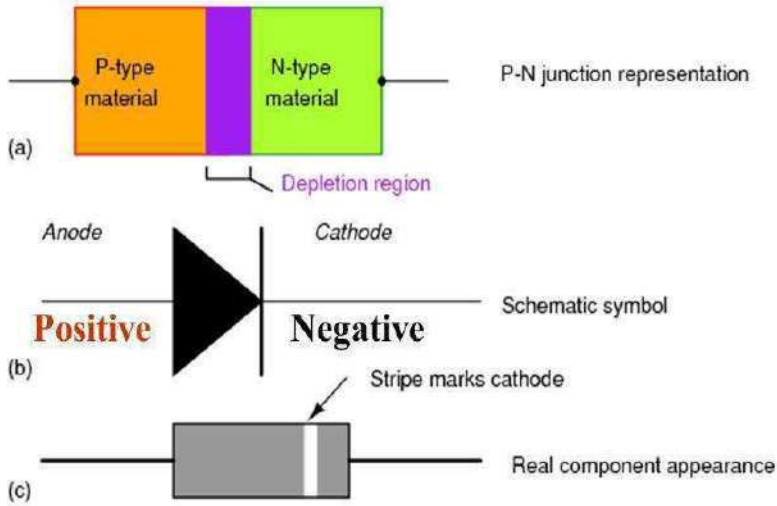

## FORWARD BIASING:-

- A P-N junction diode is said to be forward biased when the positive terminal of a cell or battery is connected to the p-side of the junction and the negative terminal to the  $n$  side.
- When diode is forward-biased the depletion region narrows and consequently, the potential barrier is lowered.
- This causes the majority charge carriers of each region to cross into the other region.
- The electrons travel from the n-side to the p-side and go to the positive terminal of the battery.
- The holes that travel from the p-side to the n-side combine with the electrons injected into the n-region from the negative terminal of the battery.

With the increase in forward bias voltage, the depletion region eventually becomes thin, thus reducing electrical resistance.

- This causes electrons to pass through the junction resulting in an exponential rise in current.
- This way the diode conducts when forward-biased.

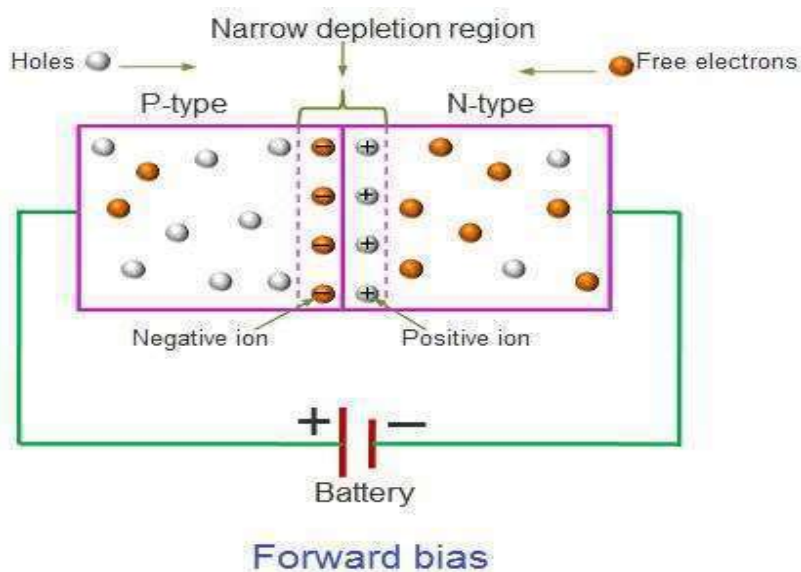

## REVERSE BIASING:-

- A pn-junction diode is said to be reverse biased when the positive terminal of a cell or battery is connected to the n-side of the junction and the negative terminal to the p-side.
- When reverse biased, the depletion region widens and the potential barrier is increased.
- The polarity of the battery extracts the majority charge carriers of each region.
- The holes in the p-region from the electrons injected into the p-region from the negative terminal of the battery.

- The electrons in the n-region go to the positive terminal of the battery.
- This way, the majority charge carrier concentration in each region decreases against the equilibrium values and the reverse biased junction diode has a high resistance.
- Thus, the diffusion current across the junction becomes zero.
- Thus, the diode does not conduct when reverse biased and is said to be in a quiescent or non-conducting state i.e., it acts as an open switch.

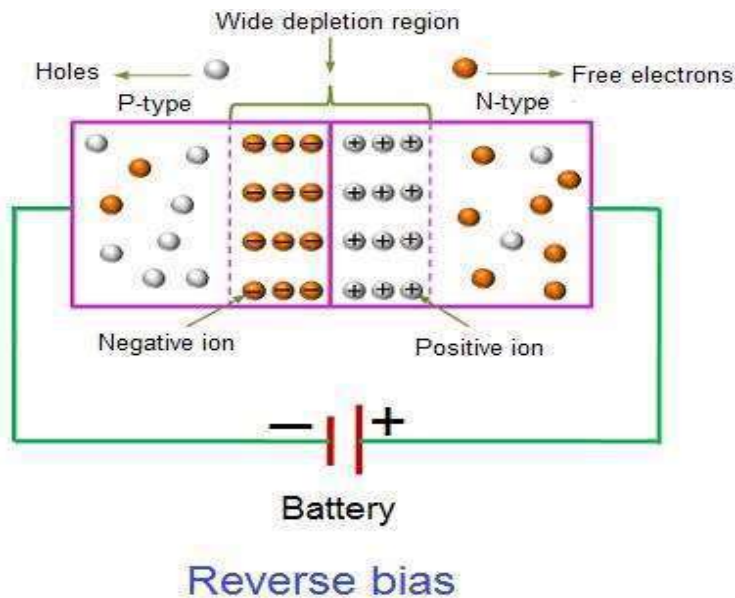

### 1.3 VI CHARACTERISTICS OF PN JUNCTION:-

Volt-ampere (V-I) characteristics of a pn junction or semiconductor diode is the curve between voltage across the junction and the current through the circuit.

Normally the voltage is taken along the x-axis and current along y-axis.

The circuit connection for determining the V-I characteristics of a pn junction is shown in the figure below.

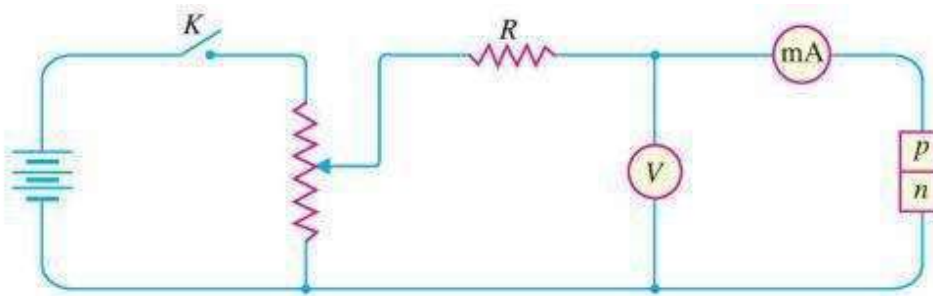

The characteristics can be explained under three cases, such as :

1. Zero bias
2. Forward bias
3. Reverse bias

### Case-1: Zero Bias

In zero bias condition, no external voltage is applied to the pn junction i.e. the circuit is open at K.

Hence, the potential barrier at the junction does not permit current flow.

Therefore, the circuit current is zero at  $V=0$  V, as indicated by point O in figure below.

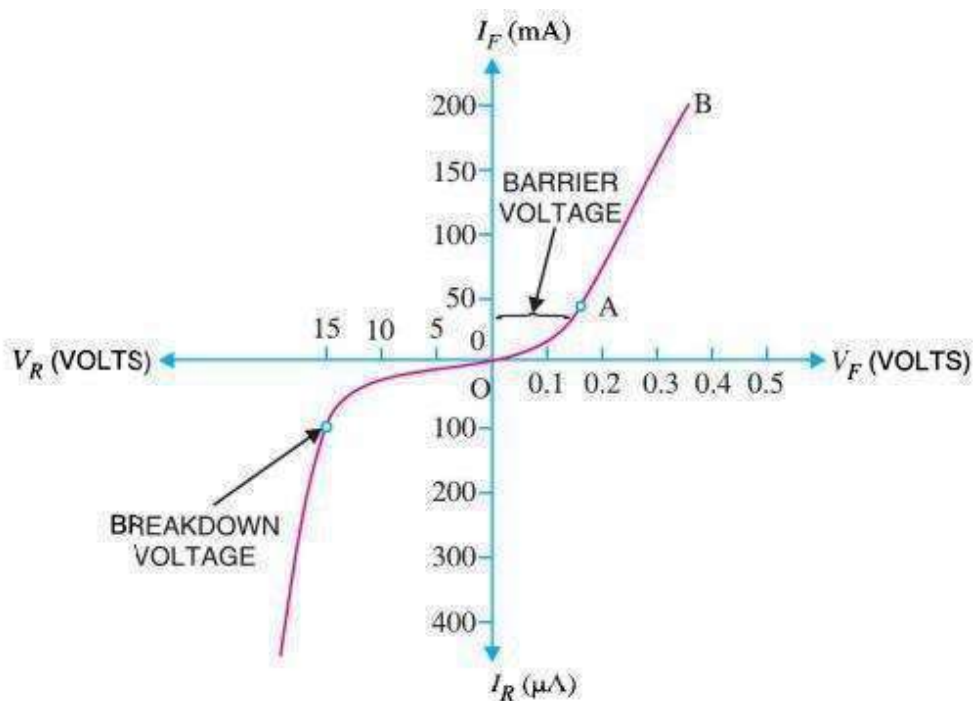

### **Case-2: Forward Bias**

In forward biased condition, p-type of the pn junction is connected to the positive terminal and n-type is connected to the negative terminal of the external voltage.

This results in reduced potential barrier.

At some forward voltage i.e. 0.7 V for Si and 0.3 V for Ge, the potential barrier is almost eliminated and the current starts flowing in the circuit.

From this point, the current increases with the increase in forward voltage. Hence a curve OB is obtained with forward bias as shown in figure above.

From the forward characteristics, it can be noted that at first i.e. region OA, the current increases very slowly and the curve is non-linear. It is because in this region the external voltage applied to the pn junction is used in overcoming the potential barrier.

However, once the external voltage exceeds the potential barrier voltage, the potential barrier is eliminated and the pn junction behaves as an ordinary conductor. Hence, the curve AB rises very sharply with the increase in external voltage and the curve is almost linear.

### **Case-3: Reverse Bias**

In reverse bias condition, the p-type of the pn junction is connected to the negative terminal and n-type is connected to the positive terminal of the external voltage.

This results in increased potential barrier at the junction.

Hence, the junction resistance becomes very high and as a result practically no current flows through the circuit.

However, a very small current of the order of  $\mu\text{A}$ , flows through the circuit in practice. This is known as reverse saturation current ( $I_s$ ) and it is due to the minority carriers in the junction.

As we already know, there are few free electrons in p-type material and few holes in n-type material. These free electrons in p-type and holes in n-type are called minority carriers.

The reverse bias applied to the pn junction acts as forward bias to their minority carriers and hence, small current flows in the reverse direction.

If the applied reverse voltage is increased continuously, the kinetic energy of the minority carriers may become high enough to knock out electrons from the semiconductor atom.

At this stage breakdown of the junction may occur. This is characterized by a sudden increase of reverse current and a sudden fall of the resistance of barrier region. This may destroy the junction permanently.

### **DC LOAD LINE-**

A circuit supplied with dc power as the external source of the circuit. There exist both alternating and direct currents in the circuit. The reactive components of the circuits are made zero and the straight line is drawn above the voltage-current characteristics curves. Hence these results in the formation of intersecting point referred to an operating point. The straight that is drawn for this purpose is defined as the DC load line.

### **DC Load Line of a Diode and Its Equation**

DC load line for a non-linear device is drawn by making the reactive components as zero. Hence a diode is considered as a non-linear device and its voltage and current characteristics are exponentially related to each other. The formation of the intersection point for the characteristic curve and the straight line or dc-load line can be analyzed better by considering the example for the diode as in forward bias condition.

Let us consider a diode connected to the resistor( $R$ ), source of voltage ( $V_{DD}$ ) in series. The diode is connected in forward bias so that the forward current and the forward voltages flowing through the circuit. As per the Kirchhoff's current law, the current flowing through the diode ( $I_D$ ) and the resistor ( $I_R$ ) is equal.

$$I_D = I_R$$

Analysis of the circuit is done by applying Kirchhoff's voltage law (KVL). This law results in the formation of the final equation for the dc load line. Here the dc voltage is the biasing voltage of the circuit by keeping any further reactive components as zero.

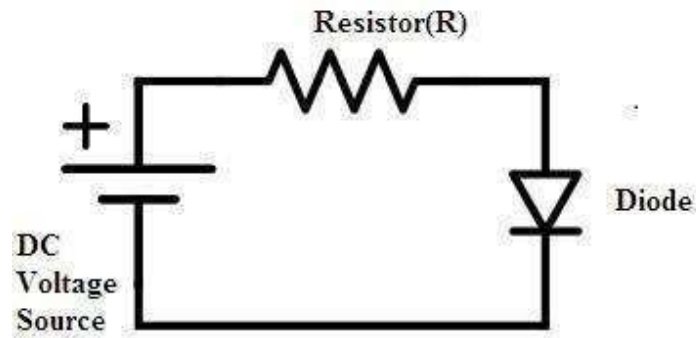

### Diode-operating-in-forward-bias-for-the-analysis-of-dc-load

Once the Kirchhoff's voltage law is applied to the circuit an equation is obtained for voltages and currents in the circuit.

$$V_{DD} = V_D + I_D R$$

$$V_D = I_D R - V_{DD}$$

Where  $V_{DD}$ , is the applied dc source voltage and  $V_D$  is the voltage across the diode. Hence the above can be considered as the equation for the diode. The voltage and current characteristics of the diode in forward bias condition can be drawn. By our previous analysis on the condition of the diode in forward bias applied a voltage and the generated current in the circuit are exponentially related to each other.

After a certain cut-off voltage, the diode starts operating in forward bias condition. To this slope, the technique is considered and a straight line on the v-i characteristics is drawn. The slope here for the above general circuit for the diode is  $V_{DD}/R$ .

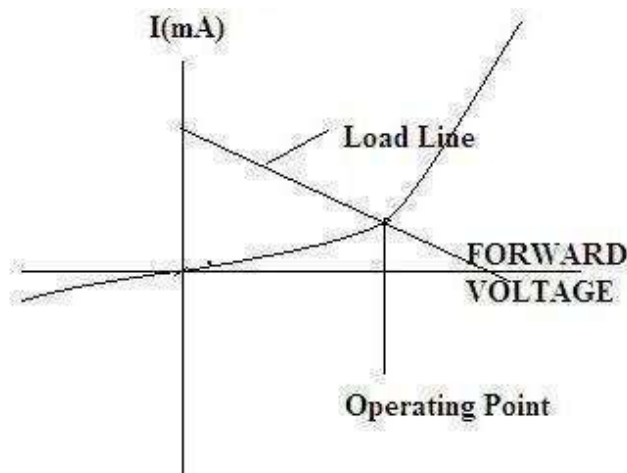

### Dc-load-line-and-the-formation-of-operating-point



In this way, the analysis for the dc-load line is done for the non-linear device like a diode. Depending on the type of non-linear device some part of the analysis differs but the technique remains the same. This type of method comes under the graphical analysis because here the characteristics curve is considered for the formation of the dc-load line.

## **1.5 IMPORTANT TERMS SUCH AS IDEAL DIODE, KNEE VOLTAGE**

### **Ideal Diode:**

An ideal diode is one kind of an electrical component that performs like an ideal conductor when voltage is applied in forward bias and like an ideal insulator when the voltage is applied in reverse bias. So when +ve voltage is applied across the anode toward the cathode, the diode performs forward current immediately. When a voltage is applied in reverse bias, then it performs no current at all. This diode operates like a switch. When the diode is in forward bias, it works like a closed switch. Whereas, if an ideal diode is in reverse bias, then it works like an open switch.

### **Knee Voltage:**

The forward voltage at which the current through the junction starts increasing rapidly, is called knee voltage or cut-in voltage. It is generally 0.6v for a diode.

## **1.6 JUNCTIONS BREAKDOWN:**

- ✓ The Avalanche Breakdown and Zener Breakdown are two different mechanisms by which a PN junction breaks.
- ✓ The Zener and Avalanche breakdown both occur in diode under reverse bias.
- ✓ The avalanche breakdown occurs because of the ionization of electrons and hole pairs whereas the Zener diode occurs because of heavy doping.

### **1.6.1 AVALANCHE BREAKDOWN:**

The mechanism of avalanche breakdown occurs because of the reverse saturation current. The P-type and N-type material together forms the PN-junction. The depletion region develops at the junction where the P and N-type material contact. The P and N-type materials of the PN junction are not perfect, and they have some impurities in it, i.e., the p-type material has some electrons, and the N-type material has some hole in it. The width of the depletion region varies. Their width depends on the bias applied to the terminal of P and N region. The reverse bias increases the electrical field across the depletion region. When the high electric field exists across the depletion, the velocity of minority charge carrier crossing the depletion region increases. These carriers collide with the atoms of the crystal. Because of the violent collision, the charge carrier takes out the electrons from the atom. The collision increases the electron-hole pair. As the electron-hole induces in the high electric field, they are quickly separated and collide with the other atoms of the crystals. The process is continuous, and the electric field becomes so much

higher than the reverse current starts flowing in the PN junction. The process is known as the Avalanche breakdown. After the breakdown, the junction cannot regain its original position because the diode is completely burnt off.

### 1.6.2 ZENER BREAKDOWN:

The PN junction is formed by the combination of the p-type and the n-type semiconductor material. The combination of the P-type and N-type regions creates the depletion region. The width of the depletion region depends on the doping of the P and N-type semiconductor material. If the material is heavily doped, the width of the depletion region becomes very thin. The phenomenon of the Zener breakdown occurs in the very thin depletion region. The thin depletion region has more numbers of free electrons. The reverse bias applied across the PN junction develops the electric field intensity across the depletion region. The strength of the electric field intensity becomes very high. The electric field intensity increases the kinetic energy of the free charge carriers. Thus the carrier starts jumping from one region to another. These energetic charge carriers collide with the atoms of the p-type and n-type material and produce the electron-hole pairs. The reverse current starts flowing in the junction because of which depletion region becomes entirely vanishes. This process is known as the Zener breakdown. In Zener breakdown, the junction is not completely damaged. The depletion region regains its original position after the removal of the reverse voltage. The voltage of Zener breakdown is less than the Avalanche breakdown.

### Breakdown Characteristic Graph

The graphical representation of the Avalanche and Zener breakdown is shown in the figure below.

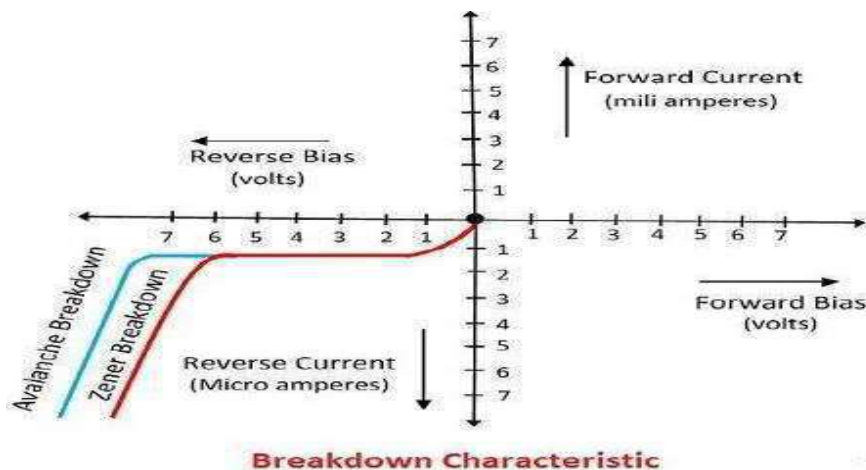

### 1.7 P-N DIODE CLIPPER CIRCUIT:

Clipper circuits are the circuits that clip off or remove a portion of an input signal, without causing any distortion to the remaining part of the waveform. These are also known as clippers, clipping circuits, limiters, slicers etc.

Clippers are basically wave shaping circuits that control the shape of an output waveform. It consists of linear and non-linear elements but does not contain energy storing elements.

The basic operation of a diode clipping circuits is such that, in forward biased condition, the diode allows current to pass through it, clamping the voltage. But in reverse biased condition, no any current flows through the diode, and thus voltage remains unaffected across its terminals.

Clipper circuits are basically termed as protection devices. As electronic devices are voltage sensitive and voltage of large amplitude can permanently destroy the device. So, in order to protect the device clipper circuits are used.

Usually, clippers employ resistor–diode combination in its circuitry.

### Classification of Clipper circuits

Clippers are basically classified in the following categories:

- Series positive Clipper circuit

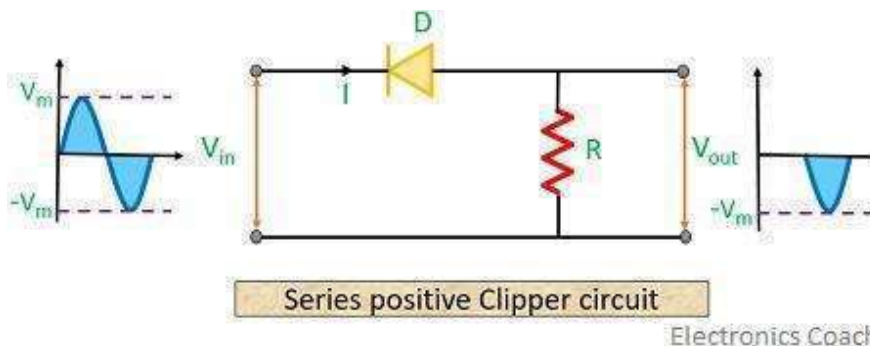

Let's have a look at the circuit diagram of a series positive clipper. Here, the diode is connected in series with the output thus it is named so.

The positive half of the input waveform reverse biases the diode. Thus it acts as an open switch and all the applied input voltage drops across the diode. Resultantly providing no output voltage for positive half of the input waveform.

For the negative half of the input waveform, the diode is in the forward biased state. Thus it acts as a closed switch causing no any voltage drop at the diode.

Hence input voltage will appear across the resistor, ultimately at the output of the circuit.

- Series negative clipper circuit

The circuit below shows the figure of a series negative clipping circuit.

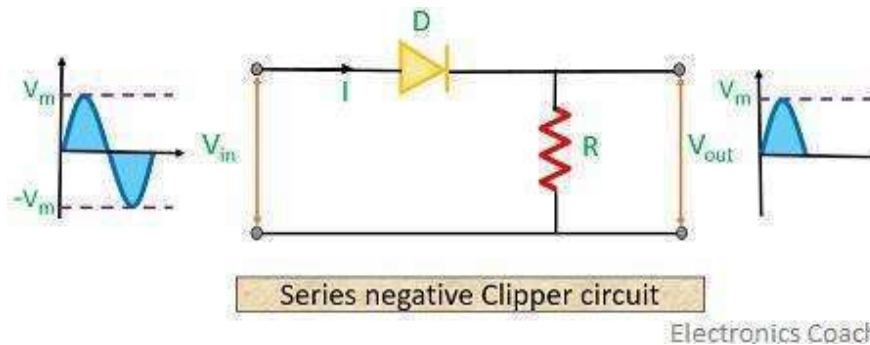

Here, during the positive half cycle of input waveform, the diode becomes forward biased, thus ensuring a closed circuit. Due to which current appears across the resistor of the circuit.

For negative half of the input waveform, the diode now becomes reverse biased acting as an open switch. This causes no current to flow through the circuit. Resultantly providing no output for negative half of the input waveform.

- Series positive clipper circuit with bias

Whenever there is a need to clip or remove a certain portion of positive half of input waveform, series positive clippers with biasing are needed.

- The case of a Positively biased circuit:

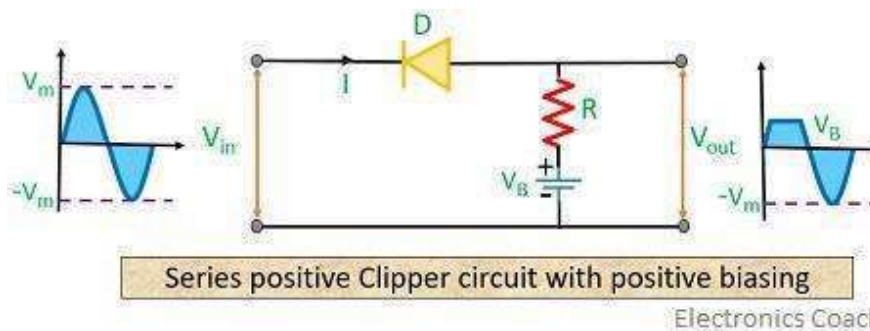

Here in the circuit shown above, we can see that the diode is in forward bias condition concerning the battery. But positive half of the input waveform puts the diode in reverse biased condition.

The diode will conduct until the supply voltage is less than the battery potential. As battery potential dominates the supply voltage, the signal appears at the positive half of output

waveform. But as the supply voltage exceeds the battery potential, the diode is now reverse biased. Resultantly no further current will flow through the diode.

For the negative half cycle of the input waveform, the diode is forward biased concerning both supply voltage and battery potential. Hence, we achieve a complete negative half cycle at the output waveform.

## 2. The case of a negatively biased circuit:

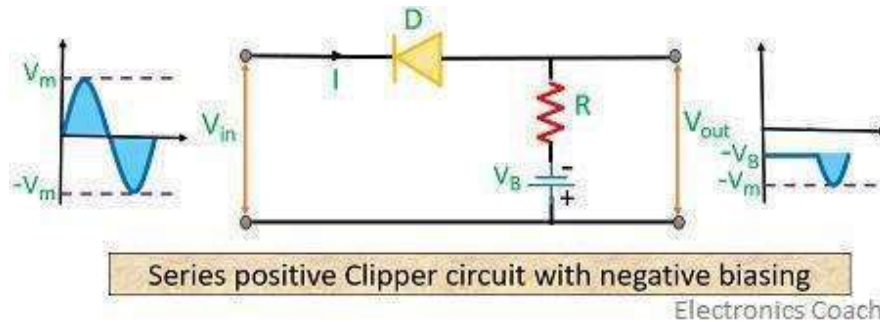

As we can see in the circuit shown above, the diode is reverse bias due to both supply voltage and battery potential. This cuts off the complete positive half of the input waveform.

But during the negative half cycle of the input waveform, the diode is in forward biased condition due to supply voltage but is reverse biased by the battery potential.

Here also initially when battery dominates the supply voltage, the diode is in reverse biased condition. But, as the supply voltage becomes greater than the battery potential, the diode will automatically come in forward biased condition. Thus, the signal starts to appear at the output.

- Series negative clipper circuits with bias

Whenever there is a need to clip or remove a certain portion of the negative half of the input waveform, then series negative clipper circuits with biasing is needed.

## 1. The case of a positively biased circuit:

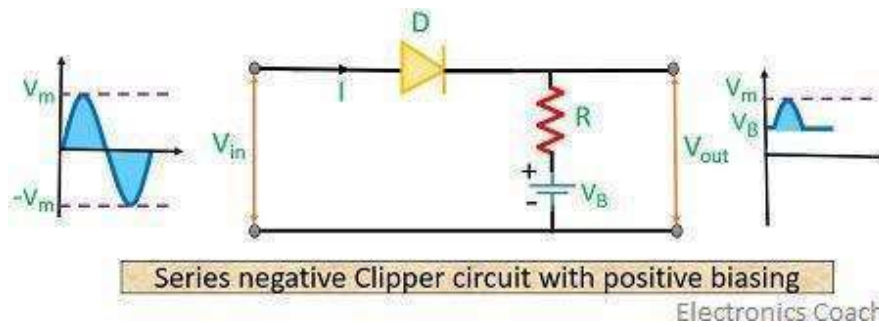

Here in the circuit, we have noticed that for the positive half of input waveform, the diode becomes forward bias. However, the battery potential causes the diode to be at the reverse biased condition.

In the beginning, the battery potential is higher than the supply voltage. Thus causing no current to flow through the circuit at that time. But when the positive half supply voltage exceeds the battery potential then diode becomes forward biased and starts conduction. Hence signal appears at the output.

The negative half cycle of the input waveform causes the diode to be reverse biased. At the same time applied battery potential reverse biases the diode. Thus no any signal is achieved at the output in such a condition.

## 2. The case of negatively biased circuits:

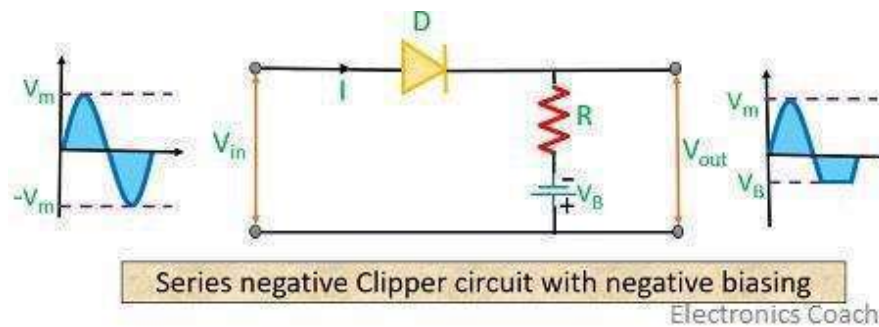

For the positive half of the input cycle, supply voltage and battery potential both cause the diode to be in forward biased condition. Thus complete output for the positive half is achieved in this case.

But in the case of the negative half cycle of the input waveform, the diode is now in reverse biased condition. At the same time due to battery potential, the diode is forward biased. So, until the battery potential is greater than the supply voltage, current flows through the circuit. Hence output is achieved.

But as the supply voltage becomes greater than the battery potential, the diode will now become reverse biased and hence conduction stops. Ultimately no any signal appears for that portion of the input waveform at the output.

- Shunt positive Clipper circuits

Now, let's have a look at the circuit of shunt clippers shown below

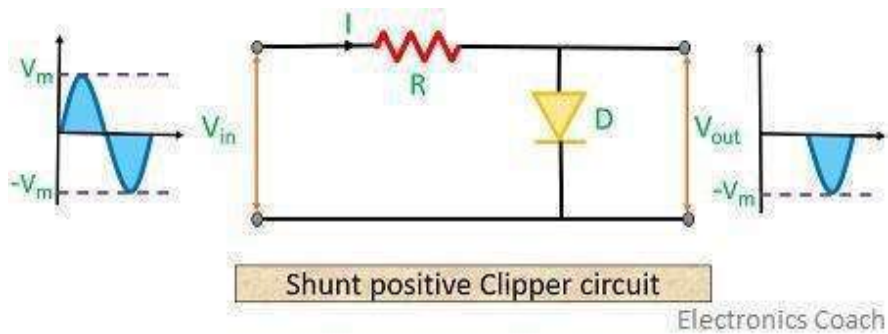

Here, the diode is connected in parallel with the load. Hence its working principle is exactly opposite to that of the shunt clippers. In shunt positive clippers, the output signal is observed only when the diode is reverse biased.

During the positive half of the input signal, the diode gets forward biased due to which the current flows through the diode. Hence, due to the parallel combination of diode and load, no current is observed at the load. Resultantly no output waveform for the positive half is achieved.

On the contrary, during the negative half of the input signal, the diode gets reverse biased. Thus no current flows through it, and the output current is observed at the load. So, for the negative half of input, the entire negative half appears at the output.

- Shunt negative Clippers circuits

Let's have a look at the figure shown below of shunt negative clippers.

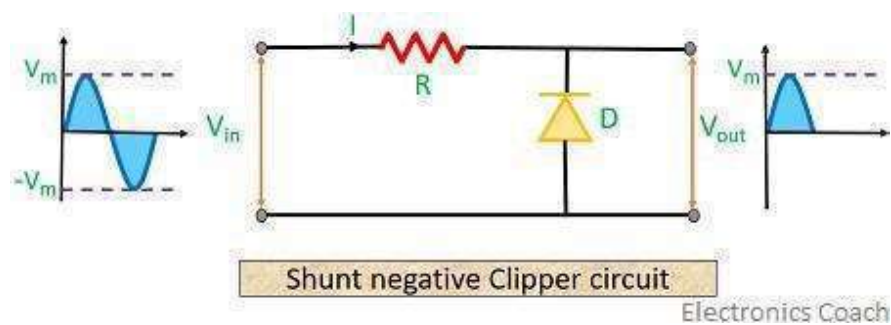

For negative shunt clippers, during the positive half of input, the diode gets reverse biased. Thus no current flows through it, and the output current is observed at the load.

Hence output signal is achieved for positive half of the input signal.

During the negative half of the input signal, the diode gets forward biased and hence no load current is achieved. Ultimately no output is observed for negative half of the input signal.

- Shunt positive clipper circuits with bias

Here, we will discuss both the cases of positive and negative biasing separately as we have done in series clipper with bias.

1. The case of positively biased circuits:

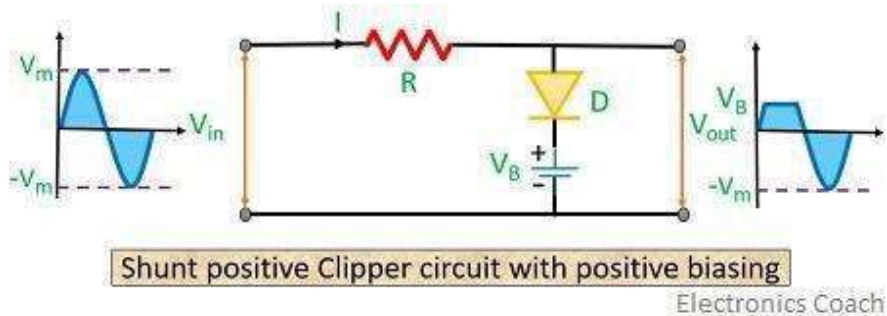

During the positive half of the input cycle, the diode gets forward biased but at the same time battery potential causes the diode to be at the reverse biased condition.

Until the battery potential is greater than the supply voltage, the reverse biased diode by the battery potential does not allow the flow of current through it. Hence current flows through load and signal is observed at the output. But when input voltage increases more than the battery potential, the diode becomes forward biased due to the supply voltage. Hence, allowing current to flow through the diode and no output is achieved.

In case of negative half of the input cycle, both battery potential and supply voltage reverse biases the diode. Hence we get a complete negative half cycle at the output.

2. The case of negatively biased circuits:



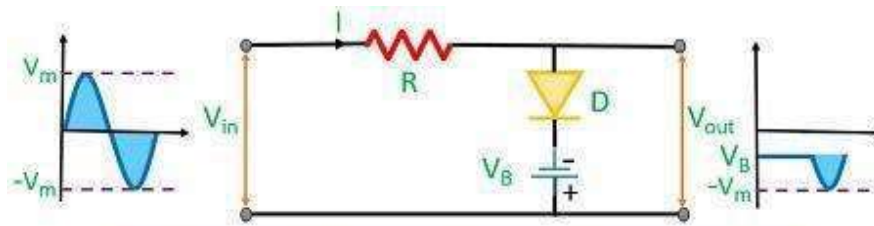

Shunt positive Clipper circuit with negative biasing

Electronics Coach

In this case, the negative half of the input cycle and the applied battery potential both causes the diode to be forward biased. Thus current flows through the diode, and no signal is observed across the output.

During the negative half of the input cycle, the diode is reverse biased due to supply voltage but is in the forward biased state due to battery potential.

So, here output will not appear at the load until battery potential is higher than the supply voltage. As the supply voltage exceeds the battery potential, the diode stops conduction due to the reverse bias condition. Hence signal appears at the output.

- Shunt negative clipper circuits with bias

Now, let's move further and discuss the case of positive and negative biasing separately.

1. The case of positively biased circuits:

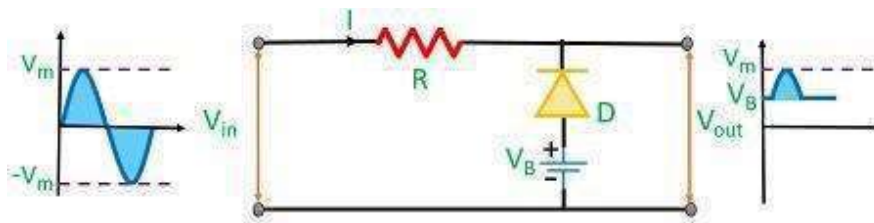

Shunt negative Clipper circuit with positive biasing

Electronics Coach

In case of positive half of the input signal, the diode gets reverse biased. However, the battery potential causes the diode to be in forward biased condition. So, until the battery potential is higher than the supply voltage, the diode conducts due to forward bias. But as the supply voltage exceeds the battery potential the conduction through diode stops. Ultimately signal appears at the output.

During the negative half of the input cycle, the diode gets forward biased because of battery potential and supply voltage. Hence, no output signal appears for the negative half of the input cycle.

## 2. The case of negatively biased circuits:

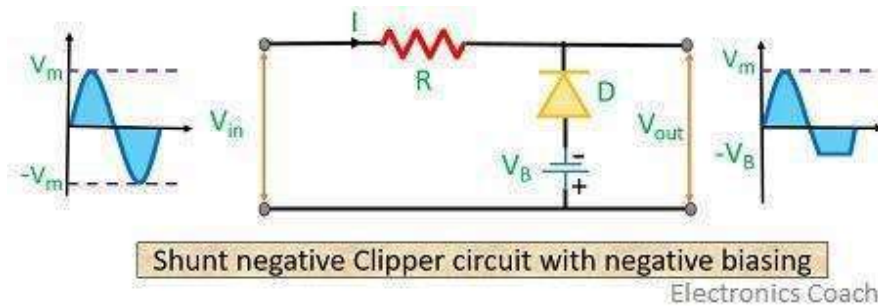

During the positive half of the input cycle, the diode gets reverse biased due to both battery potential and supply voltage. Resultantly, we have complete positive half of input signal at the output.

During the negative half of the input cycle, the diode gets forward biased due to supply voltage but is reverse biased by the battery potential. Thus, the output signal is achieved until the battery potential is higher than the supply voltage.

As the supply voltage exceeds the battery potential, the diode completely starts conduction and signal does not appear at the output.

- Dual clipper circuits

Whenever there is a need to remove a certain portion of both positive and negative half of the signal, then dual clipper circuits are used.

Let's have a look at the circuit of dual clipper shown below-

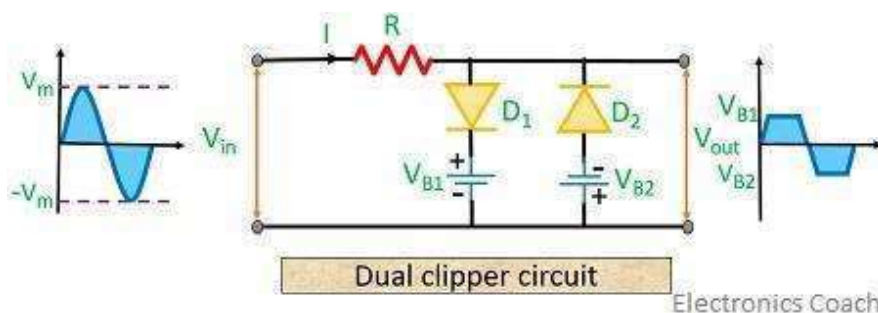

During positive half of the input cycle, diode  $D_1$  gets forward biased due to supply voltage but is in reverse bias state due to battery potential  $V_{B1}$ . At the same time, diode  $D_2$  is in reverse bias due to both supply voltage and battery potential  $V_{B2}$ .

Until battery voltage exceeds the supply voltage  $D_1$  will be in reverse-biased state and  $D_2$  is already in reverse bias condition. Hence signal is achieved at the output. But as the supply

voltage exceeds the battery potential, it causes diode  $D_1$  to be forward biased. Hence, no any further signal for the positive half is achieved in this case.

During the negative half of the input cycle, diode  $D_1$  will be reverse biased due to both supply voltage and battery potential.

Conversely, diode  $D_2$  will be forward biased by the supply voltage but is reverse biased by the battery potential  $V_{B2}$ .

Until the supply voltage is less than the battery potential,  $D_2$  will be in reverse-biased state and signal appears at the output in this condition. But, as the supply voltage exceeds the battery potential,  $D_2$  will be forward biased. Hence no any signal is obtained at the output.

### Applications of Clipper circuits

These are used in numerous applications such as in transmission, in overvoltage protection, in the modification of input waveform, in voltage limiting etc.

### **1.8 P-N DIODE CLAMPER CIRCUIT:**

Clamper circuits are the electronic circuits that shift the dc level of the AC signal. Clampers are also known as DC voltage restorers or level shifter. Clampers are basically classified as positive and negative that includes both biased and unbiased conditions individually. These circuits are used to clamp an input signal to a different dc level. It basically adds dc component to the applied input signal in order to push the signal to either the positive or negative side. Clamper circuit is a combination of a resistor along with a diode and capacitor. It sometimes also employs dc battery so as to have an additional shift in the signal level.

Clamper circuits are constructed in a similar manner as that of clipper circuits. However, clamper includes an extra charging element that is the capacitor in its circuitry. The combination of resistor and capacitor in the clamper circuit is used to maintain different dc level at the output of the clamper.

### Operating principle of Clamper circuits

As we have already discussed a clamper consist of the capacitor and a diode in shunt connection with the load.

The working of clamper circuits depends on the variation in the time constant of the capacitor. This variation is the outcome of changing the current path of the diode with the change in input signal polarity.

Here, the magnitude of the time constant is

$$\tau = RC$$

this is chosen large enough in order to assure that voltage across the capacitor does not discharge consequently at the non-conducting interval of the diode. But, such a discharge takes place only when the load resistance is very large. This permits the capacitor to take larger discharge time. Conversely, a smaller value of the capacitor is chosen so that it will charge rapidly at the time of conduction of the diode.

### Classification of Clamper Circuits-

Clampers are classified in the following groups:

#### Positive Clamper circuit

The figure below shows the circuit of a positive clamper-

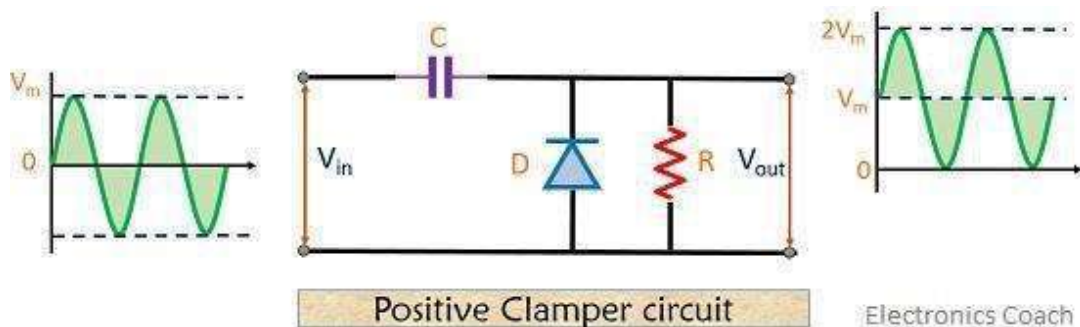

As we can see here, the diode is in parallel connection with the load. So we can say reverse biasing of the diode will provide the output at the load.

Initially, the positive half of the applied input signal reverse biases the diode but the capacitor is not still charged. So, at this period of time output will not be considered.

For, the negative half of the AC signal, the capacitor now gets fully charged up to the peak of the AC signal but with inverse polarity. This negative half forward biases the diode that results in the flow of the forward current through the diode. The next positive half then reverse biases the diode due to which signal will appear at the output.

At the beginning of the positive half of the AC signal, the diode is in the non-conducting state that results in discharging of capacitor charge. So, at the output, we will have the summation of the voltage stored across the capacitor and applied the AC input signal. This is given by

$$V_o = V_m + V_m = 2V_m$$

Here as we can in the output waveform shown above, the signal level is shifted upward or positive side. Hence it is named as positive clamper.

### Negative Clamper circuit

Let's have a look at the figure shown below of negative clamper in order to understand the detailed operation-

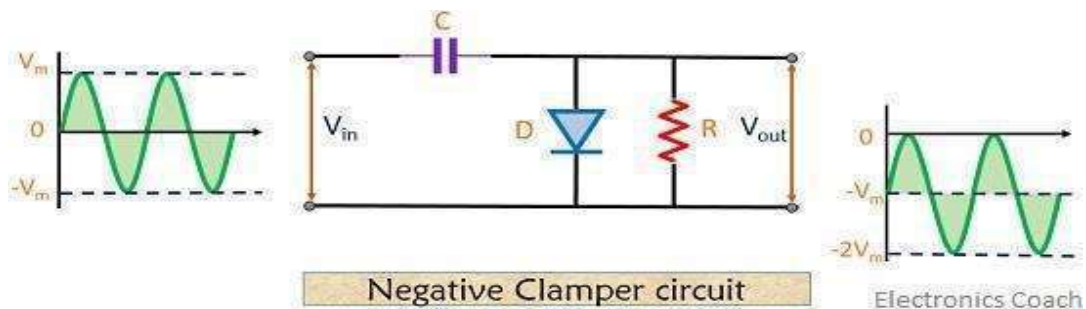

At the time when positive half of the AC input is applied, the diode comes to forward bias condition that results in no-load current at the output. However, a forward current flows through the diode that charges the capacitor to the peak of the ac signal but again with inverse polarity. The capacitor here is charged up to the forward biased condition of the diode.

When negative half of the AC signal is applied, the diode now becomes reverse biased. This allows load current to appear at the output of the circuit. Now, this non-conducting state of the diode discharges the capacitor. So, at the output, a summation of capacitor voltage along with the input voltage is achieved.

Hence at the output, we have,

$$V_o = -V_m - V_m = -2V_m$$

This results in the downward shift of the signal. Therefore, it is termed as negative clamper circuit.

### Positive clamper circuit with biasing

This is basically done to introduce an additional shift in the level of the signal. Here, the biasing provided to the circuit is of two types. It can be a positively or negatively biased circuit. So, we will discuss both the cases separately.

## 1. Case of positive biasing

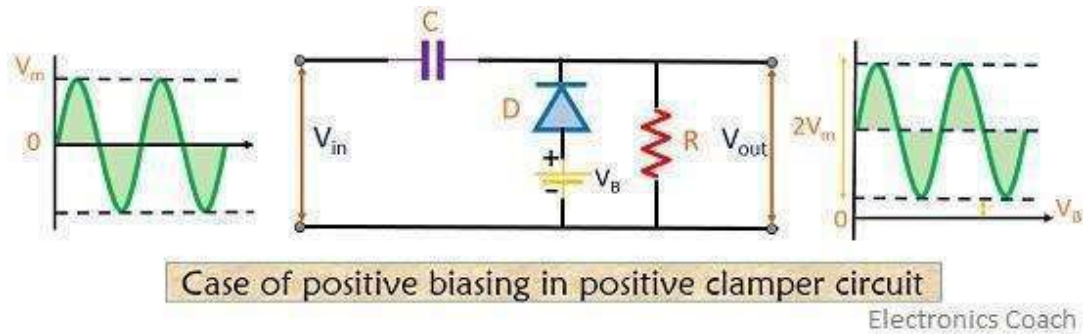

The working is almost similar to the positive unbiased case but here an additional voltage is provided so as to have an additional shift in the level of the signal.

When positive half of the input signal is applied, the diode is reverse biased due to ac input but is forward biased due to battery voltage. So, until the voltage of a battery is greater than the ac input the diode conducts. This forward current through the diode charges the capacitor but with the battery voltage. As the ac input surpasses battery voltage, the diode now gets reverse biased and hence conduction through the diode stops.

On the application of the negative half of the input signal, the diode is now forward biased due to both ac input and battery voltage and starts conducting. This charges the capacitor with voltage summation of ac input along with battery voltage. Hence such an output voltage level is achieved.

## 2. Case of negative biasing

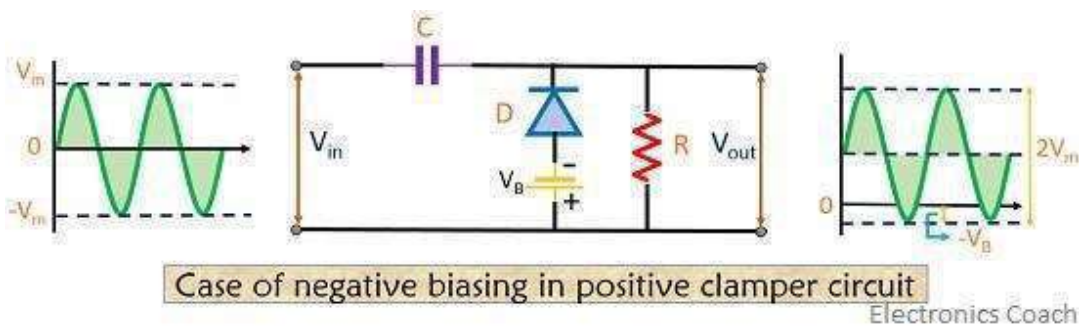

At the time of positive half of the AC signal, the diode gets reverse biased by both ac input and battery voltage. Due to this current flows through the load and combinedly maintain the voltage level.

At the time of the negative half, the diode is in the forward biased condition due to ac input but is in reverse biased condition due to battery voltage. So, the diode conducts only when

the AC input dominates the battery voltage. This charges the capacitor hence we get a shifted signal at the output.

### Negative Clamper circuit with biasing

In a similar way as previous, positive and negative biasing is provided to the negative clamper circuit. Let's now move further and discuss both the case separately.

#### 1. Case of positive biasing

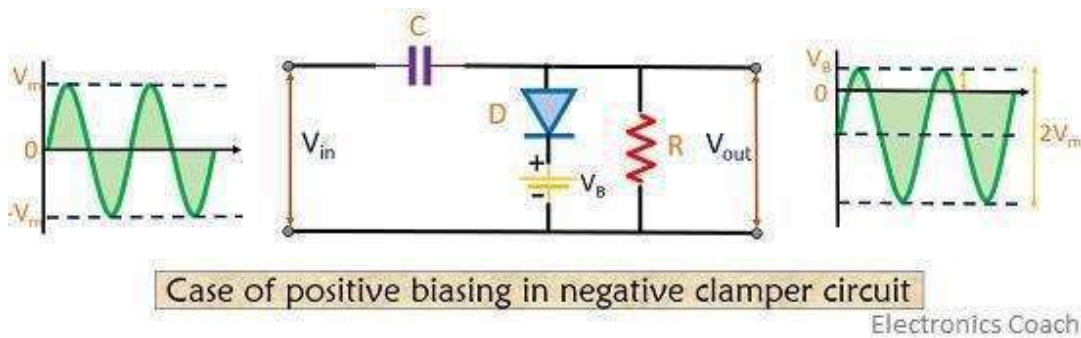

As we have already discussed that a negative clamper shifts the signal downward. However, in the case of the positively biased negative clamper, the signal is somewhat raised to a positive level due to the positively applied battery voltage. When positive half of the AC signal is applied, the diode is in the forward biased state due to ac supply but is reverse biased because of battery voltage. So, the diode conducts when ac supply surpasses battery voltage.

Moving further during the negative half, the diode is now in reverse biased state by cause of both the AC supply and battery voltage. This non-conducting state of the diode discharges the capacitor. Thus, the voltage across the capacitor appears at the output.

#### 2. Case of negative biasing

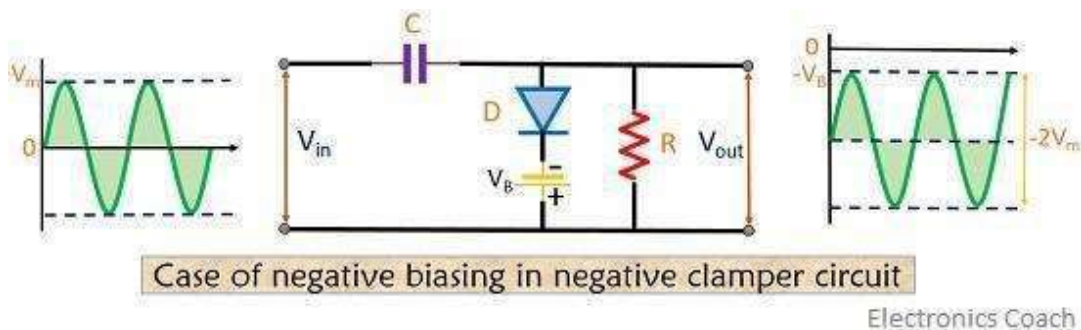

At the time of positive half of ac input, the diode gets forward biased by the cause of ac input and battery voltage. This starts conduction through the diode. Resultantly charges the capacitor.

At the time of the negative half, the diode gets reverse biased but will still conduct due to forward biased condition applied by the battery. The diode current flows until the battery voltage is more than the ac input supply. The time when ac input surpasses battery voltage, the diode gets reverse biased and the capacitor discharges. Thus the voltage across capacitor appears at the load.

### Applications of Clamper Circuits

1. Clippers are used to identify the polarity of the circuits.
2. These circuits are used as voltage doublers and help in eliminating distortions.
3. Reverse recovery time can be improved using Clippers.
4. Comparison Chart

PARAMETER	CLIPPER	CLAMPER
Definition	Clipper delimit the amplitude of the output voltage.	Clamper shifts the DC level of the output voltage.
Output Voltage	Less than the input voltage.	Multiples of input voltage.
Energy storage component	Not required	Requires (Capacitor is used as energy storage element)
Shape of Output Waveform	Shape changes (Rectangular, sinusoidal, triangular etc.)	Shape remains same as input waveform.
DC Level	Remains same	DC level get shifted
Applications	In transmitters, receivers, amplitude selector, noise limiter etc.	In voltage multiplying circuits, Sonar, Radar system etc.





## UNIT- 2: SPECIAL SEMICONDUCTOR DEVICES

### 2.1 TRANSDUCER:-

- ✓ Transducer is a device which converts one form of energy into another form i.e.; the given non-electrical energy is converted into an electrical energy.
- ✓ Common examples include microphones, loudspeakers, thermometers, position and pressure sensors and antenna.

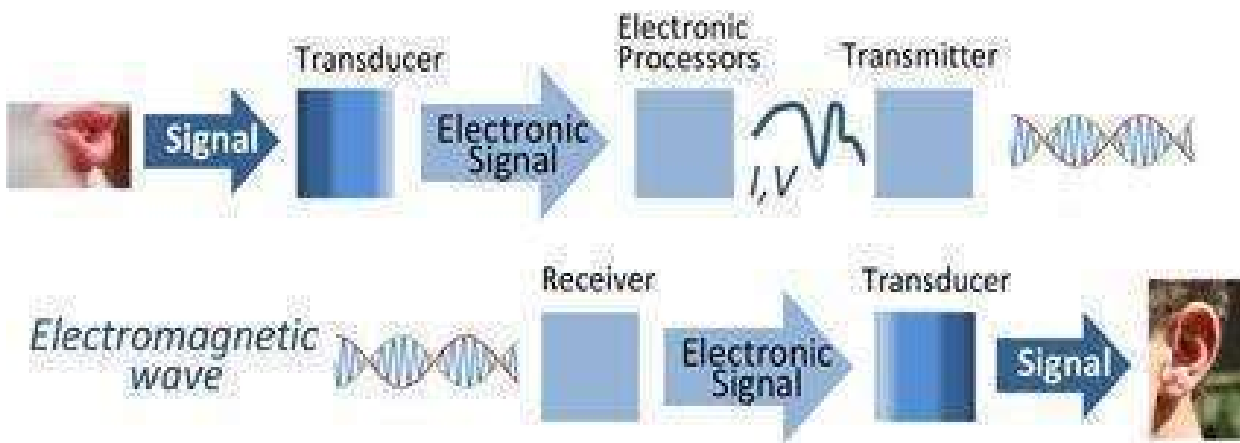

- ✓ Efficiency is an important consideration in any transducer.  
Transducer efficiency is defined as the ratio of the power output in the desired form to the total power input.
- ✓ Mathematically,  
If P represents the total power input and Q represents the power output in the desired form.

$$E = \frac{Q}{P}$$

- ✓ In percentage,

$$E (\%) = \frac{Q}{P} * 100$$

- ✓ No transducer is 100% efficient; some power is always lost in the conversion process.  
Usually this loss is dissipated in the form of heat.
- ✓ An antenna is also a transducer which converts electrical signal into electromagnetic waves and vice-versa.

- ✓ The transducer, which converts non-electrical form of energy into electrical form of energy, is known as electrical transducer.
- ✓ The block diagram of electrical transducer is shown in below figure.

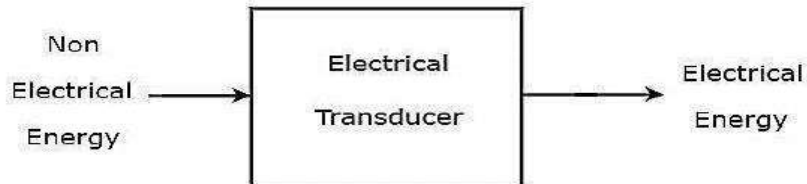

- ✓ As shown in the figure, electrical transducer will produce an output, which has electrical energy. The output of electrical transducer is equivalent to the input, which has non-electrical energy.

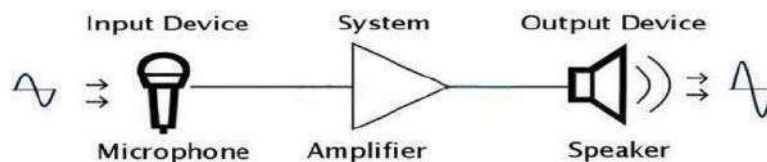

### DIFFERENT TYPES OF TRANSDUCERS:-

- ✓ First let's discuss about two main types of transducers which we use every day in our industrial life.
- ✓ They are:-
  - a) Active transducers
  - b) Passive transducers

#### a) Active transducers

- ✓ Active transducers are those which convert one form of energy into another form (electrical) without requiring any external source of power.
- ✓ These transducers draw the energy needed for their operation from the measuring system itself.
- ✓ Following are the examples of active transducers:-
  - ✚ Piezo-electric crystals  
This converts charges generated by application of force into electric potential.
  - ✚ Tachogenerator  
These are basically used to measure angular velocity
  - ✚ Thermocouple

Temperature measurement is accomplished using thermocouples.

✚ Photovoltaic cell

It converts light into electrical energy.

- ✓ The block diagram of active transducer is shown in below figure.

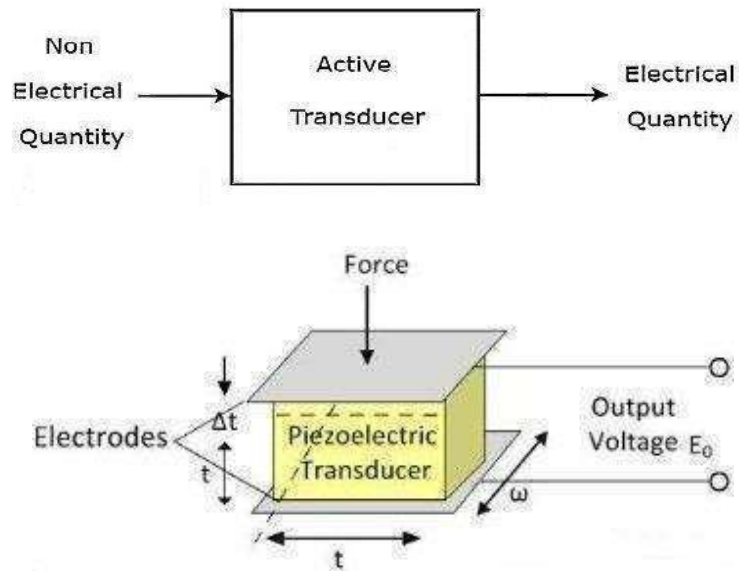

### b) Passive transducers

- ✓ Passive transducers are those transducers which convert a form of energy into another (electrical) by making use of an external source of power.
- ✓ This transducer induces variation in the parameters associated with the electrical circuits, with the variation in the applied input signal.
- ✓ Following are the examples of passive transducers.

✚ Potentiometer

It is a device that converts displacement into voltage.

✚ Thermistor

These produce voltage with change in temperature

- ✓ The block diagram of passive transducer is shown in below figure.

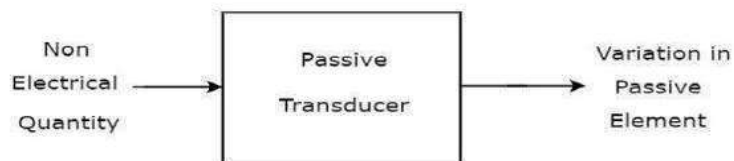

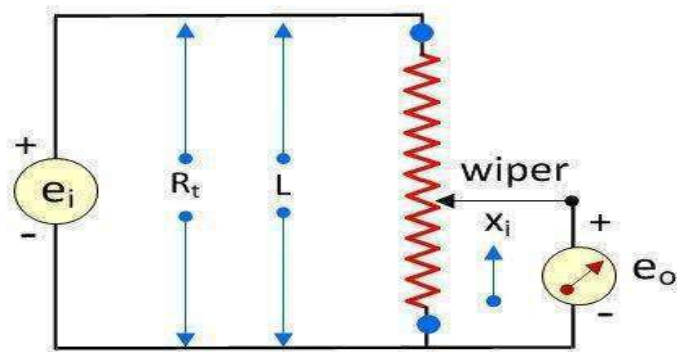

Linear Potentiometer (Pot), a passive transducer

## 2.2 THERMISTOR:-

- ✓ Thermistor, a semiconductor device is a type of passive transducer in which variation in temperature causes a corresponding change in resistance.
- ✓ Thus, variation in temperature produces an analogue voltage. As these are thermally sensitive resistors thus also termed as thermal resistors.
- ✓ The figure below shows the rod form of a Thermistor

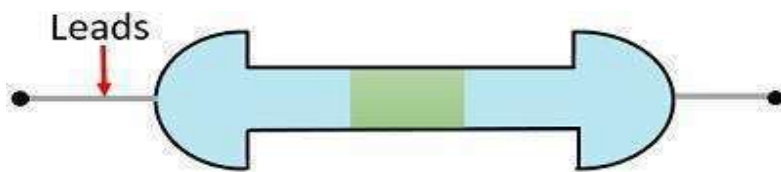

Rod form of thermistor

- ✓ Due to their temperature sensitive nature, thermistors have various applications in temperature measurement field.
- ✓ It can be a positive temperature coefficient thermistor or negative temperature coefficient thermistor depending on the variation of resistance with respect to temperature.
- ✓ An extremely non-linear characteristic is exhibited by the thermistor for resistance versus temperature curve. As it is inexpensive and highly sensitive device thus has numerous applications.

## 2.3 SENSOR:

- ✓ A sensor is a physical device that senses a physical quantity and then converts it into signals which can be read by an instrument or the user.
- ✓ The specific input could be light, heat, motion, moisture, pressure etc.
- ✓ The output is generally a signal that is converted to human-readable display at the sensor location or transmitted electronically over a network for reading or further processing.
- ✓ Sensors are sophisticated devices that are frequently used to detect and respond to electrical or optical signals.
- ✓ A Sensor converts the physical parameter (for example: temperature, blood pressure, humidity, speed, etc.) into a signal which can be measured electrically.
- ✓ Both the input and output quantities of a Sensor are Physical i.e. non-electrical in nature.

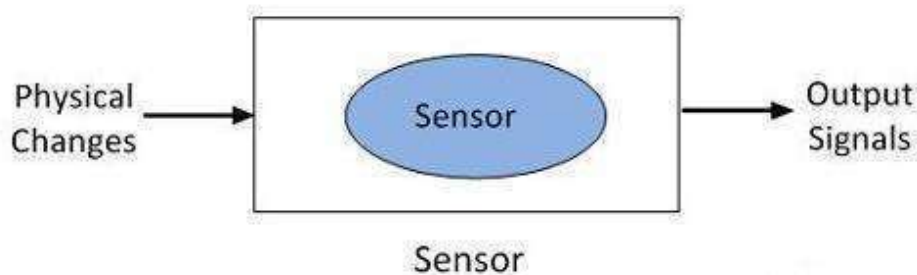

- ✓ The sensors have many applications in the electronics equipment. The few of them are explained below:-
  - The motion sensors are used in the home security system and the automation door system.
  - The photo sensor senses the infrared or ultraviolet light.
  - The accelerometer sensor used in mobile for detecting the screen rotations.

### CLASSIFICATION OF SENSORS:-

Based on the applications of sensors, their classification can be made as follows.

#### I. Displacement, Position and Proximity Sensors

1. Resistive Element or Potentiometer
2. Capacitive Elements
3. Strain Gauged Element
4. Inductive Proximity Sensors
5. Eddy Current Proximity Sensors
6. Differential Transformers
7. Optical Encoders
8. Hall Effect Sensors
9. Pneumatic Sensors
10. Proximity Switches
11. Rotary Encoders

## **II. Temperature Sensors**

1. Thermistors
2. Thermocouple
3. Bimetallic Strips
4. Resistance Temperature Detectors
5. Thermostat

## **III. Light Sensors**

1. Photo Diode
2. Phototransistor
3. Light Dependent Resistor

## **IV. Velocity and Motion**

1. Pyroelectric Sensors
2. Tachogenerator
3. Incremental encoder

## **V. Fluid Pressure**

1. Diaphragm Pressure Gauge
2. Tactile Sensor
3. Piezoelectric Sensors
4. Capsules, Bellows, Pressure Tubes

## **VI. Liquid Flow and Level**

1. Turbine Meter
2. Orifice Plate and Venturi Tube

## **VII. IR Sensor**

1. Infrared Transmitter and Receiver Pair

## **VIII. Force**

1. Strain Gauge
2. Load Cell

## **IX. Touch Sensors**

1. Resistive Touch Sensor
2. Capacitive Touch Sensors

## **X. UV Sensors**

1. Ultraviolet Light Detector
2. Photo Stability Sensors
3. UV Photo Tubes
4. Germicidal UV Detectors

## **ANALOGUE SENSORS**

- ✓ An analogue sensor produces continuously varying output signals over a range of values.
- ✓ Usually the output signal is voltage and this output signal is proportional to the measurand.
- ✓ The quantity that is being measured like speed, temperature, pressure, strain, etc. are all continuous in nature and hence they are analogue quantities.



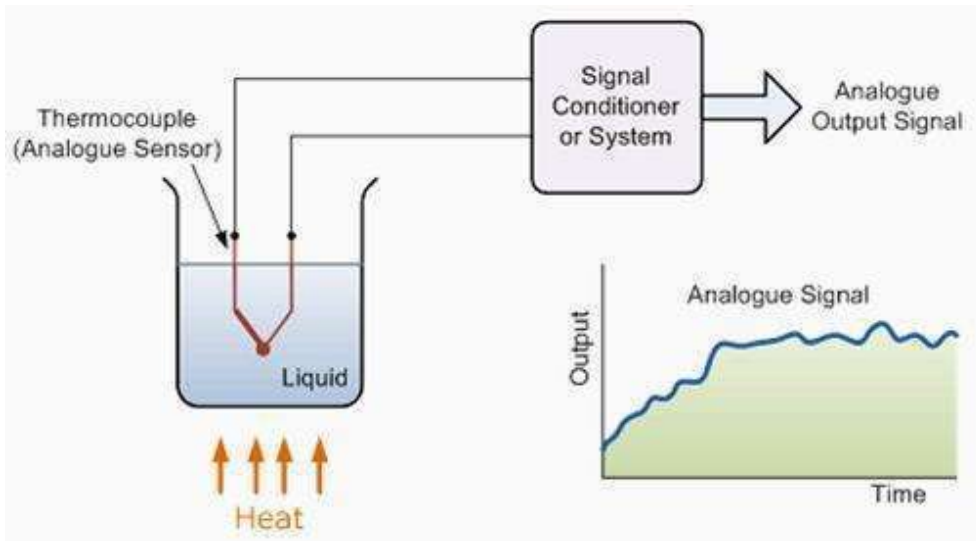

- ✓ A thermocouple or a thermometer is an analog sensor. The following setup is used to measure the temperature of the liquid in the container using a thermocouple.

#### DIGITAL SENSORS

- ✓ A digital sensor produces discrete digital signals.
- ✓ The output of a digital sensor has only two states, namely 'ON' and 'OFF'. ON is logic 1 and OFF is logic 0.
- ✓ A push button switch is the best example of a digital sensor. In this case, the switch has only two possible states: either it is ON when pushed or it is OFF when released or not pushed.

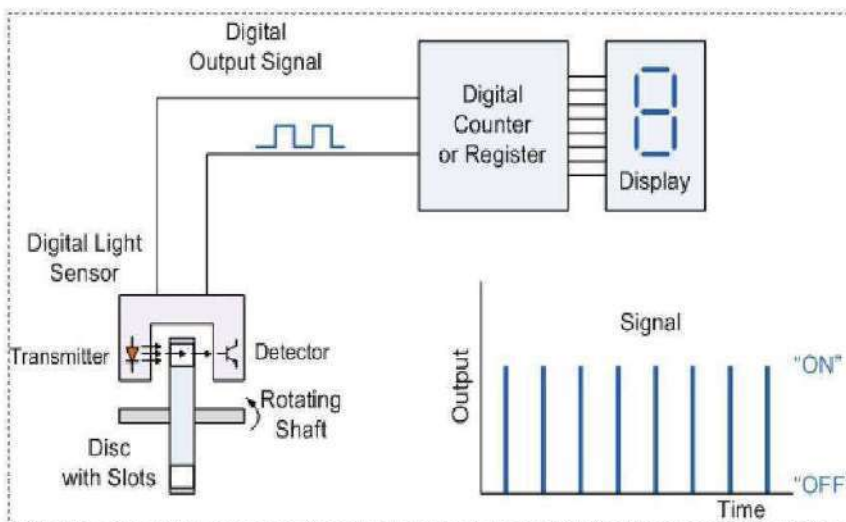

- ✓ The following setup uses a light sensor to measure the speed and produces a digital signal.
- ✓ In general, the accuracy of a digital sensor is high when compared to an analogue sensor.

- ✓ The accuracy depends on the number of bits that are used to represent the measurand.
- ✓ Higher the number of bits, the greater is the accuracy.
- ✓ Here are a few examples of the many different types of sensors:
  - a) In a mercury-based glass thermometer, the input is temperature. The liquid contained expands and contracts in response, causing the level to be higher or lower on the marked gauge, which is human-readable.
  - b) Motion sensors in various systems including home security lights, automatic doors and bathroom fixtures typically send out some type of energy, such as microwaves, ultrasonic waves or light beams and detect when the flow of energy is interrupted by something entering its path.
  - c) A photo sensor detects the presence of visible light, infrared transmission (IR), and/or ultraviolet (UV) energy.
- ✓ Both Microphone and Loudspeaker are Transducers in the sense that a microphone converts sound energy into electrical energy and a loud speaker converts electrical energy into sound energy.

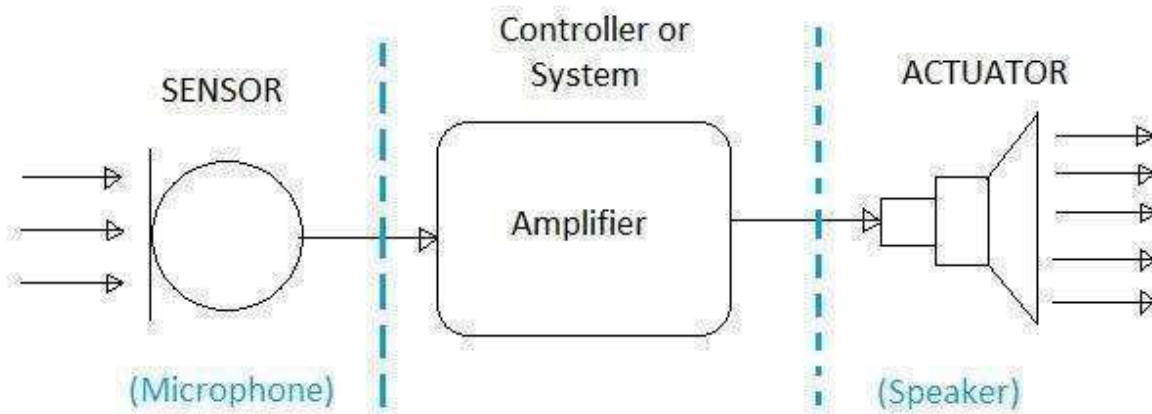

## 2.4 BARRETTTER:

- A bolometer element with a positive temperature coefficient of resistance, used to detect and measure power at radio, microwave, infrared, and optical frequencies. The temperature of the barretter increases when electromagnetic energy is absorbed. Barretters are m

ade of metal; therefore, the electrical resistance increases when the temperature increases. The resulting resistance change of the barretter is measured by using direct-current or low-frequency instruments.

- The barretter resistance is selected to absorb most of the power when the barretter is mounted as a termination in a waveguide or coaxial transmission line. A barretter can be made to detect power at optical and infrared frequencies by using a very thin metal ribbon blackened to absorb light.
- Barretters with less sensitivity and accuracy for use at radiofrequencies can be made by using low current fuses made with fine wires.
- A meter can be made to measure high frequency signal amplitudes using a barretter. The temperature and hence the resistance of a barretter can change at audio frequency rates. But the time constant of a barretter is too great for the resistance to vary at radio frequency rates.
- A radio or microwave frequency current modulated at a low frequency will cause the barretter resistance to follow the low frequency signal. If a direct current voltage is applied to the barretter while the modulated radio frequency current is also applied, the varying resistance will produce a current which follows the modulation.
- The low frequency current can be coupled to the input of an audio amplifier tuned to the modulation frequency by using an audio transformer. The output of the audio amplifier may be rectified to drive a direct current meter. The meter then indicates the relative amplitude of the radio frequency or microwave signal

## **2.5 ZENER DIODE:-**

Zener diode is basically like an ordinary PN junction diode but normally operated in reverse biased condition. But ordinary PN junction diode connected in reverse biased condition is not used as Zener diode practically. A Zener diode is a specially designed, highly doped PN junction diode.

### **Working Principle of Zener Diode**

When a PN junction diode is reverse biased, the depletion layer becomes wider. If this reverse biased voltage across the diode is increased continually, the depletion layer becomes more and more wide. At the same time, there will be a constant reverse saturation current due to minority carriers.

After certain reverse voltage across the junction, the minority carriers get sufficient kinetic energy due to the strong electric field. Free electrons with sufficient kinetic energy collide with stationary ions of the depletion layer and knock out more free electrons. These newly created free electrons also get sufficient kinetic energy due to the same electric field, and they create more free electrons by collision cumulatively. Due to this commutative phenomenon, very soon, huge free electrons get created in the depletion layer, and the entire diode will become conductive. This type of breakdown of the depletion layer is known as

avalanche breakdown, but this breakdown is not quite sharp. There is another type of breakdown in depletion layer which is sharper compared to avalanche breakdown, and this is called Zener breakdown. When a PN junction is diode is highly doped, the concentration of impurity atoms will be high in the crystal. This higher concentration of impurity atoms causes the higher concentration of ions in the depletion layer hence for same applied reverse biased voltage, the width of the depletion layer becomes thinner than that in a normally doped diode.

Due to this thinner depletion layer, voltage gradient or electric field strength across the depletion layer is quite high. If the reverse voltage is continued to increase, after a certain applied voltage, the electrons from the covalent bonds within the depletion region come out and make the depletion region conductive. This breakdown is called Zener breakdown. The voltage at which this breakdown occurs is called Zener voltage. If the applied reverse voltage across the diode is more than Zener voltage, the diode provides a conductive path to the current through it hence; there is no chance of further avalanche breakdown in it. Theoretically, Zener breakdown occurs at a lower voltage level than avalanche breakdown in a diode, especially doped for Zener breakdown. The Zener breakdown is much sharper than avalanche breakdown. The Zener voltage of the diode gets adjusted during manufacturing with the help of required and proper doping. When a Zener diode is connected across a voltage source, and the source voltage is more than Zener voltage, the voltage across a Zener diode remain fixed irrespective of the source voltage. Although at that condition current through the diode can be of any value depending on the load connected with the diode. That is why we use a Zener diode mainly for controlling voltage in different circuits.

A diode connected in reverse bias position in a circuit is shown below,

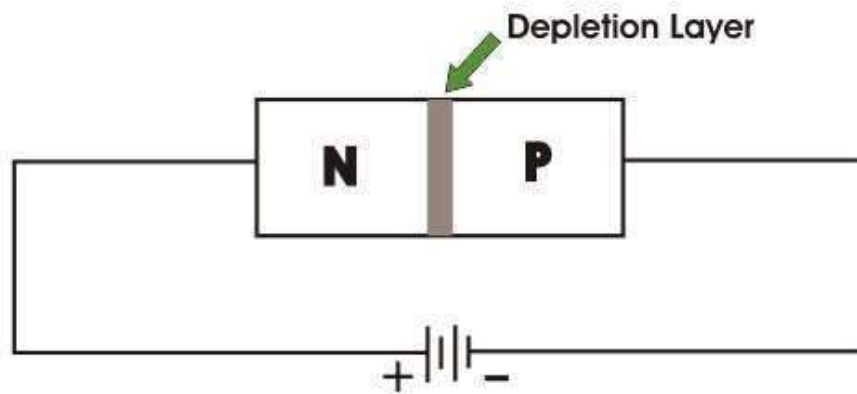

The circuit symbol of a Zener diode is also shown below

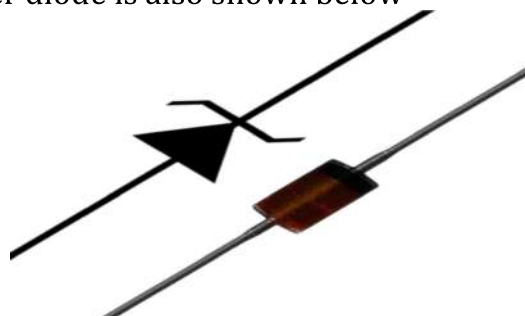

## Characteristics of a Zener Diode

The V-I characteristics of a Zener diode is given below:

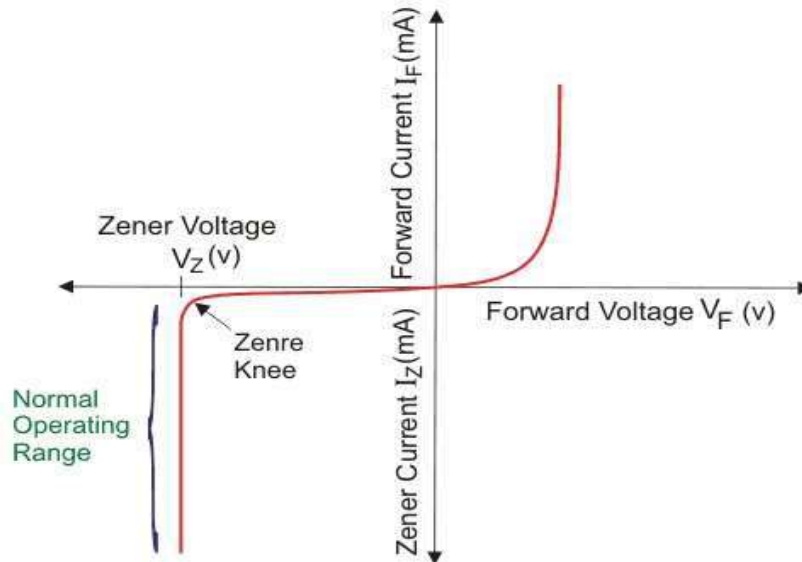

The above diagram shows the V-I characteristics of a Zener diode. When the diode is connected in forward bias, this diode acts as a normal diode but when the reverse bias voltage is greater than Zener voltage, a sharp breakdown takes place. In the V-I characteristics above  $V_z$  is the Zener voltage. It is also the knee voltage because at this point the current increases very rapidly.

## 2.6 TUNNEL DIODE:-

A tunnel diode (also known as a Esaki diode) is a type of semiconductor diode that has effectively “negative resistance” due to the quantum mechanical effect called tunneling. Tunnel diodes have a heavily doped pn junction that is about 10 nm wide. The heavy doping results in a broken band gap, where conduction band electron states on the N-side are more or less aligned with valence band hole states on the P-side.

The application of transistors in a very high in frequency range is hampered due to the transit time and other effects. Many devices use the negative conductance property of semiconductors for these high frequency applications. A tunnel diode is one of the most commonly used negative conductance devices. It is also known as Esaki diode after L. Esaki for his work on this effect.

The concentration of dopants in both p and n region is very high, at around  $10^{24} - 10^{25} \text{ m}^{-3}$ . The pn junction is also abrupt. For this reasons, the depletion layer width is very small. In the current voltage characteristics of tunnel diode, we can find a negative slope region when a forward bias is applied.

The name “tunnel diode” is due to the quantum mechanical tunneling is responsible for the phenomenon that occurs within the diode. The doping is very high so at absolute zero temperature the Fermi levels lies within the bias of the semiconductors.

### Characteristics of Tunnel Diode

When reverse bias is applied the Fermi level of the p-side becomes higher than the Fermi level of n-side. Hence, the tunneling of electrons from the balance band of p-side to the conduction band of n-side takes place. With the interments of the reverse bias the tunnel current also increases.

When forward bias is applied the Fermi level of n-side becomes higher that the Fermi level of p-side, thus the tunneling of electrons from the n-side to p-side takes place. The amount of the tunnel current is very large than the normal junction current. When the forward bias is increased, the tunnel current is increased up to certain limit.

When the band edge of n-side is the same as the Fermi level in p-side, the tunnel current is maximum with the further increment in the forward bias the tunnel current decreases and we get the desired negative conduction region. When the forward bias is raised further, normal pn junction current is obtained which is exponentially proportional to the applied voltage. The V-I characteristics of the tunnel diode is given, The negative resistance is used to achieve oscillation.

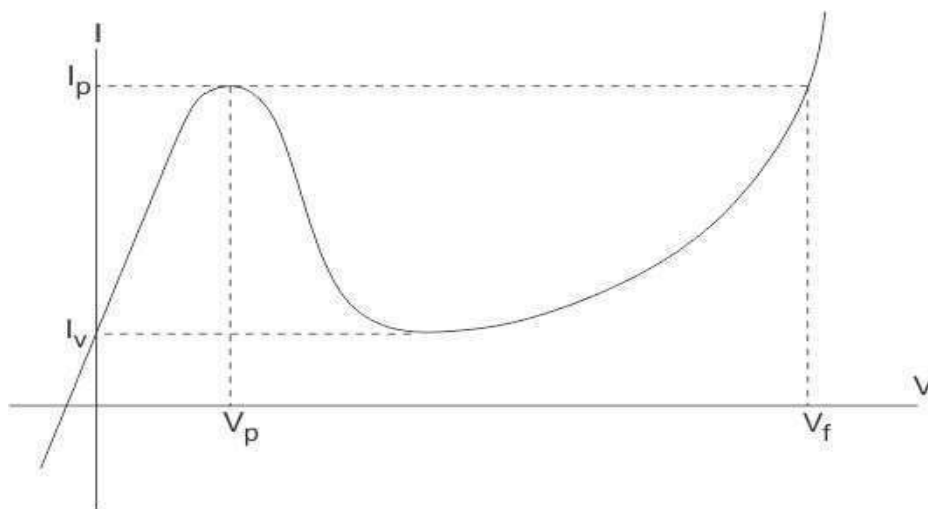

### Tunnel Diode Symbol

The symbol for a tunnel diode is shown below.

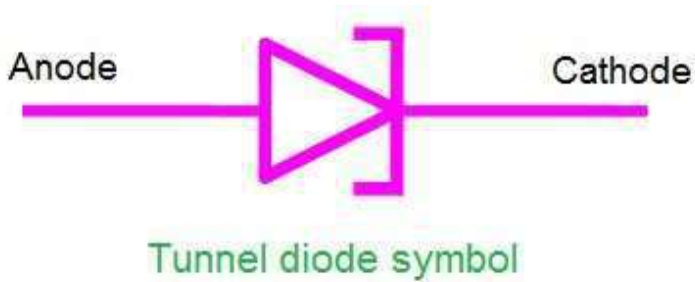

### **Tunnel Diode Applications**

Tunnel diode is a type of sc diode which is capable of very fast and in microwave frequency range. It was the quantum mechanical effect which is known as tunneling. It is ideal for fast oscillators and receivers for its negative slope characteristics. But it cannot be used in large integrated circuits – that's why it's an applications are limited.

When the voltage is first applied current starts flowing through it. The current increases with the increase of voltage. Once the voltage rises high enough suddenly the current again starts increasing and tunnel diode starts behaving like a normal diode. Because of this unusual behavior, it can be used in number of special applications started below.

#### Oscillator Circuits:

Tunnel diodes can be used as high frequency oscillators as the transition between the high electrical conductivity is very rapid. They can be used to create oscillation as high as 5Gz. Even they are capable of creativity oscillation up to 100 GHz in a appropriate digital circuits.

#### Used in Microwave Circuits:

Normal diode transistors do not perform well in microwave operation. So, for microwave generators and amplifiers tunnel diode are used. In microwave waves and satellite communication equipment they were used widely, but lately their usage is decreasing rapidly, as transistors which operate in this frequency range are becoming available.

Tunnel diodes are resistant to the effects of magnetic fields, high temperature and radioactivity. That's why these can be used in modern military equipment. These are used in nuclear magnetic resource machine also. But the most important field of its use satellite communication equipment.

## 2.7 PIN DIODE:

A Pin diode is a special type of diode that contains an undoped intrinsic semiconductor between the p-type semiconductor and n-type semiconductor regions. It differs from a normal diode in the sense that it has an extra layer in between the p and the n junctions. By an intrinsic layer, we mean a pure crystal of silicon or germanium without any doping in it. This layer does not conduct electric current well. The p-type and n-type layer is heavily doped as they are used for ohmic contacts.

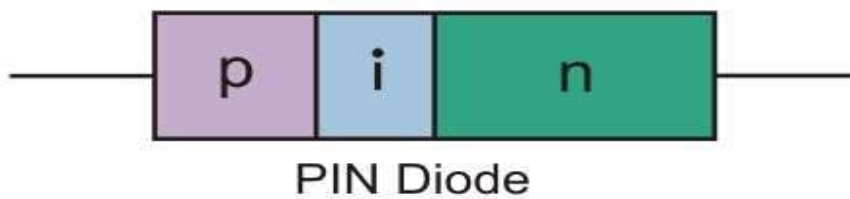

It's like having a p region, followed by an intrinsic region and then an N region, thus making it a PIN diode and hence derived the name from the same.

The symbol of pin diode is as follows:



### Construction of a PIN Diode

A pin diode has an intrinsic undoped layer (having high resistivity) sandwiched between a PN junction, we will now look at the construction of the diode in detail. Pin diode can be constructed in two different structures: Mesa structure and planar structure. In mesa structure, layers which are already doped are grown onto the substrate (intrinsic layer). The amount of doping and thickness of the layer can be controlled as per the requirement. In a planar structure, an epitaxial layer is grown onto the substrate material and the p+ region is created either by ion implantation or diffusion.

### Working of the PIN Diode

Although the working of a pin diode is similar to a regular diode, there are some differences due to the additional intrinsic layer. Pin diode is an inferior rectifier but is widely suitable for switches, attenuators etc.



## Forward biased operation of PIN Diode

When the PIN diode is subjected to forward bias, the depletion region at the p-n junction reduces. With the reduction of the depletion region, current starts flowing through the diode. The PIN diode acts as a variable resistance when operated in forward bias. A high electric field is developed across the junction and this speeds up the transport of charge carriers from the P region to the N region. This helps in faster operation and therefore pin diode is used for high-frequency applications.

The width of the depletion region increases, when the pin diode operates in reverse biased condition. At a certain reverse bias voltage, the entire intrinsic layer will be swept out of charge carriers. This voltage is called the swept in voltage. The value is  $-2v$ . It is used for switching purposes while in reverse bias.

## Characteristics of PIN Diode

At a lower level of reverse bias, the depletion layer becomes fully depleted. The capacitance of the pin diode becomes independent of the level of bias once the depletion layer is fully depleted. This is because there is very little net charge in the intrinsic layer. The leakage of RF signal is lower than other diodes because the level of capacitance is typically lower.

In forward bias, the diode behaves as a resistor than a non-linear device and produces no rectification or distortion. The value of the resistance depends on the bias voltage. Pin diode is used as RF switch or variable resistor as they produce fewer distortions than a normal diode.

## Application of PIN Diode

Pin diodes are used for a number of applications. Some of the important usages of these types of diodes are:

- **RF switch:** As discussed above, a pin diode can be used as an RF switch. Due to the intrinsic layer between the PN junctions, the level of capacitance decreases. As a consequence, the level of isolation is increased when the diode is reversed bias. This makes it an ideal RF switch.
- **High Voltage Rectifier:** Due to the intrinsic layer, the distance between the p-n junctions is increased and thus allowing higher voltage tolerance between the junctions.
- **Photo detector:** The conversion of light into electric current depends on the depletion region of the photodiode. In a pin diode, the depletion region is increased by adding an intrinsic layer between the p-n junctions. Due to the increase in the depletion region, the volume of conversion is increased and the efficiency of the photodiode too. Hence pin diode is used as photodiodes.



## UNIT-3: RECTIFIER CIRCUITS & FILTERS

### 3.1 RECTIFIERS AND CLASSIFICATION OF RECTIFIER:-

Rectifier is an electronic device which converts the alternating current to unidirectional current, in other words rectifier converts the AC voltage to DC voltage. We use rectifier in almost all the electronic devices mostly in the power supply section to convert the main voltage into DC voltage. Every electronic device will work on the DC voltage supply only.

Rectifiers are classified according to the period of conduction.

They are

1. Half Wave Rectifier
2. Full Wave Rectifier

### 3.2 ANALYSIS OF HALF WAVE, FULL WAVE CENTRE TAPPED AND BRIDGE RECTIFIERS:

#### Half Wave Rectifier:

The half wave rectifier is a type of rectifier that rectifies only half cycle of the waveform. This article describes the half wave rectifier circuit working. The half rectifier consist a step down transformer, a diode connected to the transformer and a load resistance connected to the cathode end of the diode. The circuit diagram of half wave rectifier is shown below:

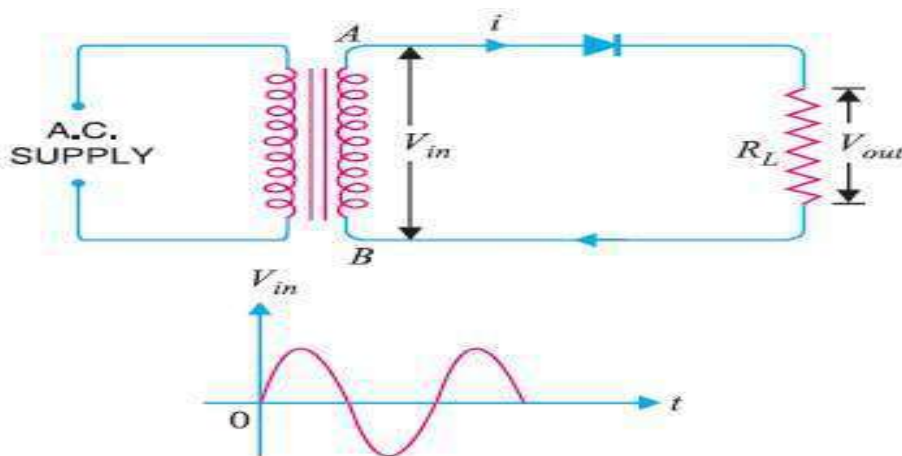

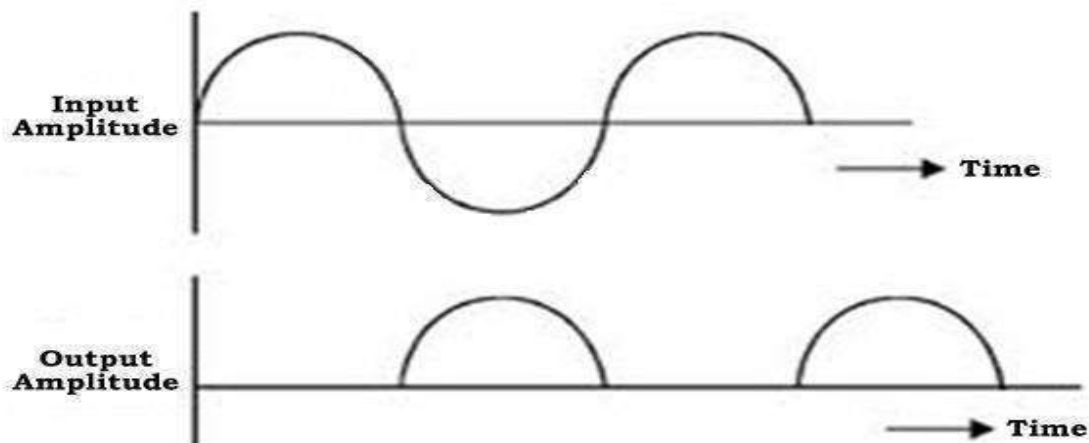

The main supply voltage is given to the transformer which will increase or decrease the voltage and give to the diode. In most of the cases we will decrease the supply voltage by using the step down transformer here also the output of the step down transformer will be in AC. This decreased AC voltage is given to the diode which is connected serial to the secondary winding of the transformer, diode is electronic component which will allow only the forward bias current and will not allow the reverse bias current. From the diode we will get the pulsating DC and give to the load resistance  $R_L$ .

### **Working of Half Wave Rectifier:**

The input given to the rectifier will have both positive and negative cycles. The half rectifier will allow only the positive half cycles and omit the negative half cycles. So first we will see how half wave rectifier works in the positive half cycles.

#### **Positive Half Cycle:**

- In the positive half cycles when the input AC power is given to the primary winding of the step down transformer, we will get the decreased voltage at the secondary winding which is given to the diode.
- The diode will allow current flowing in clock wise direction from anode to cathode in the forward bias (diode conduction will take place in forward bias) which will generate only the positive half cycle of the AC.
- The diode will eliminate the variations in the supply and give the pulsating DC voltage to the load resistance  $R_L$ . We can get the pulsating DC at the Load resistance.

Negative Half Cycle:

- In the negative half cycle the current will flow in the anti-clockwise direction and the diode will go in to the reverse bias. In the reverse bias the diode will not conduct so, no current is flown from anode to cathode, and we cannot get any power at the load resistance.
- Only small amount of reverse current is flown from the diode but this current is almost negligible. And voltage across the load resistance is also zero.

### Characteristics of Half Wave Rectifier:

There are some characteristics to the half wave rectifier they are

**1. Efficiency:** The efficiency is defined as the ratio of input AC to the output DC.

$$\text{Efficiency, } \eta = P_{dc} / P_{ac}$$

$$\text{DC power delivered to the load, } P_{dc} = I_{dc}^2 R_L = (I_{max}/\pi)^2 R_L$$

AC power input to the transformer,  $P_{ac}$  = Power dissipated in junction of diode + Power dissipated in load resistance  $R_L$

$$= I_{rms}^2 R_F + I_{rms}^2 R_L = \{I_{MAX}^2/4\}[R_F + R_L]$$

$$\text{Rectification Efficiency, } \eta = P_{dc} / P_{ac} = \{4/\pi^2\}[R_L / (R_F + R_L)] = 0.406 / \{1 + R_F/R_L\}$$

If  $R_F$  is neglected, the efficiency of half wave rectifier is 40.6%.

**2. Ripple factor:** It is defined as the amount of AC content in the output DC. It is nothing but amount of AC noise in the output DC. Less the ripple factor, performance of the rectifier is more. The ripple factor of half wave rectifier is about 1.21. It can be calculated as follows:

The effective value of the load current  $I$  is given as sum of the rms values of harmonic currents  $I_1, I_2, I_3, I_4$  and DC current  $I_{dc}$ .

$$I^2 = I_{dc}^2 + I_1^2 + I_2^2 + I_4^2 = I_{dc}^2 + I_{ac}^2$$

Ripple factor, is given as  $\gamma = I_{ac} / I_{dc} = (I^2 - I_{dc}^2) / I_{dc} = \{(I_{rms} / I_{dc})^2 - 1\} = K_f^2 - 1$

Where  $K_f$  is the form factor of the input voltage. Form factor is given as

$$K_f = I_{rms} / I_{avg} = (I_{max}/2) / (I_{max}/\pi) = \pi/2 = 1.57$$

$$\text{So, ripple factor, } \gamma = (1.57^2 - 1) = 1.21$$

**3. Peak Inverse Voltage:** It is defined as the maximum voltage that a diode can withstand in reverse bias. During the reverse bias as the diode does not conduct total voltage drops across the diode. Thus peak inverse voltage is equal to the input voltage  $V_s$ .

**4. Transformer Utilization Factor (TUF):** The TUF is defined as the ratio of DC power delivered to the load and the AC rating of the transformer secondary. Half wave rectifier has around 0.287 and full wave rectifier has around 0.693.

$$\begin{aligned} \checkmark \text{ TUF} &= \frac{P_{dc}}{P_{ac}} \\ &= \frac{(\frac{I_m}{\pi})^2 R_L}{\frac{V_m I_m}{2\sqrt{2}}} \\ &= 0.287 \end{aligned}$$

## 5. Voltage regulation

The variation of d.c output voltage as function of d.c load current is called regulation.

$$\text{V.R in \%} = \frac{V_{NL} - V_{FL}}{V_{FL}} * 100$$

Where,  $V_{NL}$  = DC voltage across load resistance when minimum current flows through it.

$V_{FL}$  = DC voltage across load resistance when maximum current flows through it.

## 6. Form factor

It is the ratio of the rms value to the average value.

$$\text{Form factor} = \frac{\text{Rms value}}{\text{Average value}} = \frac{I_m/2}{I_m/\pi} = 1.57$$

## 7. Output DC Voltage

The output voltage ( $V_{DC}$ ) across the load resistor is denoted by:

$$V_{DC} = \frac{V_{Smax}}{\pi}, \text{ where } V_{Smax} = \text{maximum amplitude of secondary voltage}$$

## 8. RMS value of Half Wave Rectifier

To derive the RMS value of half wave rectifier, we need to calculate the current across the load. If the instantaneous load current is equal to  $i_L = I_m \sin \omega t$ , then the average of load current ( $I_{DC}$ ) is equal to:

$$I_{dc} = \frac{1}{2\pi} \int_0^{\pi} I_m \sin \omega t = \frac{I_m}{\pi}$$

Where  $I_m$  is equal to the peak instantaneous current across the load ( $I_{max}$ ). Hence the output DC current ( $I_{DC}$ ) obtained across the load is:

$$I_{DC} = \frac{I_{max}}{\pi}, \text{ where } I_{max} = \text{maximum amplitude of dc current}$$

For a half-wave rectifier, the RMS load current ( $I_{rms}$ ) is equal to the average current ( $I_{DC}$ ) multiple by  $\pi/2$ . Hence the RMS value of the load current ( $I_{rms}$ ) for a half wave rectifier is:

$$I_{rms} = \frac{I_m}{2}$$

Where  $I_m = I_{max}$  which is equal to the peak instantaneous current across the load.

Half wave rectifier is mainly used in the low power circuits. It has very low performance when it is compared with the other rectifiers.

## FULL WAVE RECTIFIER:-

Full wave rectifier rectifies the full cycle in the waveform i.e. it rectifies both the positive and negative cycles in the waveform. This Full wave rectifier has an advantage over the half wave i.e. it has average output higher than that of half wave rectifier. The number of AC components in the output is less than that of the input.

The full wave rectifier can be further divided mainly into following types.

1. Center Tapped Full Wave Rectifier
2. Full Wave Bridge Rectifier

## Center Tapped Full Wave Rectifier

Center tap is the contact made at the middle of the winding of the transformer.

In the center tapped full wave rectifier two diodes were used. These are connected to the center tapped secondary winding of the transformer. Above circuit diagram shows the center tapped full wave rectifier. It has two diodes. The positive terminal of two diodes is connected to the two ends of the transformer. Center tap divides the total secondary voltage into equal parts.

Center Tapped Full Wave Rectifier Working:

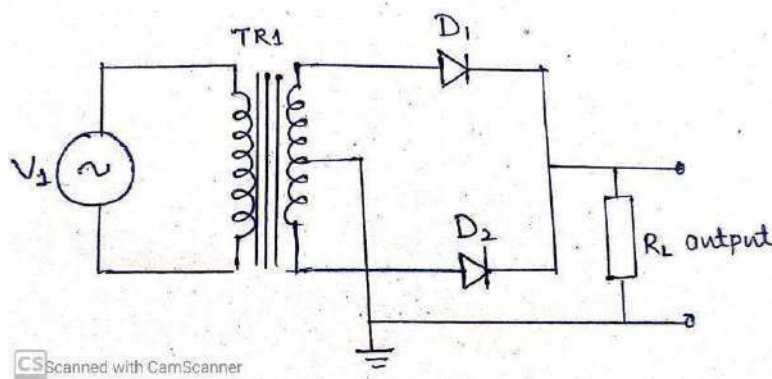

The primary winding of the center tap transformer is applied with the AC voltage. Thus the two diodes connected to the secondary of the transformer conducts alternatively. For the positive half cycle of the input diode D1 is connected to the positive terminal and D2 is connected to the negative terminal. Thus diode D1 is in forward bias and the diode D2 is reverse biased. Only diode D1 starts conducting and thus current flows from diode and it appears across the load  $R_L$ . So positive cycle of the input appears at the load.

During the negative half cycle the diode D2 is applied with the positive cycle. D2 starts conducting as it is in forward bias. The diode D1 is in reverse bias and this does not conduct. Thus current flows from diode D2 and hence negative cycle is also rectified, it appears at the load resistor  $R_L$ .

By comparing the current flow through load resistance in the positive and negative half cycles, it can be concluded that the direction of the current flow is same. Thus the frequency of rectified output voltage is two times the input frequency. The output that is rectified is not pure, it consists of a DC component and a lot of AC components of very low amplitudes.



### **Peak Inverse Voltage (PIV) of Centre Tap Full Wave Rectifier:**

PIV is defined as the maximum possible voltage across a diode during its reverse bias. During the first half that is positive half of the input, the diode D1 is forward bias and thus conducts providing no resistance at all. Thus, the total voltage  $V_s$  appears in the upper-half of the ac supply, provided to the load resistance  $R$ . Similarly, in the case of diode D2 for the lower half of the transformer total secondary voltage developed appears at the load. The amount of voltage that drops across the two diodes in reverse bias is given as

$$\text{PIV of D2} = V_m + V_m = 2V_m$$

$$\text{PIV of D1} = 2V_m$$

$V_m$  is the voltage developed across upper and lower halves.

### **Peak Current**

The peak current is the instantaneous value of the voltage applied to the rectifier. It can be written as

$$V_s = V_{sm} \sin \omega t$$

Let us assume that the diode has a forward resistance of  $R_F$  ohms and a reverse resistance is equal to infinity, thus current flowing through the load resistance  $R_L$  is given as

$$I_m = V_{sm} / (R_F + R_L)$$

### **Transformer Utilization Factor:**

This can be calculated by considering primary and secondary windings separately. Its value is 0.693. This can be used to determine transformer secondary rating.

Output Current:

Since the current is same through the load resistance  $R_L$  in the two halves of the ac cycle, magnitude of dc current  $I_{dc}$ , which is equal to the average value of ac current,

can be obtained by integrating the current  $I_1$  between 0 and  $\pi$  or current  $I_2$  between  $\pi$  and  $2\pi$ .

$$I_{dc} = \frac{1}{\pi} \int_0^{\pi} I_1 d(\omega t) = \frac{1}{\pi} \int_0^{\pi} I_{max} \sin \omega t d(\omega t) = \frac{2I_m}{\pi}$$

DC output voltage:

Average value or dc value of voltage across the load is given by

$$I_{dc} = \frac{1}{\pi} \int_0^{\pi} I_1 d(\omega t) = \frac{1}{\pi} \int_0^{\pi} I_{max} \sin \omega t d(\omega t) = \frac{2I_m}{\pi}$$

Root Mean Square (RMS) value of current:

RMS value of current flowing through the load resistance is given as

$$I_{RMS}^2 = \frac{1}{\pi} \int_0^{\pi} I_1^2 d(\omega t) = \frac{I_m^2}{2}$$

Or

$$I_{rms} = \frac{I_m}{\sqrt{2}}$$

Root Mean Square (RMS) Value of output voltage:

RMS value of voltage across the load is given by:

$$V_{load,rms} = I_{rms} * R_{load}$$

Rectification efficiency:

$$P_{dc} = I_{dc}^2 R_L = \left(\frac{2I_m}{\pi}\right)^2 R_L = \left(\frac{4}{\pi^2}\right) I_m^2 R_L$$

As power input to the transformer = power dissipated at the diode + power dissipated at the in load resistance  $R_L$ .

$$I_{rms}^2 R_F + I_{rms}^2 R_{load} = \left\{ \frac{I_m^2}{2} \right\} [R_F + R_{load}]$$

$$\text{Rectification efficiency } \eta = \frac{P_{dc}}{P_{ac}} = \frac{\left(\frac{4}{\pi^2}\right) I_m^2 R_L}{\left\{ \frac{I_m^2}{2} \right\} [R_F + R_{load}]}$$

Ripple factor:

Form factor  $K_f$  of the rectified output voltage of a full wave rectifier is given as

$$K_f = I_{rms}/I_{avg} = \frac{I_m/\sqrt{2}}{(2I_m/\pi)} = 1.11$$

Regulation:

The dc output voltage is given by

$$\begin{aligned} V_{dc} &= I_{dc}R_L = 2/(\pi I_m R_L) \\ &= 2V_{sm}R_L/\pi(R_F + R_L) \\ &= (2V_{sm}/\pi) - (I_{dc}R_F) \end{aligned}$$

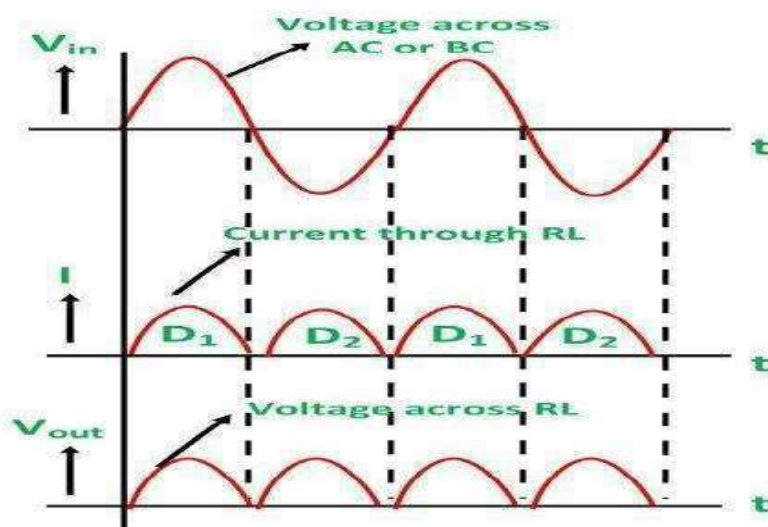

#### Advantages:-

- ✓ Output is obtained for both cycles of input ac voltages.
- ✓ Efficiency is higher than that of half wave rectifier.

#### Disadvantages:-

- ✓ Locating center tap on the secondary winding is difficult.
- ✓ The diodes used have high PIV.
- ✓ The d.c output is small as each diode utilizes only one half of the transformer secondary voltage.

## FULL WAVE BRIDGE RECTIFIER

Bridge is a type of electrical circuit. Bridge rectifier is a type of rectifier in which diodes were arranged in the form of a bridge. This provides full wave rectification and is of low cost. So it is used in many applications.

### Bridge Rectifier:

In bridge rectifier four diodes are used. These are connected as shown in the circuit diagram. The four diodes are connected in the form of a bridge to the transformer and the load as shown.

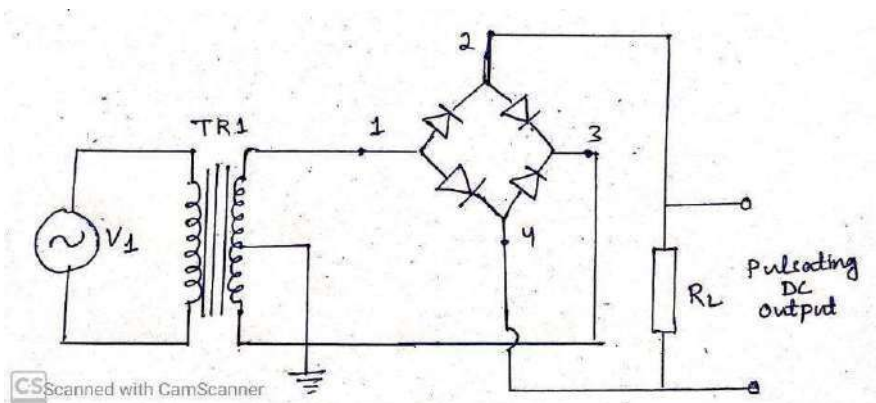

### Working of Bridge Rectifier:

The working of a bridge rectifier is simple. The circuit diagram of bridge rectifier is given above. The secondary winding of the transformer is connected to the two diametrically opposite points of the bridge at points 1 and 3. Assume that a load is connected at the output. The load  $R_{Load}$  is connected to bridge through points 2 and 4.

During first half cycle of the AC input, the upper portion of the transformer secondary winding is positive with respect to the lower portion. Thus during the first half cycle diodes  $D_1$  and  $D_4$  are forward biased. Current flows through path 1-2, enter into the load  $R_L$ . It returns back flowing through path 4-3. During this half input cycle, the diodes  $D_2$  and  $D_3$  are reverse biased. Hence there is no current flow through the path 2-3 and 1-4.

During the next cycle lower portion of the transformer is positive with respect to the upper portion. Hence during this cycle diodes D2 and D3 are forward biased. Current flows through the path 3-2 and flows back through the path 4-1. The diodes D1 and D4 are reverse biased. So there is no current flow through the path 1-2 and 3-4. Thus negative cycle is rectified and it appears across the load.

Peak Inverse Voltage (PIV) of a bridge rectifier = Maximum of Secondary Voltage

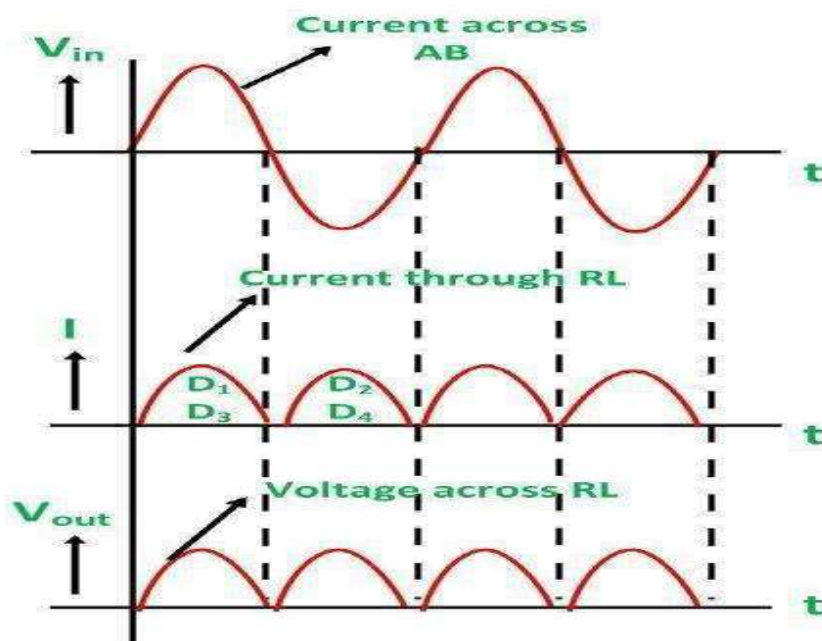

**Advantages:-**

- ✓ PIV is one half that of centre tap circuit.
- ✓ Output is twice that of centre tap circuit.
- ✓ Need for centre tapped transformer is eliminated.

**Disadvantages:-**

- ✓ Requires 4 diodes which increase the cost.

**EFFICIENCY-**

Let  $v=V_m \sin\theta$  be the ac voltage to be rectified.

$r_f$ = diode resistance

$R_L$ =load resistance

$$i = \frac{V_m \sin \theta}{r_f + R_L}$$

### D.C current:-

$$\begin{aligned} I_{dc} = I_{avg} &= 2 * \frac{1}{2\pi} \int_0^\pi i * d\theta \\ &= \frac{1}{\pi} \int_0^\pi \frac{V_m \sin \theta}{r_f + R_L} * d\theta \\ &= \frac{V_m}{\pi(r_f + R_L)} \int_0^\pi \sin \theta * d\theta \\ I_{dc} &= \frac{V_m}{\pi(r_f + R_L)} [-\cos \theta]_0^\pi \\ &= \frac{V_m}{\pi(r_f + R_L)} [-\cos \pi + \cos 0] \\ &= \frac{V_m}{\pi(r_f + R_L)} [-(-1) + 1] \\ &= \frac{V_m}{\pi(r_f + R_L)} * 2 \\ &= \frac{2I_m}{\pi} \end{aligned}$$

### AC current:-

$$\begin{aligned} I_{ac}^2 &= \frac{1}{\pi} \int_0^\pi (I_m \sin \theta)^2 * d\theta \\ &= \frac{1}{\pi} \int_0^\pi I_m^2 * \sin^2 \theta * d\theta \\ &= \frac{I_m^2}{2\pi} \int_0^\pi (1 - \cos 2\theta) * d\theta \\ I_{rms}^2 &= \frac{I_m^2}{2\pi} * \pi \\ I_{rms} &= \frac{I_m}{\sqrt{2}} \end{aligned}$$

$$\begin{aligned} P_{ac} &= I_{rms}^2 (r_f + R_L) \\ &= \left(\frac{I_m}{\sqrt{2}}\right)^2 (r_f + R_L) \end{aligned}$$

$$\begin{aligned}\text{Rectifier efficiency } (\eta) &= \frac{P_{dc}}{P_{ac}} \\ &= \frac{\left(\frac{2I_m}{\pi}\right)2R_L}{\left(\frac{I_m^2}{2}\right)2(r_f+R_L)} \\ &= \frac{8}{\pi^2 \left(\frac{r_f}{R_L} + 1\right)}\end{aligned}$$

As  $\frac{r_f}{R_L}$  is a very small value, so it can be neglected from the denominator.

Thus, we get,  $\eta = \frac{8}{\pi^2}$

$$\eta \text{ (in \% age)} = \frac{8}{\pi^2} * 100 = 81.2\%$$

### **RIPPLE FATOR:-**

$$\begin{aligned}\text{Ripple factor} &= \sqrt{\left(\frac{I_{rms}}{I_{dc}}\right)^2 - 1} \\ &= \sqrt{\left(\frac{I_m/\sqrt{2}}{2I_m/\pi}\right)^2 - 1} = 0.48\end{aligned}$$

### **FORM FACTOR:-**

✓ It is the ratio of the rms value to the average value.

$$\text{Form factor} = \frac{\text{RMS value}}{\text{Average value}} = \frac{I_m/\sqrt{2}}{2I_m/\pi} = 1.11$$

### **PEAK INVERSE VOLTAGE:-**

✓ It is the maximum reverse voltage that a diode can withstand without destroying the junction.

$$\text{PIV} = 2V_m$$

### **TRANSFORMER UTILIZATION FACTOR (TUF):-**

✓ TUF in a circuit should be as high as possible.

$$P_{ac} = V_{rms} I_{rms}$$

$$= \frac{V_m I_m}{2}$$

$$P_{dc} = I_{dc}^2 \cdot R_L$$

$$= \left( \frac{2I_m}{\pi} \right)^2 \cdot R_L$$

$$\begin{aligned} \checkmark \text{ TUF} &= \frac{P_{dc}}{P_{ac}} \\ &= \frac{\left( \frac{2I_m}{\pi} \right)^2 R_L}{\frac{V_m I_m}{2}} \\ &= \frac{8}{\pi^2} \\ &= 0.811 \end{aligned}$$

### Bridge Rectifier Circuit Analysis:

In the bridge rectifier circuit, among four diodes two diodes conduct during one half cycles. Thus forward resistance becomes double that is  $2R_F$ .

### Peak Current:

Instantaneous value of the applied voltage to the rectifier is given as

$$V_s = V_{smax} \sin \omega t$$

Let us assume that the diode has a forward resistance of  $R_F$  ohms and a reverse resistance is equal to infinity, thus current flowing through the load  $R_L$  is given as

- $i_1 = I_{max} \sin \omega t$  and  $i_2 = 0$  during the first half cycle and
- $i_1 = 0$  and  $i_2 = I_{max} \sin \omega t$  during second half cycle

The total current flowing through the load resistance  $R_L$ , the sum of currents  $i_1$  and  $i_2$  is given as

$$i = i_1 + i_2 = I_{max} \sin \omega t \text{ for the complete cycle.}$$



The peak value of current flowing through the load  $R_L$  is given as

$$I_{\max} = V_{\max} / (2R_F + R_L)$$

### Bridge Rectifier Applications:

- Because of their low cost compared to center tapped they are widely used in power supply circuit.
- This can be used to detect the amplitude of modulated radio signal.
- Bridge rectifiers can be used to supply polarized voltage in welding.

### 3.3 FILTER:-

A filter is a device which removes the ac component of rectifier output but allows the dc component to reach the load. A filter should be connected between the rectifier output & the load. A filter circuit is a combination of inductor & capacitor.

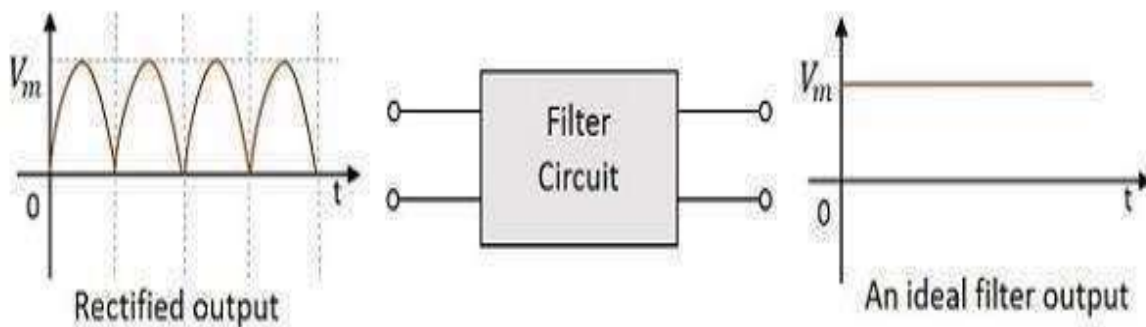

- ✓ Filter circuits are classified into four types
1. Inductor filter
  2. Capacitor filter
  3. Choke input filter
  4. Capacitor input filter or  $\pi$  filter

### 3.3.1 INDUCTOR FILTER:-

An inductor filter consists of an inductor which is connected in series, so also named as series inductor filter. The pulsating output of the rectifier is applied across the terminal of the filter circuit. The property of an inductor to block AC and provides zero resistance to DC is used in filtering circuit. When the value of DC output from the rectifier is more than the average value then the rectifier store the excess current in the form of magnetic energy.

When the value of DC from the rectifier is less than the average value then the inductor release the stored magnetic energy in order to balance the effect of the low value of DC. In this way series inductor filter maintains the regulated DC supply. Moreover, inductor blocks the AC ripples present in the output voltage of rectifier; thus, smooth DC signal can be obtained.

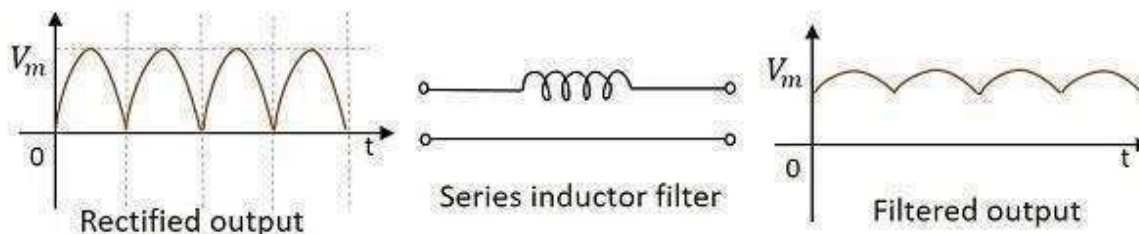

Due to the presence of that leakage A.C component the output is pulsating one.

### 3.3.2 CAPACITOR FILTER:-

A Capacitor filter consists of a capacitor which is connected in parallel with the load. During the rise of voltage cycle it gets charge and this charge is supplied to the load during the fall in the voltage cycle. This process is repeated for each cycle and thus the ripple is reduced across the load. It is popular because of its low cost, small size, less weight and good characteristics.

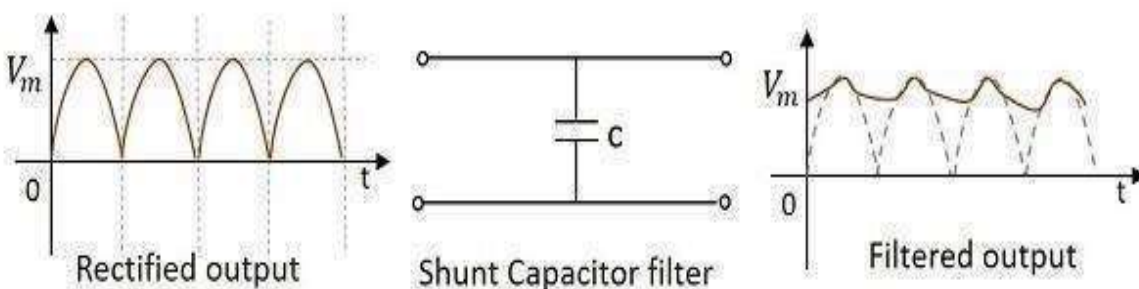

### 3.3.3 CHOKE INPUT FILTER:-

This filter circuit consists of an inductor  $L$  which is connected in series with the rectifier output and a capacitor  $C$  which is connected across the load. The inductor has low DC resistance and extremely high AC reactance. Thus, ripples get filtered through choke coil. Some of the residual ripples if present in filtered signal from inductor coil will get bypassed through the capacitor. The reason behind this is that capacitor allows AC and block DC.

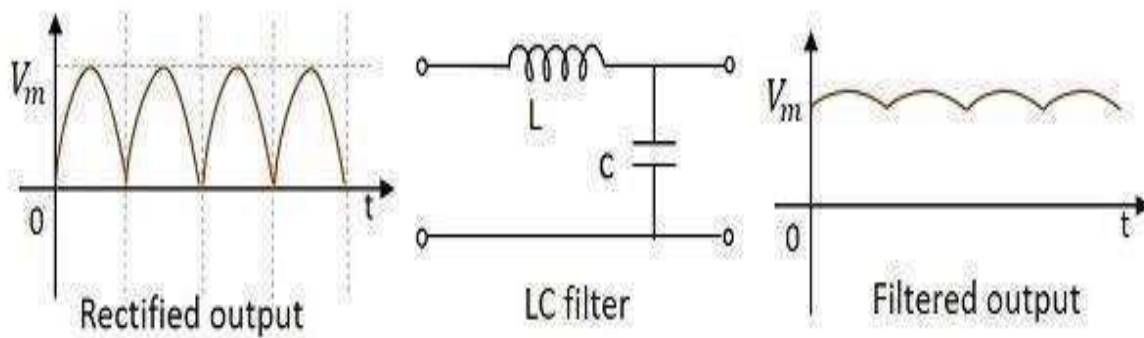

### 3.3.4. CAPACITOR INPUT FILTER:-

It consists of a capacitor  $C_1$  which is connected across the rectifier output, a choke  $L$  in series and a capacitor  $C_2$  which is connected across the load  $R_L$ .

The output voltage coming from rectifier also consists of AC components. Thus it is a crucial need to remove these AC ripples to improve the performance of the device. The output from the rectifier is directly applied to the input capacitor. The capacitor provides a low impedance to AC ripples present in the output voltage and high resistance to DC voltage. Therefore, most of the AC ripples get bypassed through the capacitor in input stage only.

The residual AC components which are still present in filtered DC signal gets filtered when they pass through the inductor coil and through the capacitor connected parallel across the load. In this way, the efficiency of filtering increases multiple times.

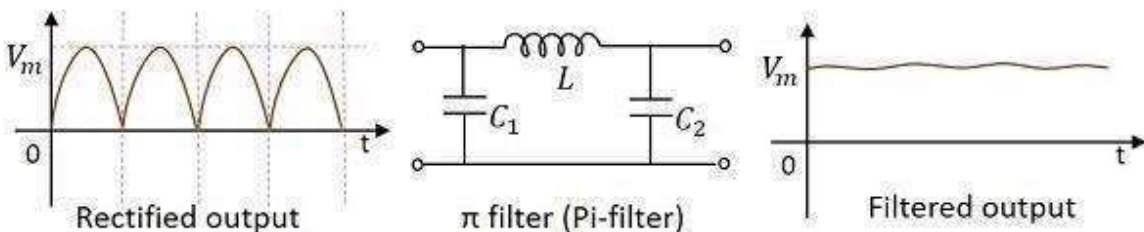

## UNIT-4: TRANSISTORS

### 4.1 PRINCIPLE OF BIPOLAR JUNCTION TRANSISTOR:

The transistor is a semiconductor device which transfers a weak signal from low resistance circuit to high resistance circuit. The words trans mean transfer property and istor mean resistance property offered to the junctions. In other words, it is a switching device which regulates and amplifies the electrical signal like voltage or current.

The transistor consists of two PN diode connected back to back. It has three terminals namely emitter, base and collector. The base is the middle section which is made up of thin layers. The right part of the diode is called emitter diode and the left part is called collector-base diode. These names are given as per the common terminal of the transistor. The emitter-base junction of the transistor is connected to forward bias and the collector-base junction is connected in reverse bias which offers a high resistance.

#### Transistor Symbols

There are two types of transistor, namely NPN transistor and PNP transistor. The transistor which has two blocks of n-type semiconductor material and one block of P-type semiconductor material is known as NPN transistor. Similarly, if the material has one layer of N-type material and two layers of P-type material then it is called PNP transistor. The symbol of NPN and PNP is shown in the figure below.

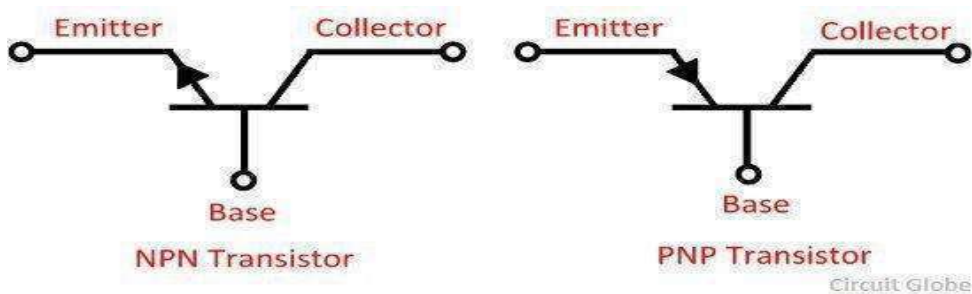

The arrow in the symbol indicates the direction of flow of conventional current in the emitter with forward biasing applied to the emitter-base junction. The only difference between the NPN and PNP transistor is in the direction of the current.

#### Transistor Terminals

The transistor has three terminals namely, emitter, collector and base. The terminals of the diode are explained below in details.

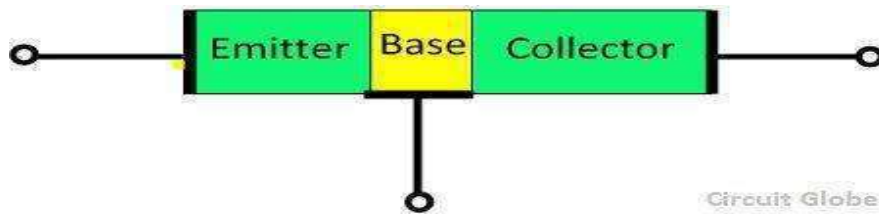

**Emitter** – The section that supplies the large section of majority charge carrier is called emitter. The emitter is always connected in forward biased with respect to the base so that it supplies the majority charge carrier to the base. The emitter-base junction injects a large amount of majority charge carrier into the base because it is heavily doped and moderate in size.

**Collector** – The section which collects the major portion of the majority charge carrier supplied by the emitter is called a collector. The collector-base junction is always in reverse bias. Its main function is to remove the majority charges from its junction with the base. The collector section of the transistor is moderately doped, but larger in size so that it can collect most of the charge carrier supplied by the emitter.

**Base** – The middle section of the transistor is known as the base. The base forms two circuits, the input circuit with the emitter and the output circuit with the collector. The emitter-base circuit is in forward biased and offered the low resistance to the circuit. The collector-base junction is in reverse bias and offers the higher resistance to the circuit. The base of the transistor is lightly doped and very thin due to which it offers the majority charge carrier to the base.

### Working of Transistor

Usually, silicon is used for making the transistor because of their high voltage rating, greater current and less temperature sensitivity. The emitter-base section kept in forward biased constitutes the base current which flows through the base region. The magnitude of the base current is very small. The base current causes the electrons to move into the collector region or create a hole in the base region.

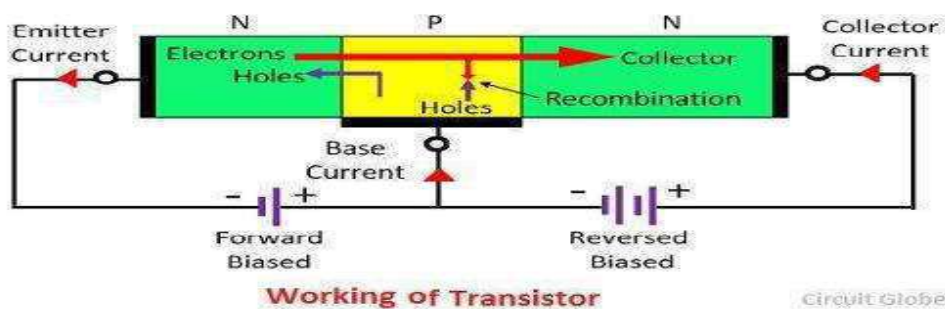

The base of the transistor is very thin and lightly doped because of which it has less number of electrons as compared to the emitter. The few electrons of the emitter are combined with the hole of the base region and the remaining electrons are moved towards the collector region and constitute the collector current. Thus we can say that the large collector current is obtained by varying the base region.

#### 4.2 DIFFERENT MODES OF OPERATION OF TRANSISTOR:

When the emitter junction is in forward biased and the collector junction is in reverse bias, then it is said to be in the active region. The transistor has two junctions which can be biased in different ways. The different working conduction of the transistor is shown in the table below.

CONDITION	EMITTER JUNCTION (EB)	COLLECTOR JUNCTION (CB)	REGION OF OPERATION
FR	Forward-biased	Reversed-biased	Active
FF	Forward-biased	Forward-biased	Saturation
RR	Reversed-biased	Reversed-biased	Cut-off
RF	Reversed-biased	Forward-biased	Inverted

**FR** – In this case, the emitter-base junction is connected in forward biased and the collector-base junction is connected in reverse biased. The transistor is in the active region and the collector current depends on the emitter current. The transistor, which operates in this region, is used for amplification.

**FF** – In this condition, both the junction is in forward biased. The transistor is in saturation and the collector current becomes independent of the base current. The transistors act like a closed switch.

**RR** – Both the current are in reverse biased. The emitter does not supply the majority charge carrier to the base and carriers current are not collected by the collector. Thus the transistors act like a closed switch.

**RF** – The emitter-base junction is in reverse bias and the collector-base junction is kept in forward biased. As the collector is lightly doped as compared to the emitter junction it does not supply the majority charge carrier to the base. Hence poor transistor action is achieved.

### 4.3 CURRENT COMPONENTS OF IN A TRANSISTOR:

The conduction of current in NPN transistor is owing to electrons and in PNP transistor, it is owing to holes. The direction of current flow will be in opposite direction. Here, we can discuss the current components in a PNP transistor with common base configuration. The emitter-base junction ( $J_E$ ) is forward biased and the collector-base junction ( $J_C$ ) is reversed biased as shown in figure. All the current components related to this transistor are shown here.

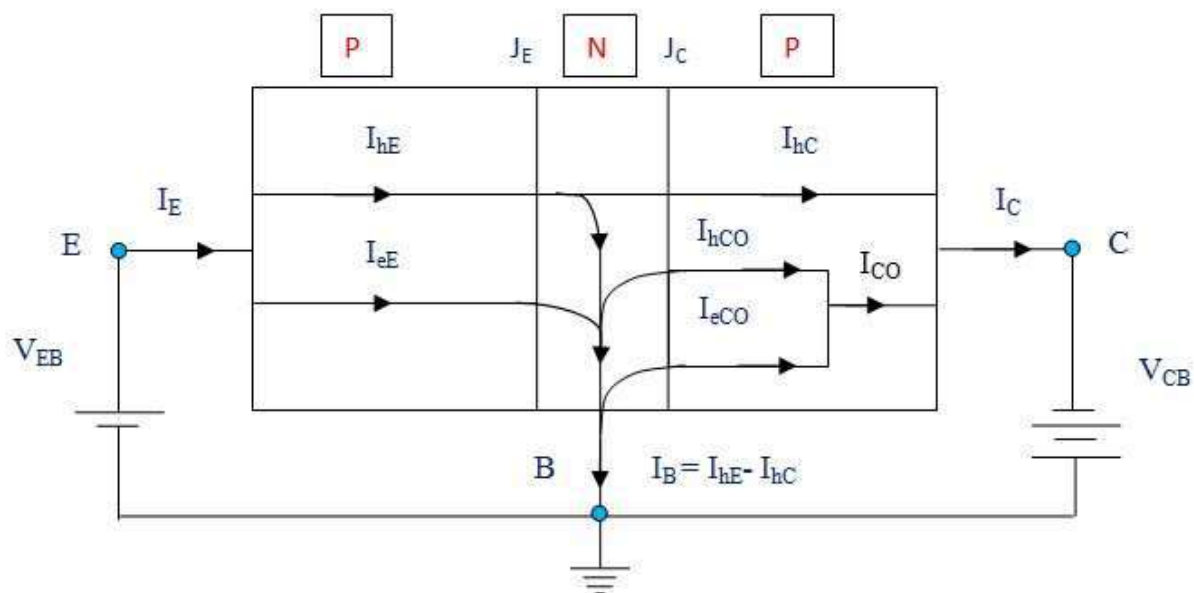

The current arrives the transistor through the emitter and this current is called emitter current ( $I_E$ ). This current consists of two constituents – **Hole current** ( $I_{hE}$ ) and **Electron current** ( $I_{eE}$ ).  $I_{eE}$  is due to passage of electrons from base to emitter and  $I_{hE}$  is due to passage of holes from emitter to base.

$$I_E = I_{hE} + I_{eE}$$

Normally, the emitter is heavily doped compared to base in industrial transistor. So, the Electron current is negligible compared to Hole current. Thus we can conclude that, the whole emitter current in this transistor is due to the passage of holes from the emitter to the base.

Some of the holes which are crossing the junction  $J_E$  (emitter junction) combines with the electrons present in the base (N-type). Thus, every holes crossing  $J_E$  will not arrive at  $J_C$ . The remaining holes will reach the collector junction which produces the hole current component,  $I_{hC}$ . There will be bulk recombination in the base and the current leaving the base will be

$$I_B = I_{hE} - I_{hC}$$

The electrons in the base which are lost by the recombination with holes (injected into the base across  $J_E$ ) are refilled by the electrons that enter into the base region. The holes which are arriving at the collector junction ( $J_C$ ) will cross the junction and it will go into the collector region.

When the emitter circuit is open circuited, then  $I_E = 0$  and  $I_{hC} = 0$ . In this condition, the base and collector will perform as reverse biased diode. Here, the collector current,  $I_C$  will be same as reverse saturation current ( $I_{CO}$  or  $I_{CBO}$ ).

$I_{CO}$  is in fact a small reverse current which passes through the PN junction diode. This is due to thermally generated minority carriers which are pushed by barrier potential. This reverse current increase; if the junction is reverse biased and it will have the same direction as the collector current. This current attains a saturation value ( $I_0$ ) at moderate reverse biased voltage.

When the emitter junction is at forward biased (in active operation region), then the collector current will become

$$I_C = \alpha I_E + I_{CO}$$

The  $\alpha$  is the large signal current gain which is a fraction of the emitter current which comprises of  $I_{hC}$ .

When the emitter is at closed condition, then  $I_E \neq 0$  and collector current will be

$$I_C = I_{CO} + I_{hC}$$

In a PNP transistor, the reverse saturation current ( $I_{CBO}$ ) will comprises of the current due to the holes passing through the collector junction from the base to collector region ( $I_{hCO}$ ) and the current due to the electrons which are passing through the collector junction in the opposite direction ( $I_{eCO}$ ).

$$\text{Therefore, } I_{CO} = I_{hCO} + I_{eCO}$$

The total current entering into the transistor will be equal to the total current leaving the transistor (according to Kirchhoff's current law).

$$\text{So, } I_E = I_C + I_B \text{ or } I_E = -(I_C + I_B)$$



#### 4.4 TRANSISTOR AS AN AMPLIFIER:-

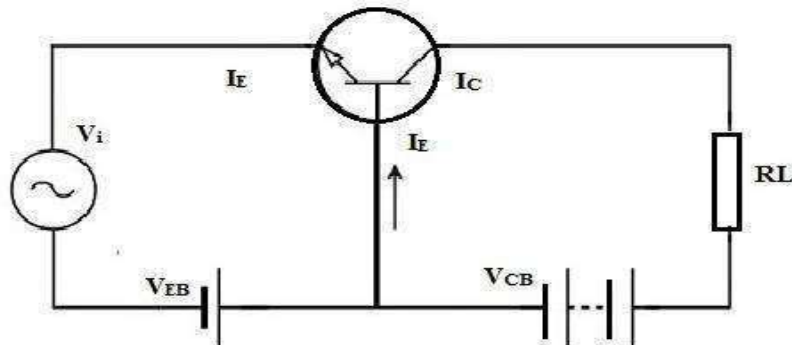

A transistor can be used as **an amplifier** by enhancing the weak signal's strength. With the help of the following transistor amplifier circuit, one can get an idea about how the transistor circuit works as an amplifier circuit.

In the below circuit, the input signal can be applied among the emitter-base junction and the output across the  $R_c$  load connected in the collector circuit.

For accurate amplification, always remember that the input is connected in forward-biased whereas the output is connected in reverse-biased. For this reason, in addition to the signal, we apply DC voltage ( $V_{EE}$ ) in the input circuit as shown in the above circuit.

Generally, the input circuit includes low resistance as a result; a little change will occur in signal voltage at the input which leads to a significant change within the emitter current. Because of the transistor act, emitter current change will cause the same change within the collector circuit.

At present, the flow of collector current through an  $R_c$  generates a huge voltage across it. Therefore, the applied weak signal at the input circuit will come out in the amplified form at the collector circuit in the output. In this method, the transistor performs as an amplifier.

## 4.5 TRANSISTOR CIRCUIT CONFIGURATION & ITS CHARACTERISTICS:

A transistor can be connected in a circuit in the following three ways:

- common base connection
- common emitter connection
- common collector connection

### 4.5.1 COMMON BASE CONNECTION

Here the base terminal is common to both input and output circuit. The common base configurations or modes are as shown in the figure below. Here, the common base mode of NPN transistor and PNP transistor are shown separately.

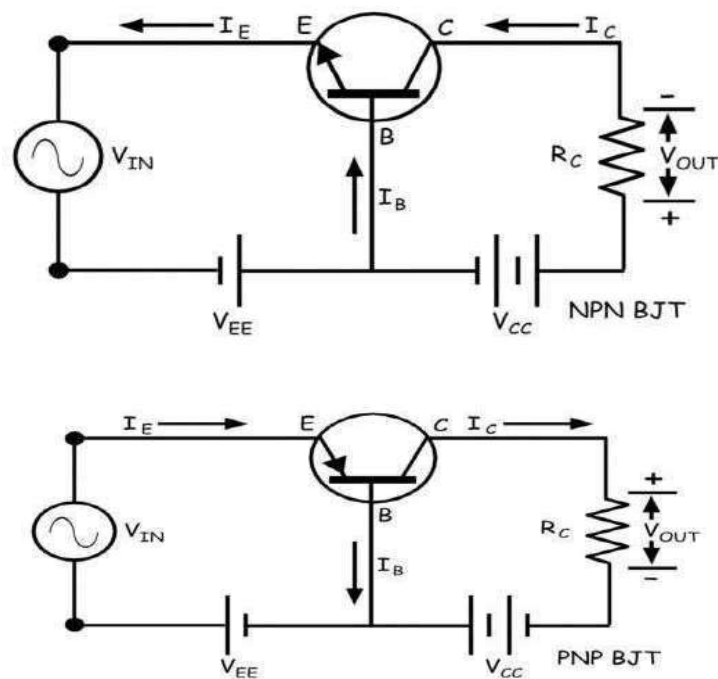

Here emitter-base circuit is taken as input circuit and collector base circuit as output circuit.

### Current Gain

Here the input current is emitter current  $I_E$  and output current is collector current  $I_C$ . The current gain is considered as when we only consider the dc biasing voltages of the circuit and no alternating signal is applied in the input.

$$\alpha_{(dc)} = \frac{I_C}{I_E}$$

Now if we consider the alternating signal applied to the input then the current amplification factor ( $\alpha$ ) at a constant collector-base voltage, would be

$$\alpha = \frac{\Delta I_C}{\Delta I_E}$$

Here it is seen that neither of current gain and current amplification factor has value more than unity since collector current in no way can be more than emitter current. But as we know that the emitter current and collector current are nearly equal in a bipolar junction transistor, these ratios would be very near to unity. The value generally ranges from 0.9 to even 0.99.

### Expression of Collector Current

- If the emitter circuit is open, there will be no emitter current ( $I_C = 0$ ). But in this condition, there will be a tiny current flowing through the collector region. This is because of flow of minority charge carriers and this is the reverse leakage current.
- As this current flow through collector and base keeping the emitter terminal open, the current is denoted as  $I_{CBO}$ . In small power rated transistor the reverse leakage current  $I_{CBO}$  is quite small and generally, we neglect it during calculations but in high power rated transistor this leakage current cannot be neglected.
- This current is highly dependent on the temperature so at high temperatures the reverse leakage current  $I_{CBO}$  cannot be neglected during calculations.

$$I_C = \alpha I_E + I_{CBO}$$

$$\Rightarrow I_C = \alpha(I_C + I_B) + I_{CBO}$$

$$\Rightarrow I_C(1 - \alpha) = \alpha I_B + I_{CBO}$$

$$\Rightarrow I_C = \frac{\alpha}{1 - \alpha} I_B + \frac{1}{1 - \alpha} I_{CBO}$$

This expression proves that collector current also depends on base current.

### Characteristic of Common Base Connection

## Input Characteristic

This is drawn between input current and input voltage of the transistor itself. The input current is emitter current ( $I_E$ ) and the input voltage is emitter-base voltage ( $V_{EB}$ ). After crossing emitter-base junction forward barrier potential emitter current ( $I_E$ ) starts increasing rapidly with increasing emitter-base voltage ( $V_{EB}$ ).

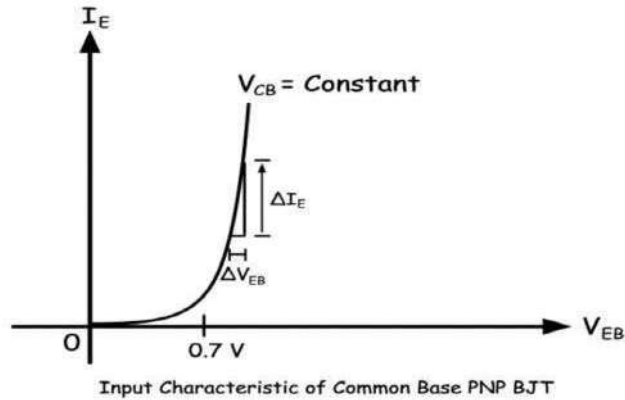

The input resistance of the circuit is the ratio of change in emitter-base voltage ( $\Delta V_{EB}$ ) to emitter current ( $\Delta I_E$ ) at a constant collector-base voltage ( $V_{CB} = \text{Constant}$ ). As the change in emitter current is quite large compared to the change in emitter-base voltage ( $\Delta I_E \gg \Delta V_{EB}$ ), the input resistance of the common base transistor is quite small.

$$r_o = \frac{\Delta V_{CB}}{\Delta I_C} \text{ When, } I_E = \text{Constant}$$

## Output Characteristic

- Collector current gets only constant value when there is sufficient reverse biased established between base and collector region. This is why there is a rise of collector current with an increase of collector-base voltage when this voltage has very low value.
- But after a certain collector-base voltage the collector-base junction gets sufficient reverse biased and hence the collector current becomes constant for a certain emitter current and it entirely depends on the emitter current.

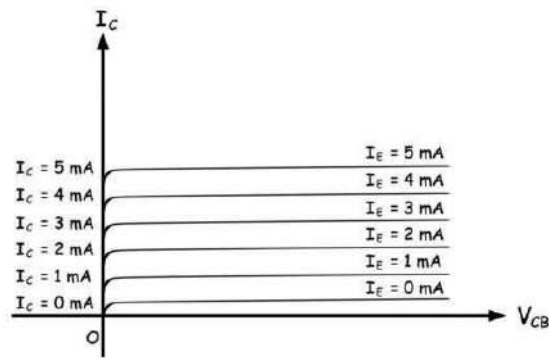

The ratio of change in collector-base voltage to the change in collector current is defined as the output resistance of common base mode of a transistor. Naturally, the value of output resistance is very high in the common base mode of a transistor.

$$r_o = \frac{\Delta V_{CB}}{\Delta I_C} \text{ When, } I_E = \text{Constant}$$

#### 4.5.2 COMMON EMITTER CONNECTION

Common Emitter Transistor is the most commonly used transistor connection. Here the emitter terminal is common for both input and output circuit. The circuit connected between base and emitter is the input circuit and the circuit connected between collector and emitter is the output circuit. The common emitter mode of NPN transistor and PNP transistor are shown separately in the figure below.

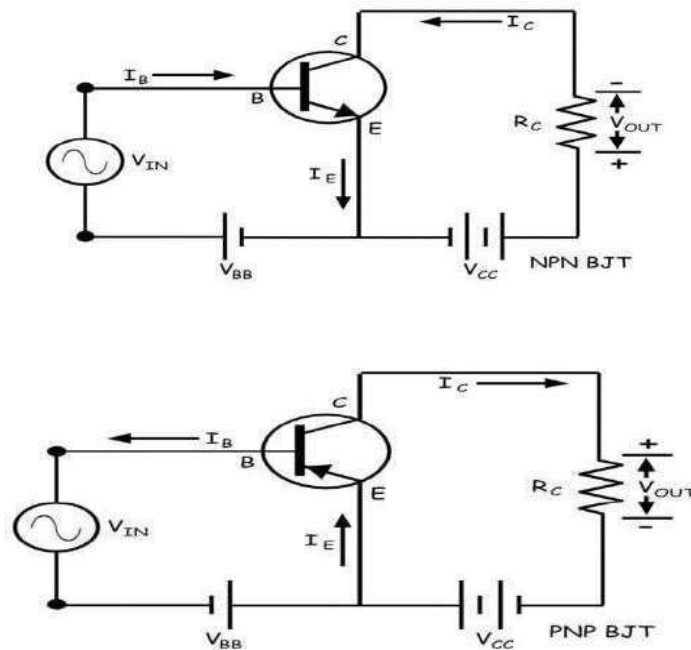

## Current Gain

In common emitter configuration, the input current is base current ( $I_B$ ) and the output current is collector current ( $I_C$ ). In bipolar junction transistor, the base current controls the collector current. The ratio of change in collector current ( $\Delta I_C$ ) to change in base current ( $\Delta I_B$ ) is defined as the current gain of common emitter transistor. In a bipolar junction transistor, the emitter current ( $I_E$ ) is the sum of the base current ( $I_B$ ) and collector current ( $I_C$ ).

If base current changes, the collector current also changes and as a result the emitter current gets also changed accordingly.

$$\beta = \frac{\Delta I_C}{\Delta I_B}$$

Again the ratio of change of collector current to the corresponding change in emitter current is denoted by  $\alpha$

As the value of base current is quite low compared to the collector current ( $I_B \ll I_C$ ), the current gain in a common emitter transistor is quite high and it ranges from 20 to 500.

## Characteristic of Common Emitter Transistor

- In common emitter mode of the transistor, there are two circuits – input circuit and the output circuit. In the input circuit, the parameters are base current and base-emitter voltage.
- The characteristic curve drawn against variations of base current and base-emitter voltage is input characteristic of a common emitter transistor.

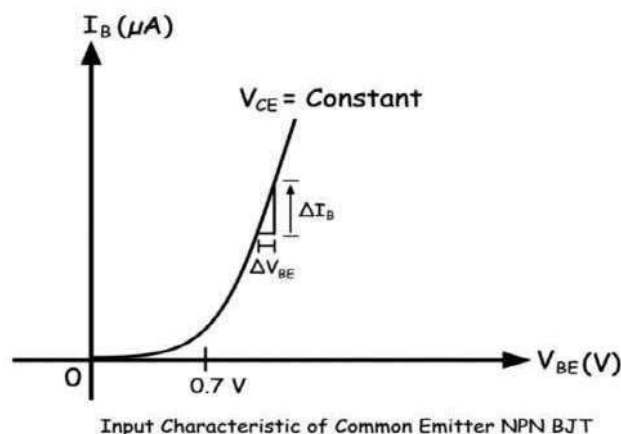

Input resistance of the circuit is:

$$r_i = \frac{\Delta V_{BE}}{\Delta I_B} \text{ When, } V_{CE} \text{ is constant}$$

## Output Characteristic of Common Emitter Transistor

- The output characteristic is drawn against variations of output current and the output voltage of the transistor. The collector current is output current and collector-emitter voltage is the output voltage of the transistor.

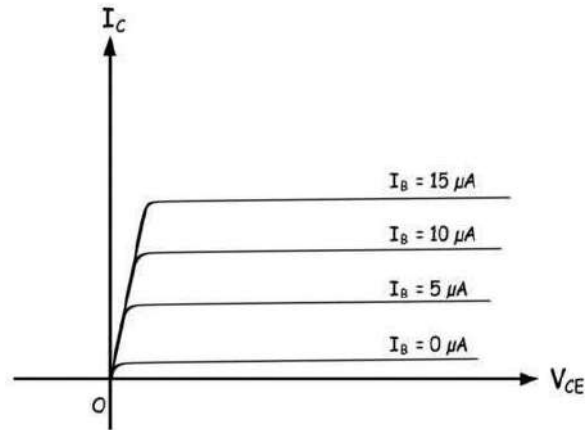

The output resistance would be

$$r_o = \frac{\Delta V_{CE}}{\Delta I_C} \text{ When, } I_B \text{ is constant}$$

## COMMON COLLECTOR:

In common collector configuration the input circuit is between base and collector terminal and the output circuit is between emitter and collector terminal.

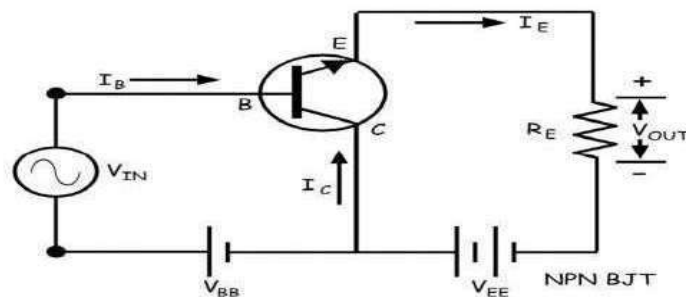

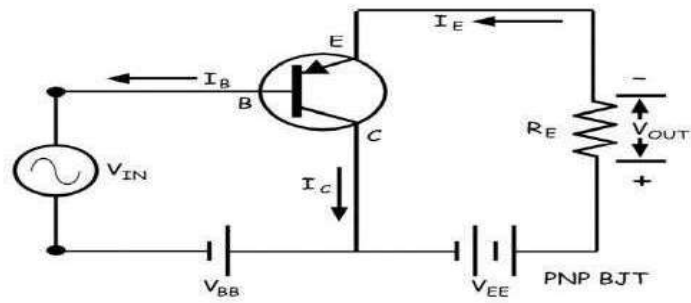

The ratio of change of emitter current to change of base current is defined as the current gain of common collector configuration. This is denoted as,

$$\frac{I_E}{I_B}$$

The current amplification factor of the circuit is the ratio of change of emitter current to change of base current when a time-varying signal is applied to the input.

$$\gamma = \frac{\Delta I_E}{\Delta I_B}$$

### Input Characteristic of Common Collector Transistor

The input current is base current and input voltage of the transistor is base-collector voltage. The base-collector junction is reverse biased and hence with increasing base-collector voltage the reverse biasing of the junction increases. This causes base current to decrease slightly with the increase in base-collector voltage.

Input Characteristic of Common Collector Transistor

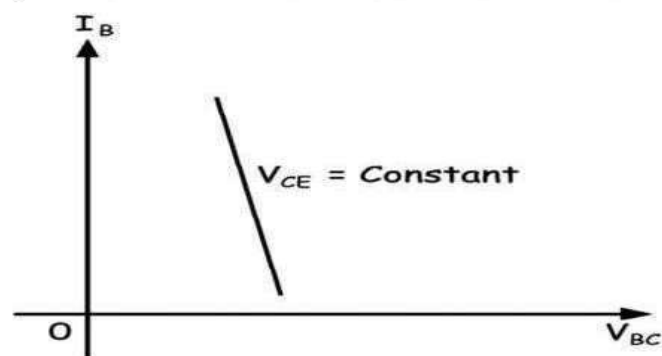

### Output Characteristic of Common Collector Transistor

The output characteristic of a common collector transistor is nearly the same as the output characteristic of a common emitter transistor. The only difference that here



in the case of common collector configuration the output current is emitter current instead of collector current as in the case of common emitter configuration. Here also for a fixed base current, the emitter current increases linearly with increasing collector-emitter voltage up to a certain level of this voltage and then the emitter current gets almost constant irrespective of collector-emitter voltage. Although there would be a very slow increase of emitter current with the collector-emitter voltage as shown in the characteristic curve below.

Output Characteristic of Common Collector Transistor

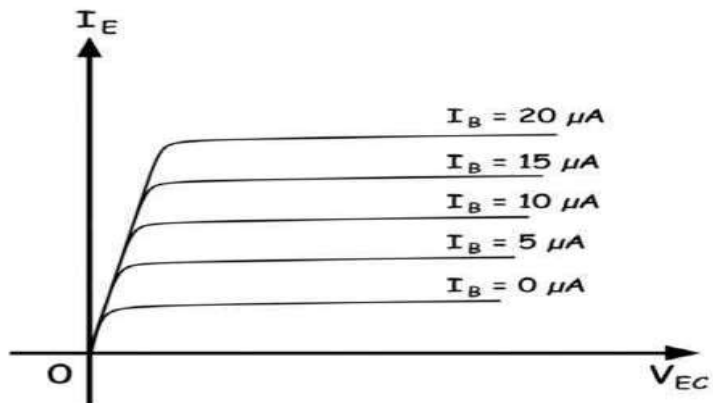

## UNIT-5: TRANSISTOR CIRCUITS

### 5.1 TRANSISTOR BIASING:-

- ✓ Biasing is the process of providing DC voltage which helps in functioning of the circuit.
- ✓ A transistor is biased in order to make the emitter base junction forward biased and collector base junction reverse biased, so that it maintains in active region, to work as an amplifier.
- ✓ The proper flow of zero signal collector current and the maintenance of proper collector emitter voltage during the passage of a signal is known as transistor biasing.
- ✓ The circuit which provides transistor biasing is known as biasing circuit.
- ✓ Transistor biasing is basically classified into 4 types:

(a) Fixed biasing

(b) Emitter stabilized biasing

(c) Voltage divider biasing

(d) DC biasing with voltage feedback

### 5.2 STABILISATION:

For a transistor to be operated as a faithful amplifier, the operating point should be stabilized. Let us have a look at the factors that affect the stabilization of operating point.

#### Factors affecting the operating point

The main factor that affects the operating point is the temperature. The operating point shifts due to change in temperature.

As temperature increases, the values of  $I_{CE}$ ,  $\beta$ ,  $V_{BE}$  gets affected.

- $I_{CBO}$  gets doubled (for every  $10^\circ$  rise)
- $V_{BE}$  decreases by 2.5mv (for every  $1^\circ$  rise)

So the main problem which affects the operating point is temperature. Hence operating point should be made independent of the temperature so as to achieve stability. To achieve this, biasing circuits are introduced.

## Stabilization

The process of making the operating point independent of temperature changes or variations in transistor parameters is known as Stabilization.

Once the stabilization is achieved, the values of  $I_C$  and  $V_{CE}$  become independent of temperature variations or replacement of transistor. A good biasing circuit helps in the stabilization of operating point.

## Need for Stabilization

Stabilization of the operating point has to be achieved due to the following reasons.

- Temperature dependence of  $I_C$
- Individual variations
- Thermal runaway

Let us understand these concepts in detail.

- Temperature Dependence of  $I_C$

As the expression for collector current  $I_C$  is

$$\begin{aligned} I_C &= \beta I_B + I_{CEO} \\ &= \beta I_B + (\beta + 1) I_{CBO} \end{aligned}$$

The collector leakage current  $I_{CBO}$  is greatly influenced by temperature variations. To come out of this, the biasing conditions are set so that zero signal collector current  $I_C = 1$  mA. Therefore, the operating point needs to be stabilized i.e. it is necessary to keep  $I_C$  constant.

- Individual Variations

As the value of  $\beta$  and the value of  $V_{BE}$  are not same for every transistor, whenever a transistor is replaced, the operating point tends to change. Hence it is necessary to stabilize the operating point.

- Thermal Runaway

As the expression for collector current  $I_C$  is

$$\begin{aligned} I_C &= \beta I_B + I_{CEO} \\ &= \beta I_B + (\beta + 1) I_{CBO} \end{aligned}$$

The flow of collector current and also the collector leakage current causes heat dissipation. If the operating point is not stabilized, there occurs a cumulative effect which increases this heat dissipation.

The self-destruction of such an un-stabilized transistor is known as Thermal run away.

In order to avoid thermal runaway and the destruction of transistor, it is necessary to stabilize the operating point, i.e., to keep  $I_C$  constant.

### **STABILITY FACTOR:**

It is understood that  $I_C$  should be kept constant in spite of variations of  $I_{CBO}$  or  $I_{CO}$ . The extent to which a biasing circuit is successful in maintaining this is measured by Stability factor. It denoted by  $S$ .

The rate of change of collector current  $I_C$  with respect to the collector leakage current  $I_{CO}$  at constant  $\beta$  and  $I_B$  is called Stability factor.

$$S = d I_C / d I_{CO} \text{ at constant } I_B \text{ and } \beta$$

Hence we can understand that any change in collector leakage current changes the collector current to a great extent. The stability factor should be as low as possible so that the collector current doesn't get affected.  $S=1$  is the ideal value.

The general expression of stability factor for a CE configuration can be obtained as under.

$$I_C = \beta I_B + (\beta + 1) I_{CO}$$

Differentiating above expression with respect to  $I_C$ , we get

$$1 = \beta \{d I_B / d I_C\} + \{(\beta + 1)\} d I_{CO} / d I_C$$

Or

$$1 = \beta d I_B / d I_C + (\beta + 1) S$$

$$\text{Since } d I_{CO} / d I_C = 1 / S$$

Or

$$S = (\beta + 1) / \{1 - \beta (d I_B / d I_C)\}$$

Hence the stability factor  $S$  depends on  $\beta$ ,  $I_B$  and  $I_C$ .

## 5.4 DIFFERENT METHOD OF TRANSISTORS BIASING:

### 5.4.1 FIXED BIASING:

- ✓ Fixed biasing is also known as base biasing.

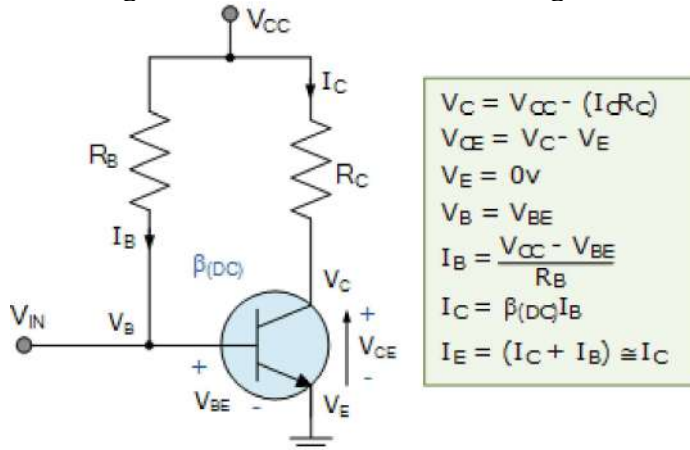

- ✓ The above circuit shown is called as a “fixed base bias circuit”, because the transistors base current,  $I_B$  remains constant for given values of  $V_{CC}$ , and therefore the transistors operating point must also remain fixed.
- ✓ This two resistor biasing network is used to establish the initial operating region of the transistor using a fixed current bias.
- ✓ This type of transistor biasing arrangement is also beta dependent biasing as the steady-state condition of operation is a function of the transistors beta  $\beta$  value, so the biasing point will vary over a wide range for transistors of the same type as the characteristics of the transistors will not be exactly the same.
- ✓ The emitter diode of the transistor is forward biased by applying the required positive base bias voltage via the current limiting resistor  $R_B$ .
- ✓ Assuming a standard bipolar transistor, the forward base-emitter voltage drop would be 0.7V. Then the value of  $R_B$  is simply:  $(V_{CC} - V_{BE})/I_B$  where  $I_B$  is defined as  $I_C/\beta$ .
- ✓ With this single resistor type of biasing arrangement the biasing voltages and currents do not remain stable during transistor operation and can vary enormously.
- ✓ Also the operating temperature of the transistor can adversely affect the operating point.

### 5.4.2 EMITTER STABILIZED BIASING:

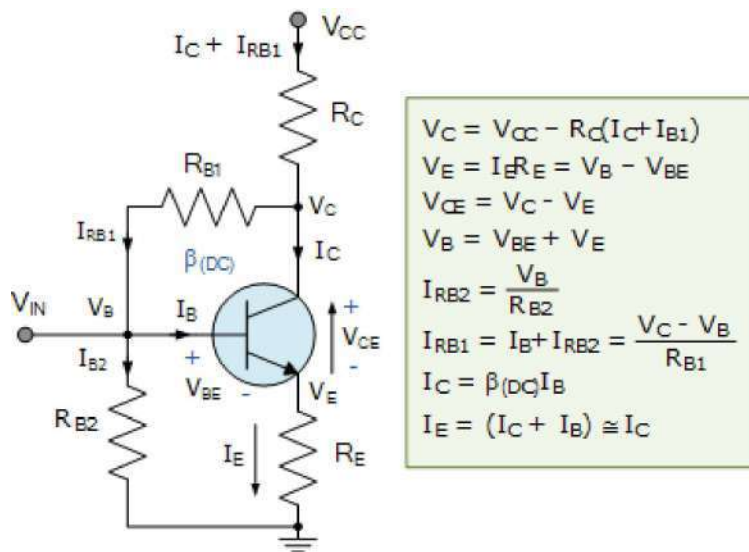

- ✓ This type of transistor biasing configuration, often called self-emitter biasing, uses both emitter and base-collector feedback to stabilize the collector current even further.
- ✓ This is because resistors  $R_{B1}$  and  $R_E$  as well as the base-emitter junction of the transistor are all effectively connected in series with the supply voltage,  $V_{CC}$ .
- ✓ The downside of this emitter feedback configuration is that it reduces the output gain due to the base resistor connection.
- ✓ The collector voltage determines the current flowing through the feedback resistor,  $R_{B1}$  producing what is called “degenerative feedback”.
- ✓ The current flowing from the emitter,  $I_E$  (which is a combination of  $I_C + I_B$ ) causes a voltage drop to appear across  $R_E$  in such a direction, that it reverse biases the base-emitter junction.
- ✓ So if the emitter current increases, due to an increase in collector current, voltage drop  $I \cdot R_E$  also increases. Since the polarity of this voltage reverse biases the base-emitter junction,  $I_B$  automatically decrease. Therefore the emitter current increase less than it would have done had there been no self-biasing resistor.
- ✓ Generally, resistor values are set so that the voltage dropped across the emitter resistor  $R_E$  is approximately 10% of  $V_{CC}$  and the current flowing through resistor  $R_{B1}$  is 10% of the collector current  $I_C$ .
- ✓ Thus this type of transistor biasing configuration works best at relatively low power supply voltages.

#### 5.4.3 VOLTAGE DIVIDER BIASING:

- ✓ Voltage divider biasing is also known as universal biasing.

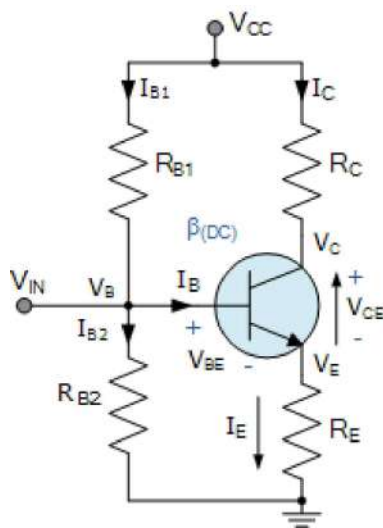

$$\begin{aligned}
 V_C &= V_{CC} - R_C I_C = (V_E + V_{CE}) \\
 V_E &= I_E R_E = V_B - V_{BE} \\
 V_{CE} &= V_C - V_E = V_{CC} - (I_C R_C + I_E R_E) \\
 V_B &= V_{BE} + V_E = V_{RB2} = \left( \frac{R_{B2}}{R_{B1} + R_{B2}} \right) V_{CC} \\
 I_{B2} &= \frac{V_B}{R_{B2}} \\
 I_{B1} &= I_B + I_{B2} = \frac{V_{CC} - V_B}{R_{B1}} \\
 R_B &= \frac{R_{B1} \times R_{B2}}{R_{B1} + R_{B2}} \quad I_B = \frac{V_B - V_{BE}}{R_B + (1 + \beta) R_E} \\
 I_C &= \beta(DC) I_B \\
 I_E &= I_C + I_B = \frac{V_E}{R_E}
 \end{aligned}$$

- ✓ Here the common emitter transistor configuration is biased using a voltage divider network to increase stability.
- ✓ The name of this biasing configuration comes from the fact that the two resistors  $R_{B1}$  and  $R_{B2}$  form a voltage or potential divider network across the supply with their center point junction connected to the transistor's base terminal as shown.
- ✓ This voltage divider biasing configuration is the most widely used transistor biasing method.
- ✓ The emitter diode of the transistor is forward biased by the voltage value developed across resistor  $R_{B2}$ .
- ✓ The voltage divider network biasing makes the transistor circuit independent of changes in beta as the biasing voltages set at the transistor's base, emitter, and collector terminals are not dependent on external circuit values.
- ✓ To calculate the voltage developed across resistor  $R_{B2}$  and the voltage applied to the base terminal we simply use the voltage divider formula for resistors in series.
- ✓ Generally the voltage drop across resistor  $R_{B2}$  is much less than for resistor  $R_{B1}$ . Clearly the transistor's base voltage  $V_B$  with respect to ground will be equal to the voltage across  $R_{B2}$ .
- ✓ The amount of biasing current flowing through resistor  $R_{B2}$  is generally set to 10 times the value of the required base current  $I_B$  so that it is sufficiently high enough to have no effect on the voltage divider current or changes in Beta.

#### 5.4.4 DC BIAS WITH COLLECTOR FEEDBACK:

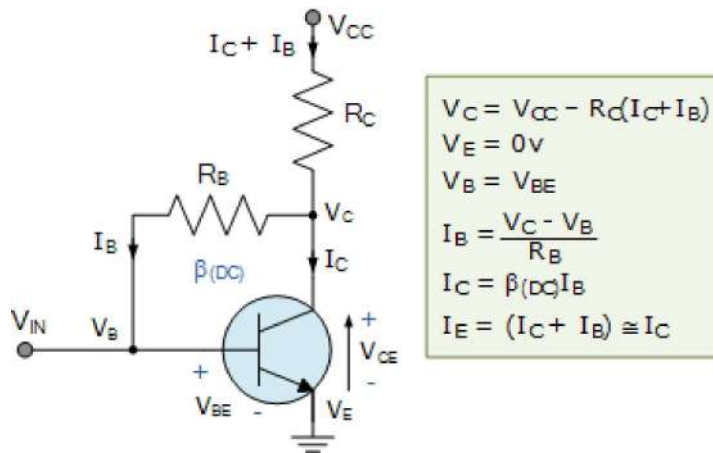

This self-biasing collector feedback configuration is another beta dependent biasing method which requires two resistors to provide the necessary DC bias for the transistor. The collector to base feedback configuration ensures that the transistor is always biased in the active region regardless of the value of Beta ( $\beta$ ). The DC base bias voltage is derived from the collector voltage  $V_C$ , thus providing good stability.

In this circuit, the base bias resistor,  $R_B$  is connected to the transistors collector C, instead of to the supply voltage rail,  $V_{CC}$ . Now if the collector current increases, the collector voltage drops, reducing the base drive and thereby automatically reducing the collector current to keep the transistors Q-point fixed. Therefore this method of collector feedback biasing produces negative feedback round the transistor as there is a direct feedback from the output terminal to the input terminal via resistor,  $R_B$ .

Since the biasing voltage is derived from the voltage drop across the load resistor,  $R_L$ , if the load current increases there will be a larger voltage drop across  $R_L$ , and a corresponding reduced collector voltage,  $V_C$ . This effect will cause a corresponding drop in the base current,  $I_B$  which in turn, brings  $I_C$  back to normal.

The opposite reaction will also occur when the transistors collector current reduces. Then this method of biasing is called self-biasing with the transistors stability using this type of feedback bias network being generally good for most amplifier designs.



## UNIT-6: TRANSISTOR CIRCUITS AND OSCILLATORS:

### 6.3 PRACTICAL CIRCUIT OF TRANSISTOR AMPLIFIER

The transistor raises the strength of a weak signal and hence acts as an amplifier. The transistor amplifier circuit is shown in the figure below. The transistor has three terminals namely emitter, base and collector. The emitter and base of the transistor are connected in forward bias and the collector-base region is in reverse bias. The forward bias means the P-region of the transistor is connected to the positive terminal of the supply and the negative region is connected to the N-terminal and in reverse bias just opposite of it has occurred.

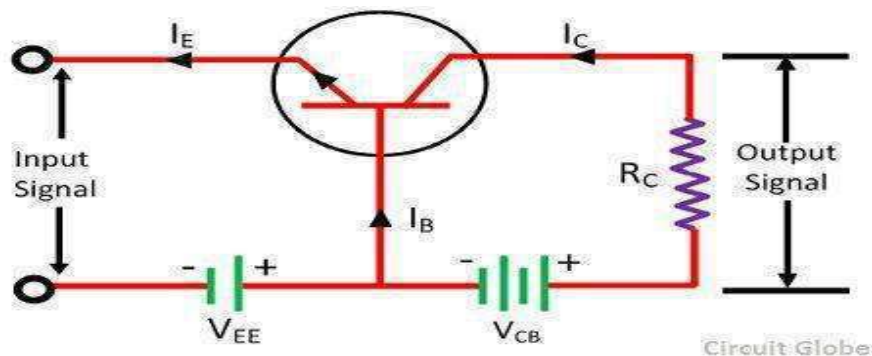

The input signal or weak signal is applied across the emitter-base and the output is obtained across the load resistor  $R_C$  which is connected in the collector circuit. The DC voltage  $V_{EE}$  is applied to the input circuit along with the input signal to achieve the amplification. The DC voltage  $V_{EE}$  keeps the emitter-base junction under the forward-biased condition regardless of the polarity of the input signal and is known as a bias voltage.

When a weak signal is applied to the input, a small change in signal voltage causes a change in emitter current (or we can say a change of 0.1V in signal voltage causes a change of 1mA in the emitter current) because the input circuit has very low resistance. This change is almost the same in collector current because of the transistor action.

In the collector circuit, a load resistor  $R_C$  of high value is connected. When collector current flows through such a high resistance, it produces a large voltage drop across it. Thus, a weak signal (0.1V) applied to the input circuit appears in the amplified form (10V) in the collector circuit.

### 6.2 TRANSISTOR LOAD LINE ANALYSIS:

The load line analysis of a transistor means for the given value of collector-emitter voltage we find the value of collector current. This can be done by plotting the output characteristic and then determining the collector current  $I_C$  with respect to

collector-emitter voltage  $V_{CE}$ . The load line analysis can easily be obtained by determining the output characteristics of the load line analysis methods.

### 6.2.1 DC LOAD LINE & DC EQUIVALENT CIRCUIT: -

The DC load represents the desirable combinations of the collector current and the collector-emitter voltage. It is drawn when no signal is given to the input, and the transistor becomes bias.

Consider a CE NPN transistor circuit shown in the figure below where no signal is applied to the input side. For this circuit, DC condition will obtain, and the output characteristic of such a circuit is shown in the figure below.

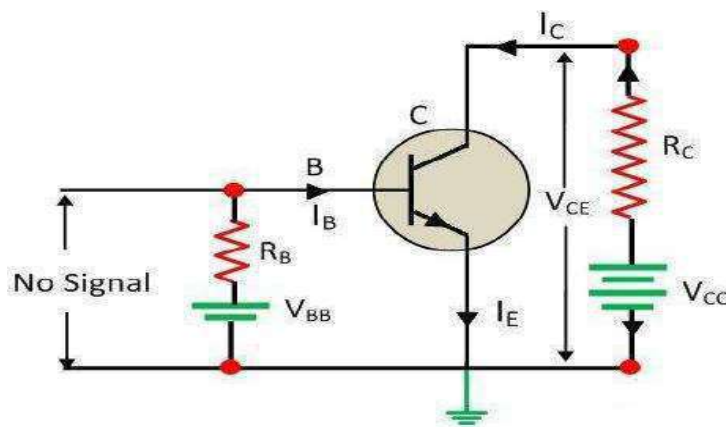

The DC load line curve of the above circuit is shown in the figure below.

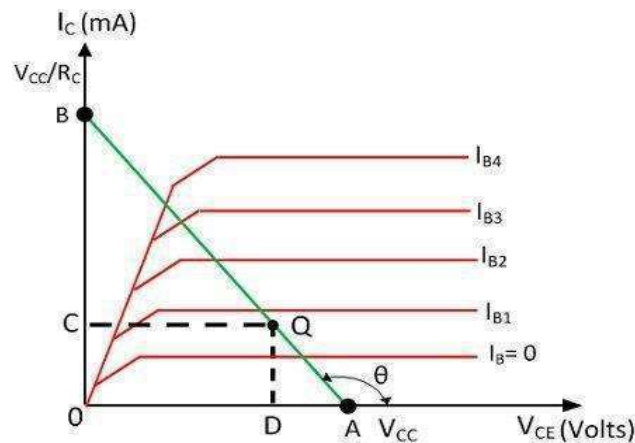

By applying Kirchoff's voltage law to the collector circuit, we get,

$$V_{CC} = V_{CE} + I_C R_C$$

$$V_{CE} = V_{CC} - I_C R_C \text{ -----equation 1}$$

The above equation shows that the  $V_{CC}$  and  $R_C$  are the constant value, and it is the first-degree equation which is represented by the straight line on the output characteristic. This load line is known as a DC load line. The input characteristic is used to determine the locus of  $V_{CE}$  and  $I_C$  point for the given value of  $R_C$ . The end point of the line are located as

1. The collector-emitter voltage  $V_{CE}$  is maximum when the collector current  $I_C = 0$  then from the equation (1) we get,

$$\begin{aligned} V_{CE} &= V_{CC} - 0 \times R_C \\ V_{CE} &= V_{CC} \end{aligned}$$

The first point A ( $OA = V_{CC}$ ) on the collector-emitter voltage axis shown in the figure above.

2. The collector current  $I_C$  becomes maximum when the collector-emitter voltage  $V_{CE} = 0$  then from the equation (1) we get,

$$0 = V_{CC} - I_C R_C$$

$$I_C = \frac{V_{CC}}{R_C}$$

This gives the second point on the collector current axis as shown in the figure above.

By adding the points A and B, the DC load line is drawn. With the help of load line, any value of collector current can be determined.

### 6.2.2 AC LOAD LINE & AC EQUIVALENT CIRCUIT: -

The DC load line discussed previously, analyzes the variation of collector currents and voltages, when no AC voltage is applied. Whereas the AC load line gives the peak-to-peak voltage, or the maximum possible output swing for a given amplifier.

We shall consider an AC equivalent circuit of a CE amplifier for our understanding.

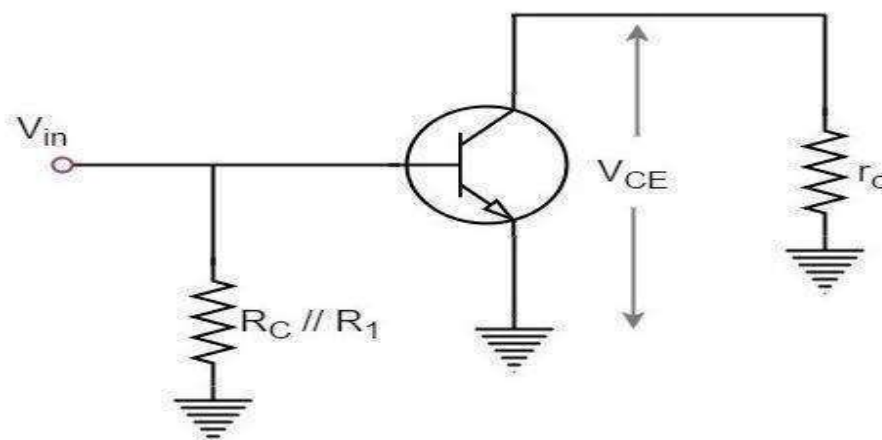

From the above figure,

$$V_{CE} = (R_C // R_1) \times I_C$$

$$r_C = (R_C // R_1)$$

For a transistor to operate as an amplifier, it should stay in active region. The quiescent point is so chosen in such a way that the maximum input signal excursion is symmetrical on both negative and positive half cycles.

Hence,

$$V_{max} = V_{CEQ} \text{ and } V_{min} = -V_{CEQ}$$

Where  $V_{CEQ}$  is the emitter-collector voltage at quiescent point

The following graph represents the AC load line which is drawn between saturation and cut off points.

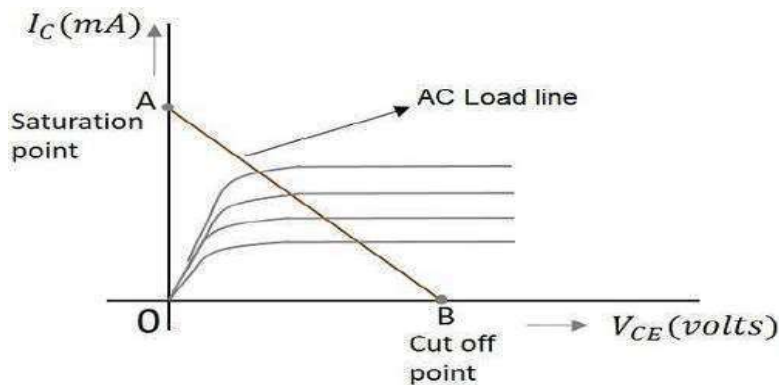

From the graph above, the current  $I_C$  at the saturation point is

$$I_{C(sat)} = I_{CQ} + (V_{CEQ}/r_C)$$

The voltage  $V_{CE}$  at the cutoff point is

$$V_{CE(off)} = V_{CEQ} + I_{CQ}r_C$$

Hence the maximum current for that corresponding  $V_{CEQ} = V_{CEQ}/(R_C//R_1)$  is

$$I_{CQ} = I_{CQ} * (R_C//R_1)$$

Hence by adding quiescent currents the end points of AC load line are

$$I_{C(sat)} = I_{CQ} + V_{CEQ}/(R_C//R_1)$$

$$V_{CE(off)} = V_{CEQ} + I_{CQ} * (R_C//R_1)$$

### AC and DC Load Line

When AC and DC Load lines are represented in a graph, it can be understood that they are not identical. Both of these lines intersect at the Q-point or quiescent point. The endpoints of AC load line are saturation and cut off points. This is understood from the figure below.

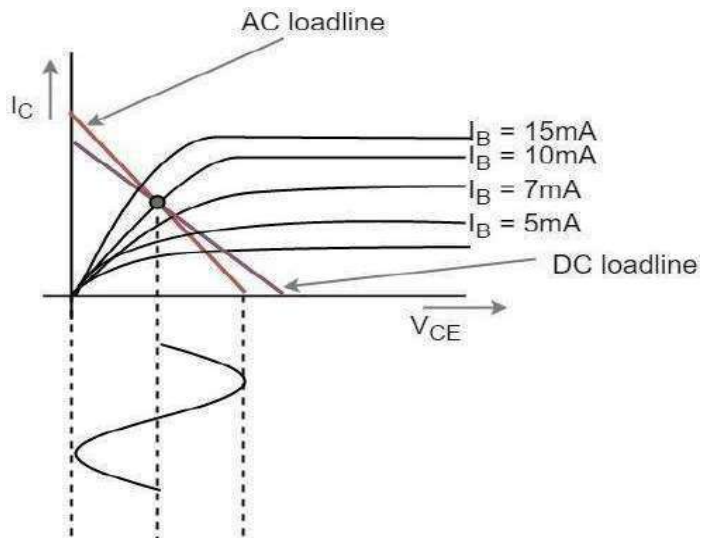

From the above figure, it is understood that the quiescent point (the dark dot) is obtained when the value of base current  $I_B$  is 10mA. This is the point where both the AC and DC load lines intersect.

### 6.3 PHASE REVERSAL:

The phase relationship between the input and output voltages can be determined by considering the effect of a positive half cycle and negative half cycle separately. Consider the positive half cycle of input signal in which terminal A is positive w.r.t B. Due to this, two voltages, ac and dc will be adding each other, increasing forward bias on base emitter junction. This increases base current. The collector current is  $\beta$  times the base current; hence the collector current will also increase. This increases the voltage drop across  $R_C$ . Since  $V_C = V_{CC} - I_C R_C$ , the increases in  $I_C$  results in a drop in collector voltage  $V_C$ , as  $V_{CC}$  is constant. Thus, as  $V_i$  increases in a positive direction,  $V_o$  goes in a negative direction and we get negative half cycle of output voltage for positive half cycle at the input.

In the negative half cycle of input, in which terminal A becomes negative w.r.t. terminal B, the ac and dc voltages will oppose each other, reducing forward bias on base-emitter p-n junction. This reduces base current. Accordingly collector current and drop across  $R_C$  both reduce, increasing the output voltage. Thus, we get positive half cycle at the output for negative half cycle at the input. Therefore, we can say that there is a phase shift of  $180^\circ$  between input and output voltages for a common emitter amplifier.

### 6.4 HYBRID PARAMETERS OR H PARAMETERS

Hybrid parameters (also known as h parameters) are known as 'hybrid' parameters as they use Z parameters, Y parameters, voltage ratio, and current ratios to represent the relationship between voltage and current in a two port network.

H parameters are useful in describing the input-output characteristics of circuits where it is hard to measure Z or Y parameters (such as a transistor). H parameters encapsulate all the important linear characteristics of the circuit, so they are very useful for simulation purposes. The relationship between voltages and current in h parameters can be represented as:

$$\begin{aligned} V_1 &= h_{11}I_1 + h_{12}V_2 \\ I_2 &= h_{21}I_1 + h_{22}V_2 \end{aligned}$$

This can be represented in matrix form as:

$$\begin{bmatrix} V_1 \\ I_2 \end{bmatrix} = \begin{bmatrix} h_{11} & h_{12} \\ h_{21} & h_{22} \end{bmatrix} \begin{bmatrix} I_1 \\ V_2 \end{bmatrix}$$

To illustrate where h parameters are useful, take the case of an ideal transformer, where Z parameters cannot be used. Since here, the relations between voltages and current in that ideal transformer would be,

$$V_1 = \frac{1}{n}V_2 \text{ and } I_1 = -nI_2$$

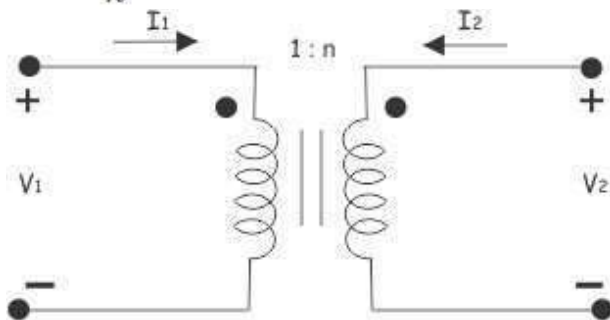

Since, in an ideal transformer voltages cannot be expressed in terms of current, it is impossible to analyze a transformer with Z parameters because a transformer does not have Z parameters. The problem can be solved by using hybrid parameters (i.e. h parameters).

### Determining h Parameters

Let us short circuit the output port of a two port network as shown below,

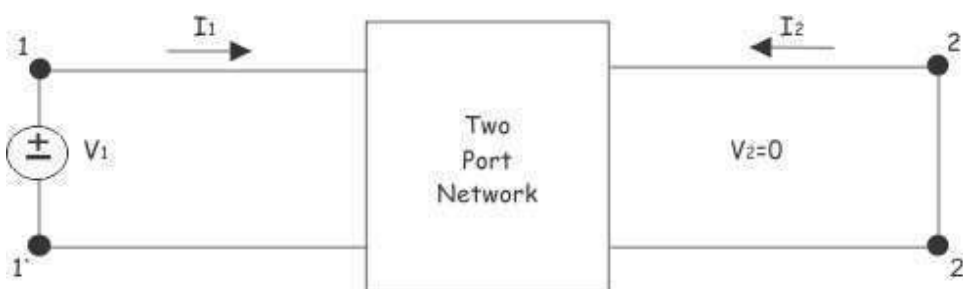

Now, ratio of input voltage to input current, at short circuited output port is:

$$\left. \frac{V_1}{I_1} \right|_{V_2 = 0} = h_{11}$$

This is referred to as the short circuit input impedance. Now, the ratio of the output current to input current at the short-circuited output port is:

$$\left. \frac{I_2}{I_1} \right|_{V_2 = 0} = h_{21}$$

This is called short-circuit current gain of the network. Now, let us open circuit the port 1. At that condition, there will be no input current ( $I_1=0$ ) but open circuit voltage  $V_1$  appears across the port 1, as shown below:

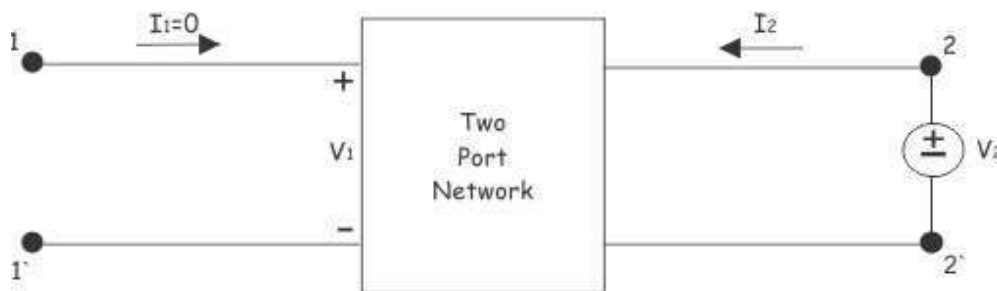

Now:

$$\left. \frac{V_1}{V_2} \right|_{I_1 = 0} = h_{12} = \textit{open circuit reverse voltage gain}$$

This is referred as reverse voltage gain because, this is the ratio of input voltage to the output voltage of the network, but voltage gain is defined as the ratio of output voltage to the input voltage of a network.

Now:

$$\left. \frac{I_2}{V_2} \right|_{I_1 = 0} = h_{22}$$

It is referred as open circuit output admittance.

To draw h parameter equivalent network of a two port network, first we have to write the equation of voltages and currents using h parameters. These are:

$$V_1 = h_{11}I_1 + h_{12}V_2 \dots\dots\dots(i)$$

$$I_2 = h_{21}I_1 + h_{22}V_2 \dots\dots\dots(ii)$$

Equation (i) can be represented as a circuit based on Kirchhoff Voltage Law:

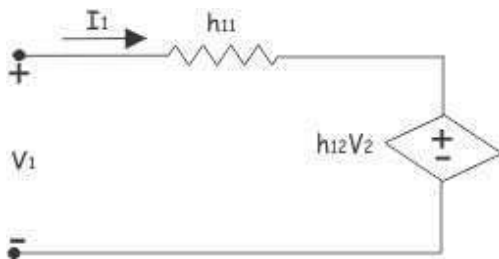

Equation (ii) can be represented as a circuit based on Kirchhoff Current Law:

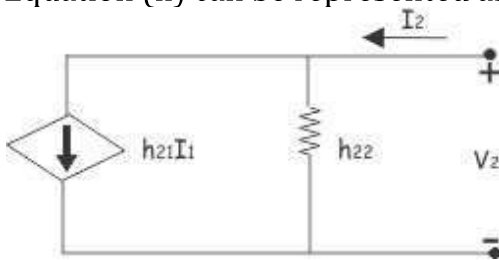

Combining these two parts of the network we get:

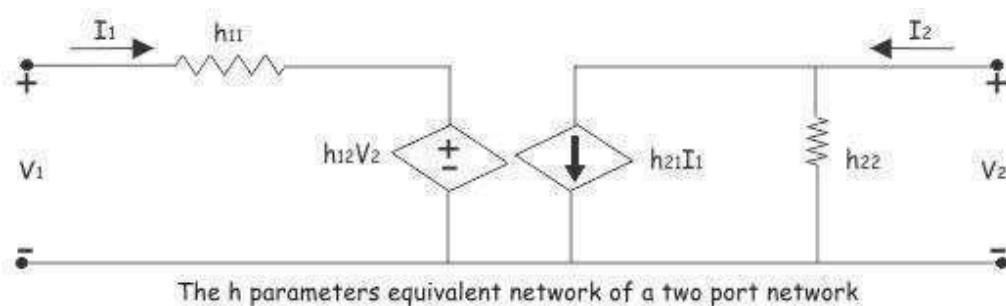

### 6.5 GENERALISED APPROXIMATE MODEL:

In the analysis of transistor amplifier, we have as far used the exact h-model for the transistor. In practice, we may conveniently use an approximately h-model for the transistor which introduces error < 10% in most cases.

This much error may be conveniently tolerated since the h-parameters themselves are not steady but vary considerably for the same type of transistor. We first derive this approximate CE h-model.



Figure 1 gives the equivalent circuit of CE amplifier using exact h-model for CE transistor.

The following steps are used to deriving the approximate h-model:

1. If  $R_L < 0.1 \frac{1}{h_{oe}}$  and  $h_{oe} \cdot R_L < 0.1$ , then we may neglect,  $\frac{1}{h_{oe}}$  being in parallel with  $R_L$ .
2. Having neglected  $h_{oe}$ , the collected current  $I_C$  equals  $h_{fe} \cdot I_b$  and the magnitude of the dependent voltage generator in the emitter circuit is then given by,

$$h_{re} \cdot |V_C| = h_{re} \cdot I_C \cdot R_L \approx h_{re} \cdot h_{fe} \cdot I_b \cdot R_L \dots\dots(1)$$

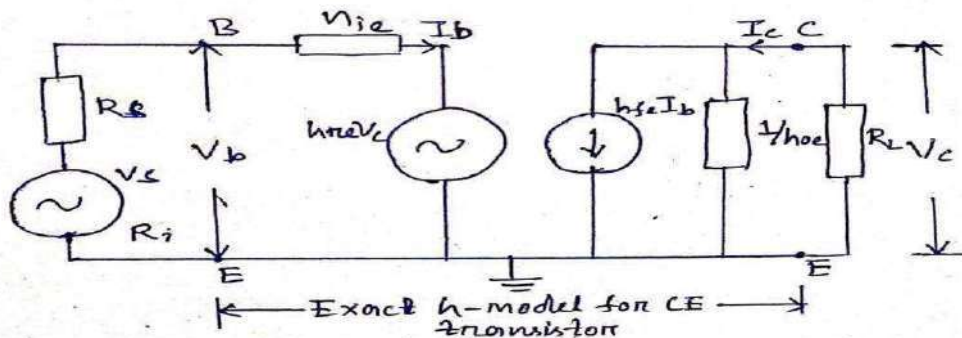

Figure 1: Equivalent circuit using exact h model

But  $h_{re} \cdot h_{fe} \approx 0$ . Hence the voltage  $h_{re} |V_C|$  in the emitter circuit may be neglected in comparison with the voltage drop  $h_{ie} \cdot I_b$  provided that  $R_L$  is not very large. Then the approximate CE h-model reduces to the form shown in Figure 2.

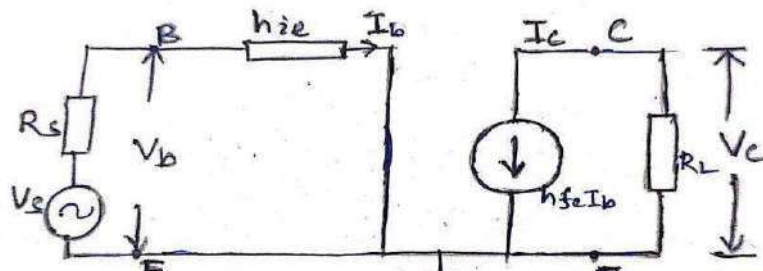

Figure-2: Equivalent circuit using approximate h model of CE amplifier

## 6.6 ANALYSIS OF CB, CE, CC AMPLIFIER USING GENERALISED APPROXIMATE MODEL:

### Approximate h-model Valid for all the three Configuration

The approximate CE h-model of Figure 2 is redrawn in figure 3. This model may be used for any of the three configurations by grounding the appropriate node and analysis done accordingly. It may be proved that the error in values of  $A_i$ ,  $R_i$ ,  $A_v$  or output terminal resistance  $R_{ot} (= R_o \parallel R_L)$  caused by use of approximate model does not exceed 10% if  $h_{oe} \cdot R_L < 0.1$ .

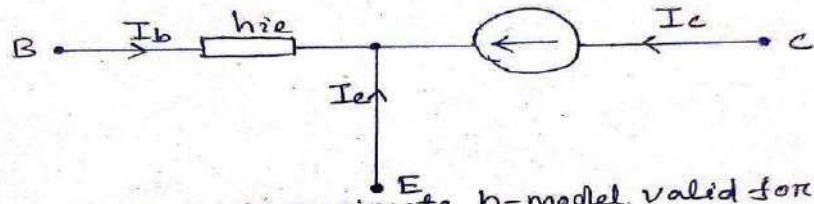

Figure 3: Approximate h-model valid for all the three configurations of a transistor.

### Analysis of CE Amplifier using approximate h-model

Figure 2 gives the equivalent circuit of CE amplifier using approximate h-model for the transistor. For this equivalent circuit we get,

$$\text{Current gain } A_I = \frac{-h_{fe} \times I_b}{I_b} = -h_{fe} \dots (2)$$

$$\text{Input resistance } R_i = h_{ie}$$

$$\text{Voltage gain } A_V = A_I \times \frac{R_L}{R_i} = \frac{-h_{fe} \times R_L}{h_{ie}} \dots (3)$$

**Output resistance  $R_0$ :** From this approximate equivalent circuit of figure 1(b) with  $V_s = 0$  and with external voltage source connected across the output, we get  $I_b = 0$  and therefore  $I_c = 0$ . Hence output resistance  $R_0 = \infty$ . However, in actual practice,  $R_0$  lies between  $40k\Omega$  and  $80k\Omega$  depending on the value of  $R_s$ .

With load resistance  $R_L = 4k\Omega$  (the maximum practical value), the output terminal resistance  $R_t = R_L \parallel \infty = R_L = 4k\Omega$ .

Condition  $h_{oe} * R_L < 0.1$ . For a typical transistor  $h_{oe} = 25 * 10^{-6} S$ . Hence to meet the condition that,  $h_{|oe|} * R_L < 0.1$ . we must use  $R_L$  less than  $4k\Omega$ .

### Analysis of CB Amplifier using the Approximate Model

From figure 4 gives the equivalent circuit of a CB amplifier using the approximate model for the transistor as given in figure 2 with base grounded, the input applied between emitter and base and output obtained across load resistor  $R_L$  between the collector and the base.

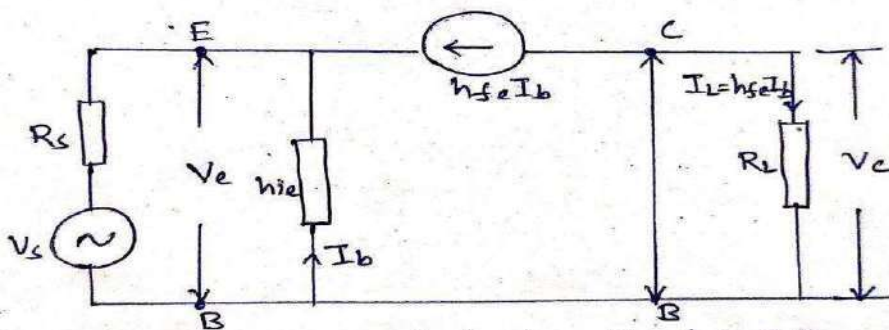

Figure-4: Equivalent circuit of a CB amplifier using approximate h-model

Current gain  $A_I = \frac{I_L}{I_e} = \frac{-h_{fe} \times I_b}{-(1+h_{fe}) \times I_b} = \frac{h_{fe}}{1+h_{fe}} \dots (4)$

**Input resistance  $R_i$ :** from figure 4,

$$V_e = -I_b * h_{ie} \dots (5)$$

$$I_e = -(1 + h_{fe}) * I_b \dots (6)$$

Hence,  $R_i = \frac{V_e}{I_e} = \frac{-I_b \times h_{ie}}{-I_b (1+h_{fe})} = \frac{h_{ie}}{1+h_{fe}} \dots (7)$

**Voltage Gain  $A_v$ :** From figure 4,

$$V_C = -h_{fe} * I_b * R_L$$

Hence,  $A_V = \frac{V_C}{V_e} = \frac{-h_{fe} \times I_b \times R_L}{-I_b \times h_{ie}} = \frac{h_{fe} \times R_L}{h_{ie}} \dots (8)$

Output resistance in the equivalent circuit of figure 3, with  $V_s = 0$ , we get  $I_e = 0$ . Hence,  $I_b = 0$ . Hence the output resistance  $R_o = \infty$ .

Output Terminal Resistance  $R_{ot} = R_o \parallel R_L = \infty \parallel R_L = R_L \dots (9)$

Analysis of CC Amplifier (Emitter Follower) using approximate h-model

Figure 5 gives the equivalent circuit of an emitter follower using the approximate model as given in figure 3, with collector grounded, input signal applied between the base and the ground and the load impedance  $R_L$  connected between emitter and ground.

**Current gain  $A_I$ :** from the circuit of figure 5,

Load current  $I_L = (1 + h_{fe}) I_b \dots (10)$

Hence Current gain  $A_I = \frac{I_L}{I_b} = (1 + h_{fe}) \dots (11)$

**Input resistance  $R_i$ :** from figure 5,

$$V_b = I_b \times h_{ie} + (1 + h_{fe}) I_b \times R_L \dots (12)$$

Hence,  $R_i = \frac{V_b}{I_b} = h_{ie} + (1 + h_{fe}) R_L \dots (13)$

**Voltage Gain  $A_v$ :** From figure 5,

$$V_e = (1 + h_{fe}) I_b * R_L \dots (14)$$

Hence,

$$A_V = \frac{V_e}{V_b} = \frac{(1+h_{fe}) I_b \times R_L}{I_b \times h_{ie} + (1+h_{fe}) I_b \times R_L}$$

$$= \frac{(1+h_{fe})R_L}{h_{ie}+(1+h_{fe})R_L} = 1 - \frac{h_{ie}}{h_{ie}+(1+h_{fe})R_L} = 1 - \frac{h_{ie}}{R_i}$$

Output Resistance from figure 5, Open circuit output voltage =  $V_s$

Short circuit output current

$$I = (1+h_{fe})I_b = \frac{(1+h_{fe})V_s}{h_{ie}+R_s}$$

Hence output impedance

$$R_0 = \frac{\text{Open circuit output voltage}}{\text{Short circuit output current}} = \frac{h_{ie} + R_s}{1 + h_{fe}}$$

Output terminal Impedance  $R_{ot} = R_0 \parallel R_L$

Expressions for current gain etc. for the three configurations using approximate h-model.

Expressions for $A_i$ , $R_i$ , $A_v$ , $R_0$ and $R_{ot}$ using Approximate h-model			
Quantity	CE	CB	CC
$A_i$	$-h_{fe}$	$\frac{h_{fe}}{1+h_{fe}}$	$1+h_{fe}$
$R_i$	$h_{ie}$	$\frac{h_{ie}}{1+h_{fe}}$	$h_{ie} + (1+h_{fe})R_L$
$A_v$	$\frac{h_{fe} \times R_L}{h_{ie}}$	$\frac{h_{fe} \times R_L}{R_e}$	$1 - \frac{h_{ie}}{R_i}$
$R_0$	$\infty$	$\infty$	$\frac{h_{ie} + R_s}{1+h_{fe}}$
$R_{ot}$	$R_L$	$R_L$	$R_0 \parallel R_L$

## 6.7 MULTISTAGE TRANSISTOR AMPLIFIERS:

In Multi-stage amplifiers, the output of first stage is coupled to the input of next stage using a coupling device. The following figure shows a two-stage amplifier connected in cascade.



If there are  $n$  numbers of stages, the product of voltage gains of those  $n$  stages will be the overall gain of that multistage amplifier circuit.

### COUPLING:-

Coupling is a process in which the output of one stage is fed as input to the next stage. The main purpose of coupling is to:-

- 1) Transfer output of one stage to the input of next stage.
- 2) Isolate the dc condition of one stage from the next stage.

### TYPES OF COUPLING:

Coupling is classified into three types. They are:-

- RC coupling
- Transformer coupling
- Direct coupling

### 6.7.1 RC COUPLED TRANSISTOR AMPLIFIER:-

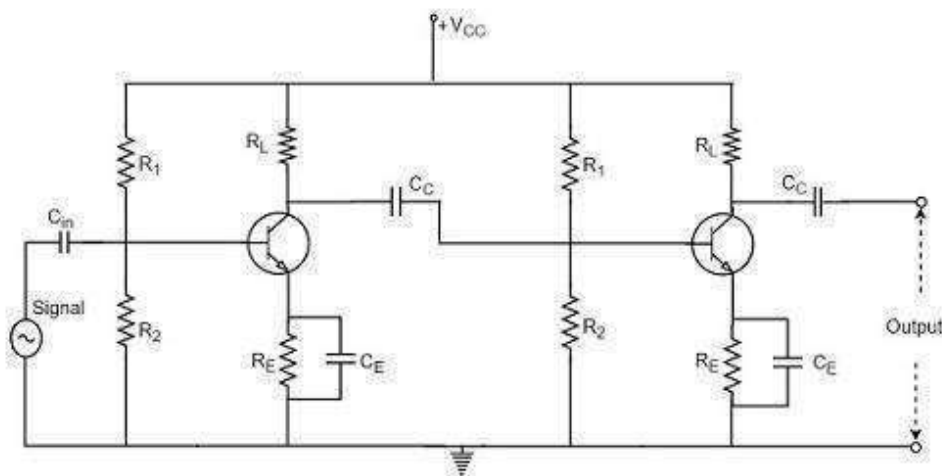

#### Operation of RC Coupled Amplifier

When an AC input signal is applied to the base of first transistor, it gets amplified and appears at the collector load  $R_L$  which is then passed through the coupling capacitor  $C_C$  to the next stage. This becomes the input of the next stage, whose amplified output again appears across its collector load. Thus the signal is amplified in stage by stage action.

#### Frequency Response of RC Coupled Amplifier

Frequency response curve is a graph that indicates the relationship between voltage gain and function of frequency. The frequency response of a RC coupled amplifier is as shown in the following graph.

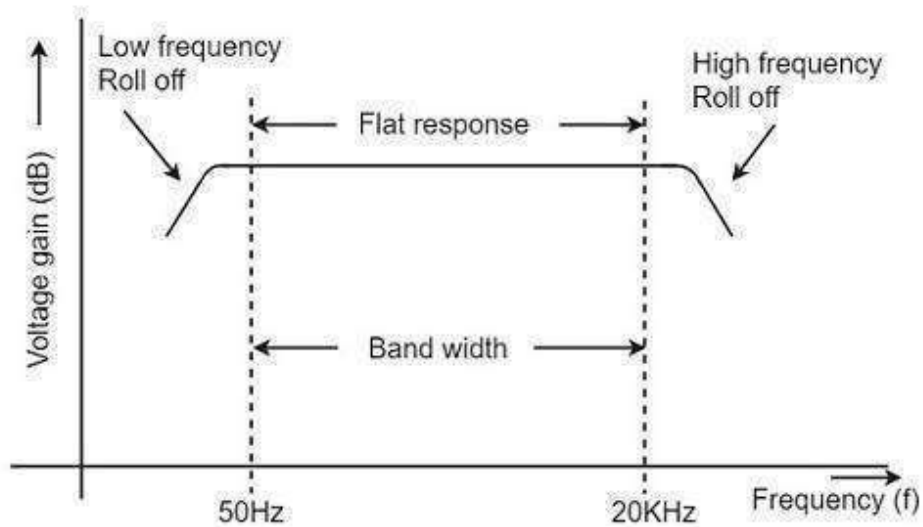

From the above graph, it is understood that the frequency rolls off or decreases for the frequencies below 50Hz and for the frequencies above 20 KHz. whereas the voltage gain for the range of frequencies between 50Hz and 20 KHz is constant.

We know that,

$$X_C = 1/2\pi fc$$

It means that the capacitive reactance is inversely proportional to the frequency.

### **At Low frequencies (i.e. below 50 Hz)**

The capacitive reactance is inversely proportional to the frequency. At low frequencies, the reactance is quite high. The reactance of input capacitor  $C_{in}$  and the coupling capacitor  $C_C$  are so high that only small part of the input signal is allowed. The reactance of the emitter by pass capacitor  $C_E$  is also very high during low frequencies. Hence it cannot shunt the emitter resistance effectively. With all these factors, the voltage gain rolls off at low frequencies.

### **At High frequencies (i.e. above 20 KHz)**

Again considering the same point, we know that the capacitive reactance is low at high frequencies. So, a capacitor behaves as a short circuit, at high frequencies. As a result of this, the loading effect of the next stage increases, which reduces the voltage gain. Along with this, as the capacitance of emitter diode decreases, it increases the base current of the transistor due to which the current gain ( $\beta$ ) reduces. Hence the voltage gain rolls off at high frequencies.

### **At Mid-frequencies (i.e. 50 Hz to 20 KHz)**

The voltage gain of the capacitors is maintained constant in this range of frequencies, as shown in figure. If the frequency increases, the reactance of the capacitor  $C_c$  decreases which tends to increase the gain. But this lower capacitance reactive increases the loading effect of the next stage by which there is a reduction in gain.

Due to these two factors, the gain is maintained constant.

### **Advantages of RC Coupled Amplifier**

The following are the advantages of RC coupled amplifier.

- The frequency response of RC amplifier provides constant gain over a wide frequency range, hence most suitable for audio applications.
- The circuit is simple and has lower cost because it employs resistors and capacitors which are cheap.
- It becomes more compact with the upgrading technology.

### **Disadvantages of RC Coupled Amplifier**

The following are the disadvantages of RC coupled amplifier.

- The voltage and power gain are low because of the effective load resistance.
- They become noisy with age.
- Due to poor impedance matching, power transfer will be low.

### **6.7.2 TRANSFORMER COUPLED AMPLIFIER:-**

In a transformer-coupled amplifier, the stages of amplifier are coupled using a transformer. Let us go into the constructional and operational details of a transformer coupled amplifier.

The figure below shows the circuit diagram of transformer coupled amplifier.

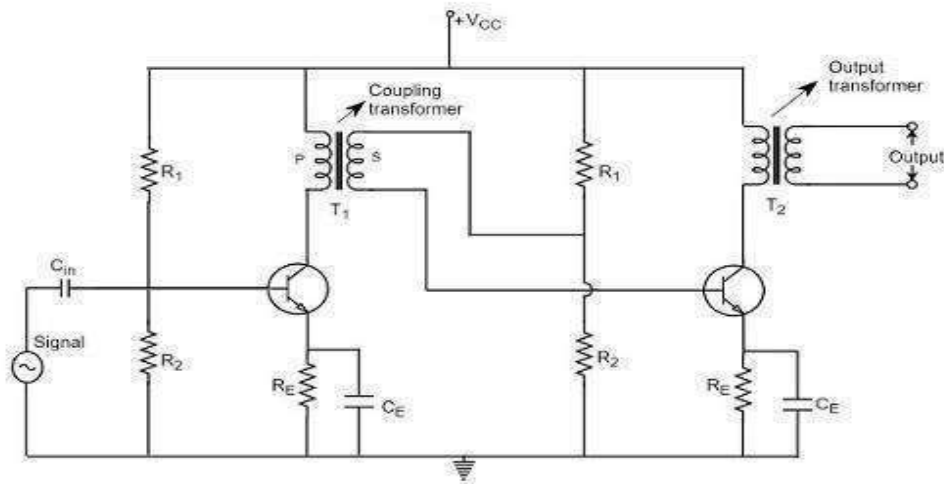

### Operation of Transformer Coupled Amplifier

When an AC signal is applied to the input of the base of the first transistor then it gets amplified by the transistor and appears at the collector to which the primary of the transformer is connected.

The transformer which is used as a coupling device in this circuit has the property of impedance changing, which means the low resistance of a stage (or load) can be reflected as a high load resistance to the previous stage. Hence the voltage at the primary is transferred according to the turns ratio of the secondary winding of the transformer.

This transformer coupling provides good impedance matching between the stages of amplifier. The transformer coupled amplifier is generally used for power amplification.

### Frequency Response of Transformer Coupled Amplifier

The figure below shows the frequency response of a transformer coupled amplifier. The gain of the amplifier is constant only for a small range of frequencies. The output voltage is equal to the collector current multiplied by the reactance of primary.

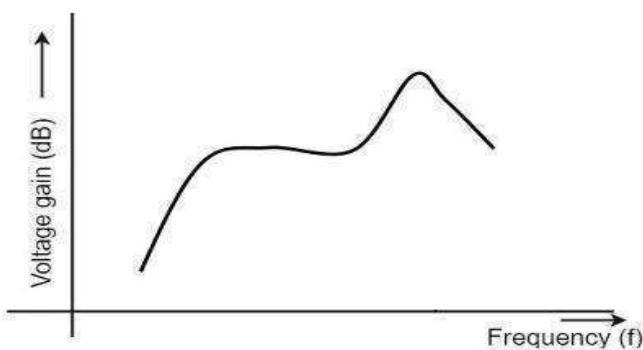



At low frequencies, the reactance of primary begins to fall, resulting in decreased gain. At high frequencies, the capacitance between turns of windings acts as a bypass condenser to reduce the output voltage and hence gain.

So, the amplification of audio signals will not be proportionate and some distortion will also get introduced, which is called as Frequency distortion.

### **Advantages of Transformer Coupled Amplifier**

The following are the advantages of a transformer coupled amplifier –

- An excellent impedance matching is provided.
- Gain achieved is higher.
- There will be no power loss in collector and base resistors.
- Efficient in operation.

### **Disadvantages of Transformer Coupled Amplifier**

The following are the disadvantages of a transformer coupled amplifier –

- Though the gain is high, it varies considerably with frequency. Hence a poor frequency response.
- Frequency distortion is higher.
- Transformers tend to produce hum noise.
- Transformers are bulky and costly.

## **6.8 FEEDBACK IN AMPLIFIER:**

Feedback is the process by which a fraction of the output signal, either a voltage or a current, is used as an input.

### **6.8.1 GENERAL THEORY OF FEEDBACK:**

The process of injecting a fraction of output energy of some device back to the input is known as Feedback. It has been found that feedback is very useful in reducing noise and making the amplifier operation stable.

Depending upon whether the feedback signal aids or opposes the input signal, there are two types of feedbacks used.

#### a) Positive Feedback

The feedback in which the feedback energy i.e., either voltage or current is in phase with the input signal and thus aids it is called as Positive feedback.

Both the input signal and feedback signal introduces a phase shift of  $180^\circ$  thus making a  $360^\circ$  resultant phase shift around the loop, to be finally in phase with the input signal.

Though the positive feedback increases the gain of the amplifier, it has the disadvantages such as

- Increasing distortion
- Instability

It is because of these disadvantages the positive feedback is not recommended for the amplifiers. If the positive feedback is sufficiently large, it leads to oscillations, by which oscillator circuits are formed. This concept will be discussed in OSCILLATORS tutorial.

#### b) Negative Feedback

The feedback in which the feedback energy i.e., either voltage or current is out of phase with the input and thus opposes it, is called as negative feedback.

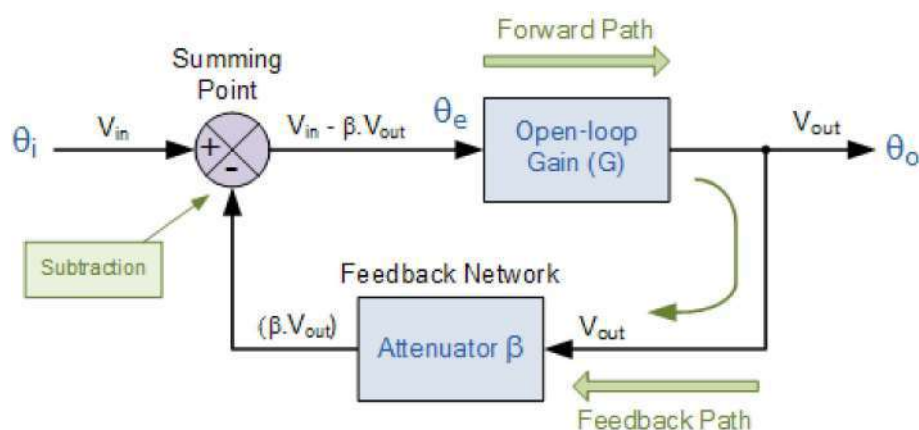

In negative feedback, the amplifier introduces a phase shift of  $180^\circ$  into the circuit while the feedback network is so designed that it produces no phase shift or zero phase shift. Thus the resultant feedback voltage  $V_f$  is  $180^\circ$  out of phase with the input signal  $V_{in}$ .

Though the gain of negative feedback amplifier is reduced, there are many advantages of negative feedback such as

- Stability of gain is improved
- Reduction in distortion
- Reduction in noise
- Increase in input impedance
- Decrease in output impedance
- Increase in the range of uniform application

It is because of these advantages negative feedback is frequently employed in amplifiers.

### 6.8.2 NEGATIVE FEEDBACK CIRCUIT:

A feedback amplifier generally consists of two parts. They are the amplifier and the feedback circuit. The feedback circuit usually consists of resistors. The concept of feedback amplifier can be understood from the following figure.

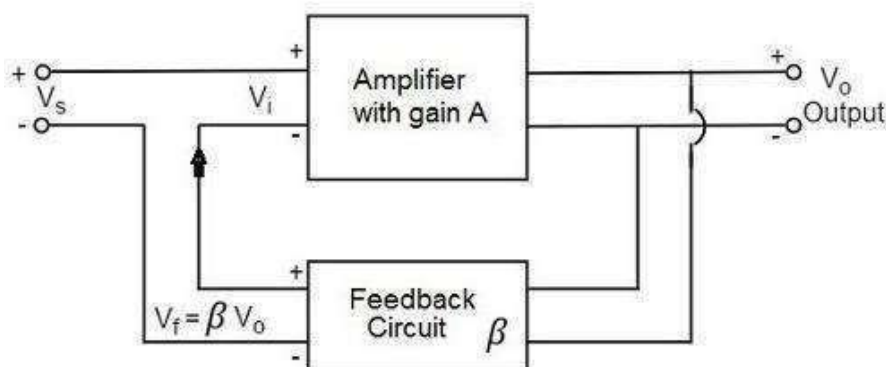

From the above figure, the gain of the amplifier is represented as  $A$ . the gain of the amplifier is the ratio of output voltage  $V_o$  to the input voltage  $V_i$ . the feedback network extracts a voltage  $V_f = \beta V_o$  from the output  $V_o$  of the amplifier.

This voltage is added for positive feedback and subtracted for negative feedback, from the signal voltage  $V_s$ . Now,

$$V_i = V_s + V_f = V_s + \beta V_o$$

$$V_i = V_s - V_f = V_s - \beta V_o$$

The quantity  $\beta = V_f/V_o$  is called as feedback ratio or feedback fraction.

Let us consider the case of negative feedback. The output  $V_o$  must be equal to the input voltage  $(V_s - \beta V_o)$  multiplied by the gain  $A$  of the amplifier.

Hence,  $(V_s - \beta V_o) A = V_o$

Or  $AV_s - A\beta V_o = V_o$

Or  $AV_s = V_o(1 + A\beta)$

Therefore,  $\frac{V_o}{V_s} = \frac{A}{1 + A\beta}$

Let  $A_f$  be the overall gain (gain with the feedback) of the amplifier. This is defined as the ratio of output voltage  $V_o$  to the applied signal voltage  $V_s$ , i.e.

$$A_f = \frac{\text{Output voltage}}{\text{Input signal Voltage}} = \frac{V_o}{V_s}$$

So, from the above two equations, we can understand that.

The equation of gain of the feedback amplifier, with negative feedback is given by

$$A_f = \frac{A}{1 + A\beta}$$

The equation of gain of the feedback amplifier, with positive feedback is given by

$$A_f = \frac{A}{1 - A\beta}$$

These are the standard equations to calculate the gain of feedback amplifiers.

### **6.8.3 ADVANTAGES OF NEGATIVE FEEDBACK AMPLIFIER:**

There are some advantages of negative feedback amplifier which are given below,

- The negative feedback reduces noise.
- It has highly stabilized gain.
- It can control step response of amplifier.
- It has less harmonic distortion.
- It has less amplitude distortion.
- It has less phase distortion.
- Input and output impedances can be modified as desired.
- It can increase or decrease output impedances.
- It has higher fidelity i.e. more linear operation.
- It has less frequency distortion.

There are some disadvantages of negative feedback amplifier which are given below,

- It Increase output resistance in case of current shunt and current series feedback amplifiers.
- Reduction in gain.

### **6.9 POWER AMPLIFIERS AND ITS CLASSIFICATION:**

A power amplifier receives a signal from some pick-up transducer or other input source and provides a large version of the signal to some output device or to another amplifier stage.

On the basic of the amount of the output signal varying over one cycle of operation for a full cycle of input signal, large signal or power amplifiers are classified into five types. They are:-

#### **i) CLASS A POWER AMPLIFIER:**

For Class A Power amplifier the output signal varies for a full 360° of the cycle.

#### **ii) CLASS B POWER AMPLIFIERS:**

For Class B Power amplifier the output signal varies for 180° of the input signal.

iii) CLASS AB POWER AMPLIFIERS:

For class AB power amplifier, the output signal varies between  $180^\circ$  and  $360^\circ$ . It is neither a class A nor a class B amplifier.

iv) CLASS C POWER AMPLIFIERS:

For Class C Power amplifier the collector current flows for less than half cycle of the input signal.

v) CLASS D POWER AMPLIFIERS:

Class D Power amplifiers remain ON for a short interval and OFF for a long interval.

**6.9.1 DIFFERENCE BETWEEN VOLTAGE AND POWER AMPLIFIER:**

<b>BASIS OF COMPARISON</b>	<b>VOLTAGE</b>	<b>POWER AMPLIFIER</b>
<b>Use</b>	The voltage amplifier amplifies the voltage or increases the voltage level of a signal.	The power amplifier amplifies the power of a signal.
<b>Functionality</b>	The voltage amplifier can work with low magnitude signal.	The voltage amplifier can work with low magnitude signal.
<b>Amplitude Of AC Signal</b>	In voltage amplifier, the amplitude of input A.C signal is small.	In power amplifier the amplitude of input A.C signal is large.
<b>Transistor</b>	The transistor used in the voltage amplifier has a thin base because it does not handle large current.	The transistor used in the power amplifier has a thick base because it handles the very large current.
<b>Output Impedance</b>	The output impedance of the voltage amplifier is very high, about 12 kilo-ohm.	The output impedance of the power amplifier is very low, up to 200 ohm, so that it can deliver a high current.
<b>Collector Current</b>	The collector current of the voltage amplifier is very low up to 1 mA.	The collector current of the power amplifier is high greater than 100 mA.
<b>Transistor Heat Dissipation</b>	The transistor used can dissipate less heat produced during its operation.	The transistor used can dissipate more heat produced as compared to voltage amplifier during its operation.
<b>Size Of Transistor</b>	The physical size of transistor used is usually	The physical size of transistor used is usually large and is

	small and is known as low or medium power transistor.	known as power transistor.
<b>Collector Load</b>	In power amplifier, the collector load has low resistance, typically $5\Omega$ to $20\Omega$ .	In voltage amplifier, the collector load has high resistance, typically $4\Omega$ to $10k\Omega$ .
<b>Coupling</b>	RC coupling is used in voltage amplifier.	Transformer coupling is used in power amplifier.
<b>Application</b>	Voltage amplifier is used for small signal voltage.	Power amplifier is used for high voltage signals.
<b>Current Gain</b>	The current gain of the power amplifier is very high.	The current gain of the power amplifier is very high.

### 6.9.2 TRANSFORMER COUPLED CLASS A POWER AMPLIFIER:

The class A power amplifier as discussed in the previous chapter, is the circuit in which the output current flows for the entire cycle of the AC input supply. We also have learnt about the disadvantages it has such as low output power and efficiency. In order to minimize those effects, the transformer coupled class A power amplifier has been introduced.

The **construction of class A power amplifier** can be understood with the help of below figure. This is similar to the normal amplifier circuit but connected with a transformer in the collector load.

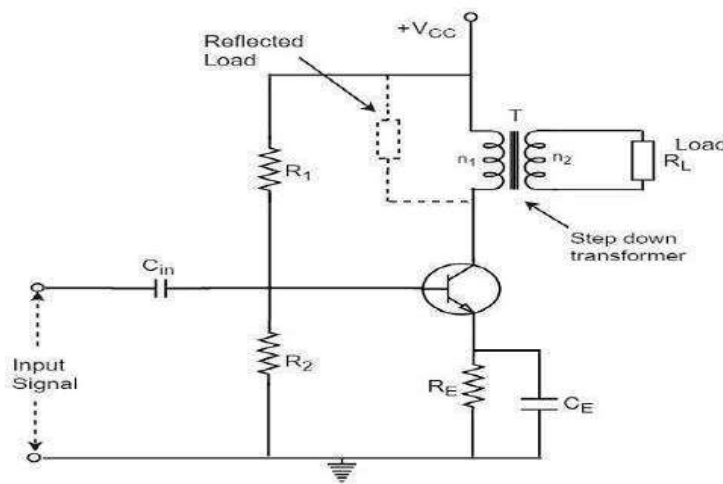

Here  $R_1$  and  $R_2$  provide potential divider arrangement. The resistor  $R_e$  provides stabilization,  $C_e$  is the bypass capacitor and  $R_e$  to prevent a.c. voltage. The transformer used here is a step-down transformer.

The high impedance primary of the transformer is connected to the high impedance collector circuit. The low impedance secondary is connected to the load (generally loud speaker).

Transformer Action

The transformer used in the collector circuit is for impedance matching.  $R_L$  is the load connected in the secondary of a transformer.  $R_L'$  is the reflected load in the primary of the transformer.

The number of turns in the primary are  $n_1$  and the secondary are  $n_2$ . Let  $V_1$  and  $V_2$  be the primary and secondary voltages and  $I_1$  and  $I_2$  be the primary and secondary currents respectively. The below figure shows the transformer clearly.

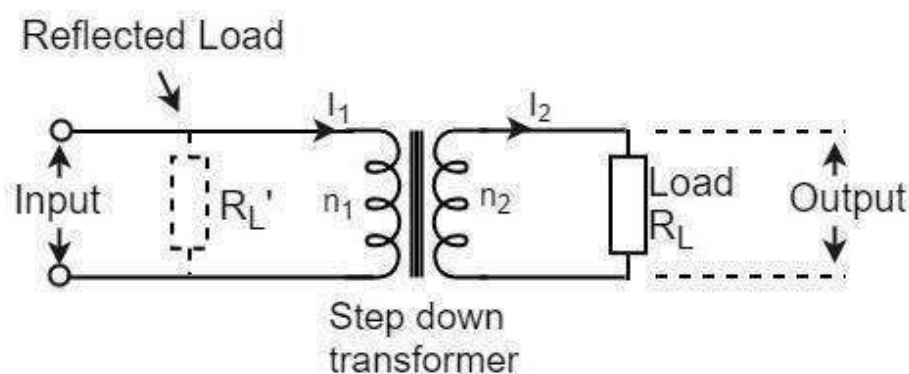

We know that

$$\frac{v_1}{v_2} = \frac{n_1}{n_2} \text{ and } \frac{I_1}{I_2} = \frac{n_2}{n_1}$$

Or

$$V_1 = \frac{n_1}{n_2} V_2 \text{ and } I_1 = \frac{n_2}{n_1} I_2$$

Hence

$$\frac{V_1}{I_1} = \left(\frac{n_1}{n_2}\right)^2 \frac{V_2}{I_2}$$

But  $V_1/I_1 = R_L' =$  effective input resistance

And  $V_2/I_2 = R_L =$  effective output resistance

Therefore,

$$R_L' = \left(\frac{n_1}{n_2}\right)^2 R_L = n^2 R_L$$

Where

$$n = \frac{\text{number of turns in primary}}{\text{number of turns in secondary}} = \frac{n_1}{n_2}$$

A power amplifier may be matched by taking proper turn ratio in step down transformer.

**Circuit Operation**

If the peak value of the collector current due to signal is equal to zero signal collector current, then the maximum a.c. power output is obtained. So, in order to

achieve complete amplification, the operating point should lie at the center of the load line.

The operating point obviously varies when the signal is applied. The collector voltage varies in opposite phase to the collector current. The variation of collector voltage appears across the primary of the transformer.

### Circuit Analysis

The power loss in the primary is assumed to be negligible, as its resistance is very small.

The input power under dc condition will be

$$(P_{in})_{dc} = (P_{tr})_{dc} = V_{CC} * (I_C)_Q$$

Under maximum capacity of class A amplifier, voltage swings from  $(V_{ce})_{max}$  to zero and current from  $(I_C)_{max}$  to zero.

Hence

$$V_{rms} = \frac{1}{\sqrt{2}} \left[ \frac{(V_{ce})_{max} - (V_{ce})_{min}}{2} \right] = \frac{1}{\sqrt{2}} \left[ \frac{(V_{ce})_{max}}{2} \right] = \frac{2V_{CC}}{2\sqrt{2}} = \frac{V_{CC}}{\sqrt{2}}$$

$$I_{rms} = \frac{1}{\sqrt{2}} \left[ \frac{(I_C)_{max} - (I_C)_{min}}{2} \right] = \frac{1}{\sqrt{2}} \left[ \frac{(I_C)_{max}}{2} \right] = \frac{2(I_C)_Q}{2\sqrt{2}} = \frac{(I_C)_Q}{\sqrt{2}}$$

Therefore,

$$(P_o)_{ac} = V_{rms} * I_{rms} = \frac{V_{CC}}{\sqrt{2}} * \frac{(I_C)_Q}{\sqrt{2}} = \frac{V_{CC} * (I_C)_Q}{2}$$

Therefore,

$$\text{Collector Efficiency} = \frac{(P_o)_{ac}}{(P_{tr})_{dc}}$$

Or,

$$\begin{aligned} (\eta)_{collector} &= \frac{V_{CC} * (I_C)_Q}{2 * V_{CC} * (I_C)_Q} = \frac{1}{2} \\ &= \frac{1}{2} * 100 = 50\% \end{aligned}$$

The efficiency of a class A power amplifier is nearly than 30% whereas it has got improved to 50% by using the transformer coupled class A power amplifier.

### Advantages

The advantages of transformer coupled class A power amplifier are as follows.

- No loss of signal power in the base or collector resistors.
- Excellent impedance matching is achieved.
- Gain is high.



- DC isolation is provided.

### Disadvantages

The disadvantages of transformer coupled class A power amplifier are as follows.

- Low frequency signals are less amplified comparatively.
- Hum noise is introduced by transformers.
- Transformers are bulky and costly.
- Poor frequency response.

### Applications

The applications of transformer coupled class A power amplifier are as follows.

- This circuit is where impedance matching is the main criterion.
- These are used as driver amplifiers and sometimes as output amplifiers.

### 6.9.3 CLASS A PUSH PULL AMPLIFIER:-

- ✓ Class A push pull amplifier uses two complementary transistors in the output stage with one transistor being an NPN or N-channel type while the other transistor is a PNP or P-channel (the complement) type connected in order to operate them like PUSH a transistor to ON and PULL another transistor to OFF at the same time.
- ✓ This push-pull configuration can be made in class A, class B, class C or class AB amplifiers.

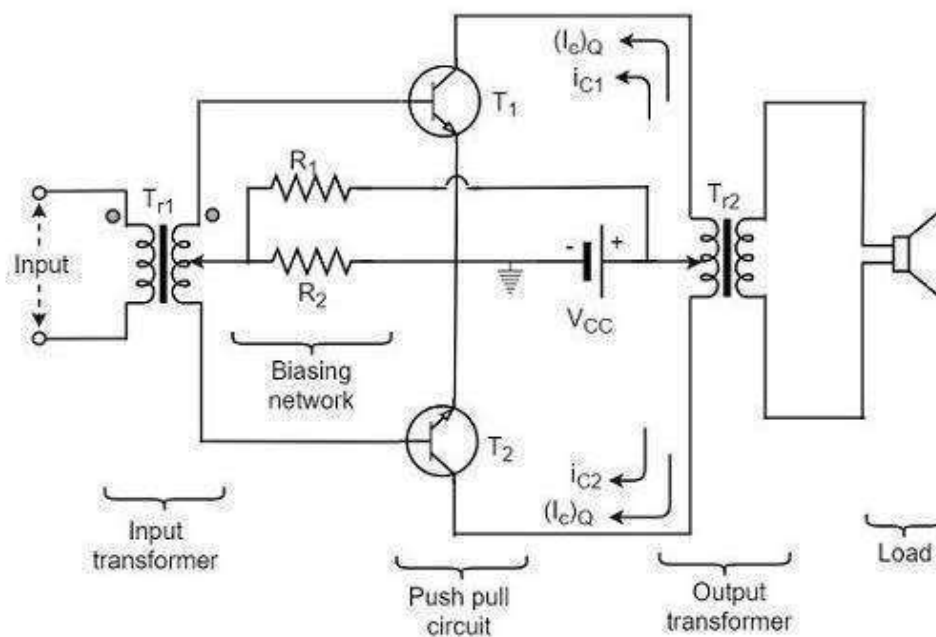

## Circuit Operation

The output is collected from the output transformer  $T_{r2}$ . The primary of this transformer  $T_{r2}$  has practically no dc component through it. The transistors  $T_1$  and  $T_2$  have their collectors connected to the primary of transformer  $T_{r2}$  so that their currents are equal in magnitude and flow in opposite directions through the primary of transformer  $T_{r2}$ .

When the a.c. input signal is applied, the base of transistor  $T_1$  is more positive while the base of transistor  $T_2$  is less positive. Hence the collector current  $i_{c1}$  of transistor  $T_1$  increases while the collector current  $i_{c2}$  of transistor  $T_2$  decreases. These currents flow in opposite directions in two halves of the primary of output transformer. Moreover, the flux produced by these currents will also be in opposite directions.

Hence, the voltage across the load will be induced voltage whose magnitude will be proportional to the difference of collector currents i.e.

$$(i_{c1} - i_{c2})$$

Similarly, for the negative input signal, the collector current  $i_{c2}$  will be more than  $i_{c1}$ . In this case, the voltage developed across the load will again be due to the difference

$$(i_{c1} - i_{c2})$$

$$\text{As } i_{c2} > i_{c1}$$

The polarity of voltage induced across load will be reversed.

$$i_{c1} - i_{c2} = i_{c1} + (-i_{c2})$$

To have a better understanding, let us consider the below figure.

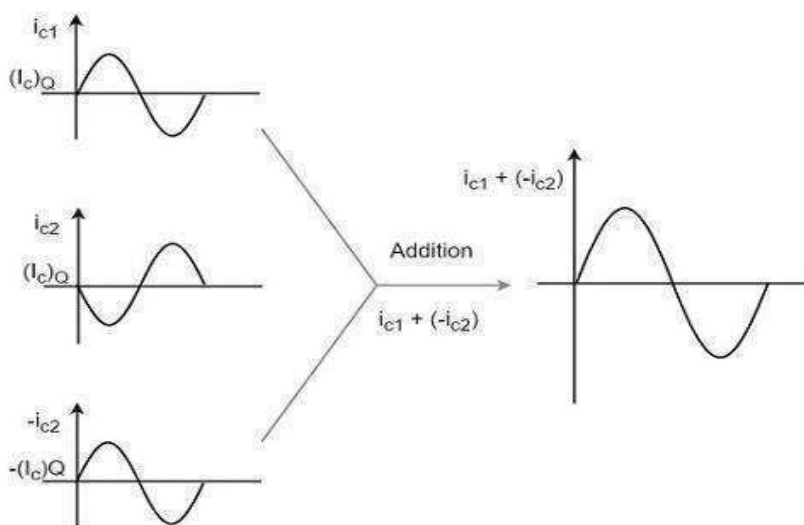

The overall operation results in an a.c. voltage induced in the secondary of output transformer and hence a.c. power is delivered to that load.

## Advantages

The advantages of class A Push-pull amplifier are as follows

- High a.c. output is obtained.
- The output is free from even harmonics.
- The effects of ripple voltages are balanced out. These are present in the power supply due to inadequate filtering.

## Disadvantages

The disadvantages of class A Push-pull amplifier are as follows

- The transistors are to be identical, to produce equal amplification.
- Center-tapping is required for the transformers.
- The transformers are bulky and costly.

### 6.9.4 CLASS B PUSH PULL AMPLIFIER:-

Though the efficiency of class B power amplifier is higher than class A, as only one half cycle of the input is used, the distortion is high. Also, the input power is not completely utilized. In order to compensate these problems, the push-pull configuration is introduced in class B amplifier.

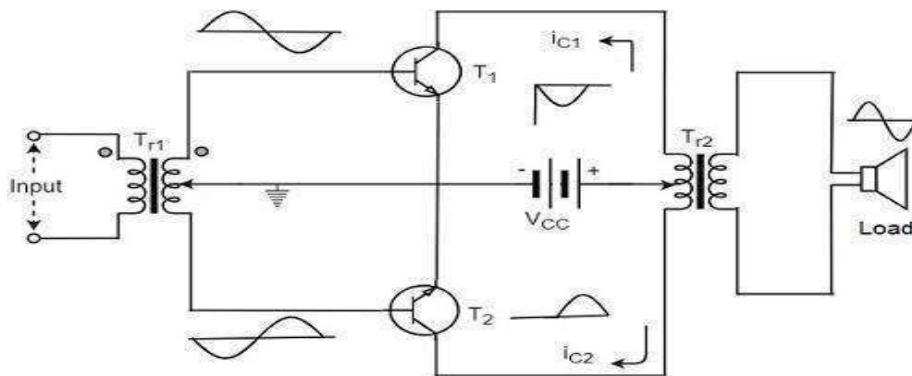

The circuit operation of class B push pull amplifier is given below.

### Operation

The circuit of class B push-pull amplifier shown in the above figure clears that both the transformers are center-tapped. When no signal is applied at the input, the transistors  $T_1$  and  $T_2$  are in cut off condition and hence no collector currents flow. As no current is drawn from  $V_{CC}$ , no power is wasted.

When input signal is given, it is applied to the input transformer  $T_{r1}$  which splits the signal into two signals that are  $180^\circ$  out of phase with each other. These two signals are given to the two identical transistors  $T_1$  and  $T_2$ . For the positive half cycle, the base of the transistor  $T_1$  becomes positive and collector current flows. At the same

time, the transistor  $T_2$  has negative half cycle, which throws the transistor  $T_2$  into cutoff condition and hence no collector current flows. The waveform is produced as shown in the following figure.

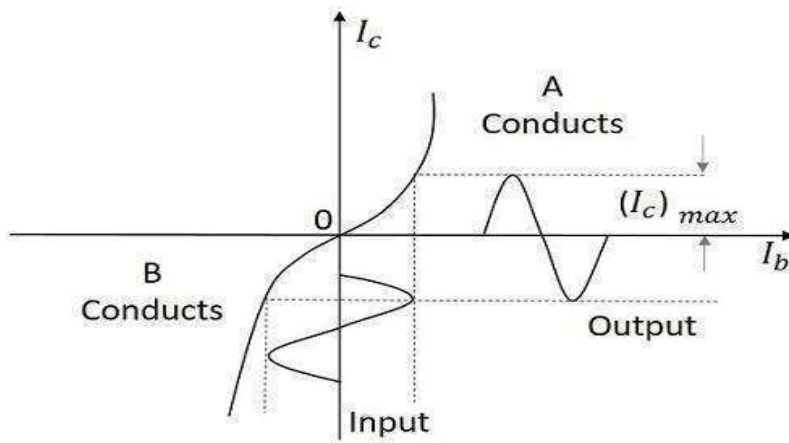

For the next half cycle, the transistor  $T_1$  gets into cut off condition and the transistor  $T_2$  gets into conduction, to contribute the output. Hence for both the cycles, each transistor conducts alternately. The output transformer  $T_{r3}$  serves to join the two currents producing an almost undistorted output waveform.

#### Power Efficiency of Class B Push-Pull Amplifier

The current in each transistor is the average value of half sine loop.

For half sine loop,  $I_{dc}$  is given by

$$I_{dc} = \frac{(I_C)_{max}}{\pi}$$

Therefore,  $(P_{in})_{dc} = 2 \times \left[ \frac{(I_C)_{max}}{\pi} \times V_{CC} \right]$

Here factor 2 is introduced as there are two transistors in push pull amplifier.

R.M.S value of collector current =  $(I_C)_{max} / \sqrt{2}$

R.M.S value of output voltage =  $V_{CC} / \sqrt{2}$

Under ideal conditions of maximum power

Therefore,  $(P_O)_{ac} = \frac{(I_C)_{max}}{\sqrt{2}} \times \frac{V_{CC}}{\sqrt{2}} = \frac{(I_C)_{max} \times V_{CC}}{2}$

Now overall maximum efficiency

$$\begin{aligned} \eta_{overall} &= \frac{(P_O)_{ac}}{(P_{in})_{dc}} \\ &= \frac{(I_C)_{max} \times V_{CC}}{2} \times \frac{\pi}{2(I_C)_{max} \times V_{CC}} \\ &= \frac{\pi}{4} = 0.785 = 78.5\% \end{aligned}$$

The collector efficiency would be the same.

Hence the class B push pull amplifier improves the efficiency than the class A push pull amplifier.

## 6.10 OSCILLATORS

An oscillator is a circuit which produces a continuous, repeated, alternating waveform without any input. Oscillators basically convert unidirectional current flow from a DC source into an alternating waveform which is of the desired frequency, as decided by its circuit components.

The following points may be noted:

1. A transistor amplifier with proper positive feedback will work as an oscillator.
2. The circuit needs only a quick trigger signal to start the oscillations. Once the oscillations have started, no external signal source is needed.
3. In order to get continuous Undamped output from the circuit, the following condition must be met:

$$m_v A_v = 1$$

Where  $m_v$  = voltage gain of amplifier without feedback

$A_v$  = feedback fraction

This relation is called Barkhausen criterion.

### Barkhausen Criterion

Barkhausen criterion is that in order to produce continuous Undamped oscillations at the output of an amplifier, the positive feedback should be such that :

$$m_v A_v = 1$$

Once this condition is set in the positive feedback amplifier, continuous undamped oscillations can be obtained at the output.

### 6.10.1 Different types of Transistor Oscillators

All oscillators under different names have similar function i.e. they produce continuous undamped output. However, the major difference between these oscillators lies in the method by which energy is supplied to the tank circuit to meet the losses.

The following are the transistor oscillators commonly used at various places in electronic circuit:

1. Tuned collector oscillator
2. Colpitt Oscillator
3. Hartley Oscillator
4. Phase shift Oscillator
5. Wien Bridge Oscillator
6. Crystal Oscillator

### 6.10.2 Essentials of Transistor Oscillator

the block diagram of an oscillator is shown below. Its essential components are:

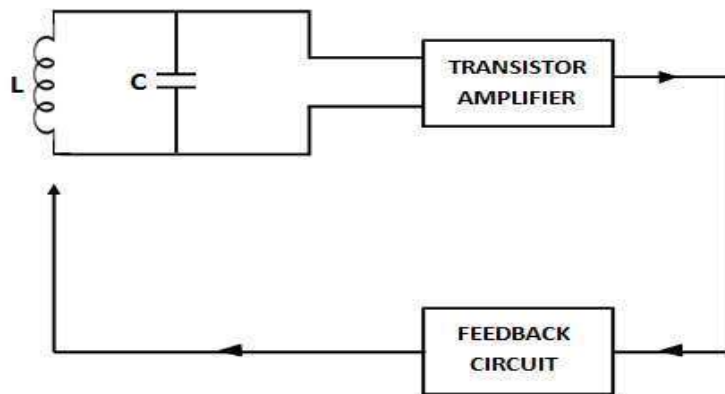

(i) Tank Circuit:

It consists of inductance (L) connected in parallel with capacitor (C). The frequency of oscillations in the circuit depends upon the values L and C.

(ii) Transistor amplifier:

The transistor amplifier receives d.c. power from the battery and changes it into a.c. power for supplying to the tank circuit. The oscillations occurring in the tank circuit are applied to the input of the transistor amplifier. Because of the amplifying nature of the transistor, we get increased output of these oscillations. This amplified output of oscillations is due to the d.c. power supplied by the battery. The output of the transistor can be supplied to the tank circuit to meet the losses.

(iii) Feedback circuit:

The feedback circuit supplies a part of collector energy to the tank circuit in correct phase to aid the oscillations i.e. it provides positive feedback.

### 6.10.3 PRINCIPLE OF OPERATION OF TUNED COLLECTOR, HARTLEY, COLPITT, PHASE SHIFT, WEIN- BRIDGE OSCILLATOR

**TUNED COLLECTOR OSCILLATOR: -**

- ✓ Tuned collector oscillator is the simplest and the basic type of LC oscillators.

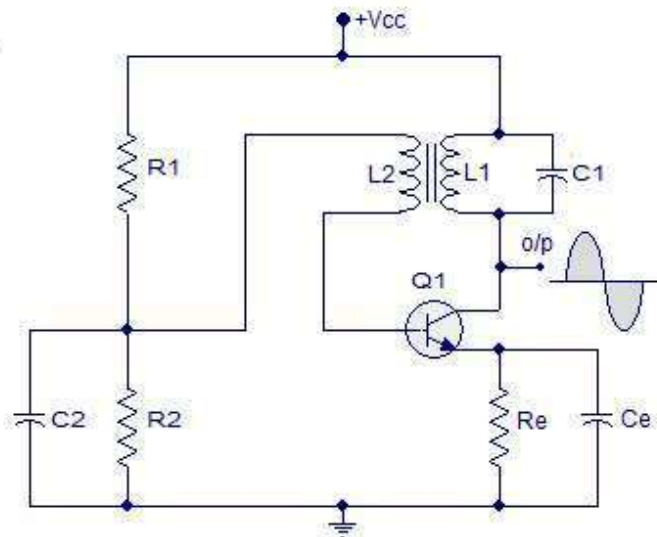

Tuned collector oscillator

### Circuit Operation:

When  $V_{CC}$  is applied to the circuit, collector current starts increasing and charges the capacitor  $C_1$ .

When this capacitor is fully charged, it discharges through coil  $L_1$ , setting up oscillations of frequency determined by  $\exp.(i)$ .

These oscillations induce some voltage in coil  $L_2$  by mutual induction.

The frequency of voltage in coil  $L_2$  is the same as that of tank circuit but its magnitude depends upon the number of turns of  $L_2$  and coupling between  $L_1$  and  $L_2$ .

The voltage across  $L_2$  is applied between base and emitter and appears in the amplified form in the collector circuit, thus overcoming the losses occurring in the tank circuit.

The number of turns of  $L_2$  and coupling between  $L_1$  and  $L_2$  are so adjusted that oscillations across  $L_2$  are amplified to a level just sufficient to supply losses to the tank circuit.

A phase shift of  $180^\circ$  is created between the voltage of  $L_1$  and  $L_2$  due to transformer action. A further phase shift of  $180^\circ$  takes place between base-emitter and collector circuit due to transistor properties. As a result, the energy feedback to the tank circuit is in phase with the generated oscillations.

### WEIN BRIDGE OSCILLATOR:-

- ✓ It is essentially a two-stage amplifier with an R-C bridge circuit.

## Wien Bridge Oscillator Circuit

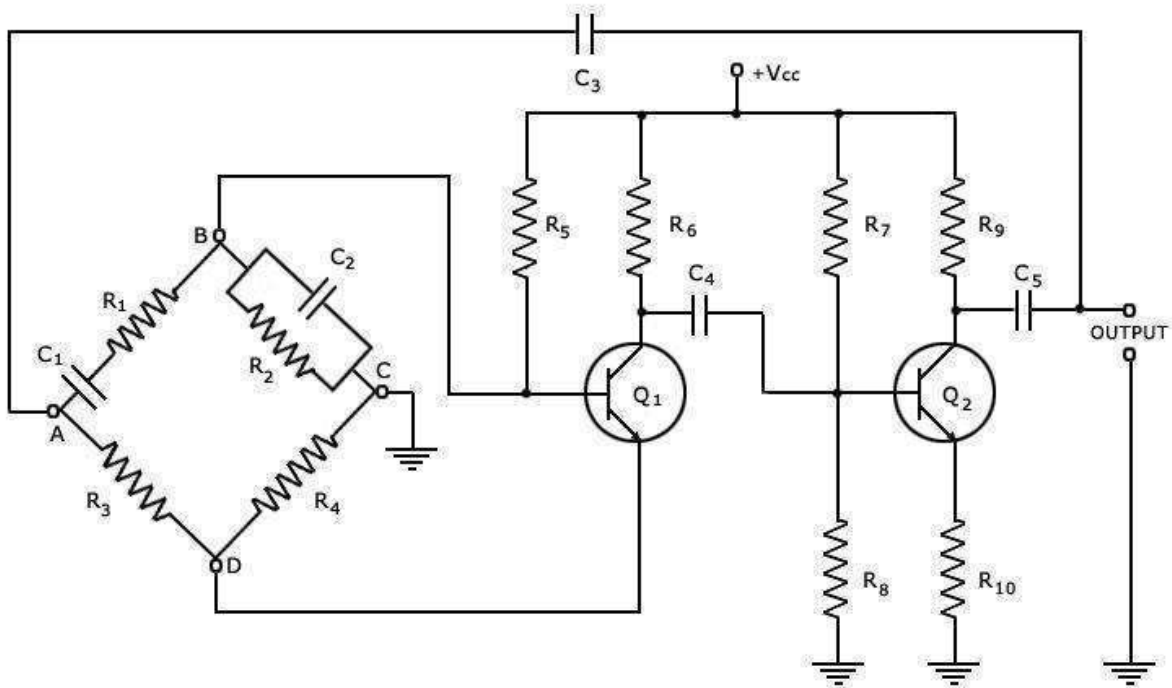

### Wien Bridge Oscillator - Working

- ✓ The circuit is set in oscillation by any random change in base current of transistor  $Q_1$  that may be due to noise inherent in the transistor or variation in voltage of dc supply.
- ✓ This variation in base current is amplified in collector circuit of transistor  $Q_1$  but with a phase-shift of  $180^\circ$ .
- ✓ The output of transistor  $Q_1$  is fed to the base of second transistor  $Q_2$  through capacitor  $C_4$ .
- ✓ Now a still further amplified and twice phase-reversed signal appears at the collector of the transistor  $Q_2$ .
- ✓ Having been inverted twice, the output signal will be in phase with the signal input to the base of transistor  $Q_1$ .
- ✓ The continuous frequency variation in this oscillator can be done by varying the two capacitors  $C_1$  and  $C_2$  simultaneously.
- ✓ These capacitors are variable air-gang capacitors.
- ✓ The advantages and disadvantages of Wien bridge oscillators are given below:

#### Advantages

1. Provides a stable low distortion sinusoidal output over a wide range of frequency.
2. The frequency range can be selected simply by using decade resistance boxes.
3. The frequency of oscillation can be easily varied by varying capacitances  $C_1$  and  $C_2$  simultaneously. The overall gain is high because of two transistors.

#### Disadvantages

1. The circuit needs two transistors and a large number of other components.



2. The maximum frequency output is limited because of amplitude and the phase-shift characteristics of amplifier.

### **HARTLEY OSCILLATOR:-**

- ✓ The Hartley oscillator is an electronic oscillator circuit in which the oscillation frequency is determined by the tuned circuit consisting of capacitors and inductors, that is, an LC oscillator.

### **Hartley Oscillator Circuit and Working**

- ✓ The circuit diagram of a Hartley oscillator is shown in the below figure.

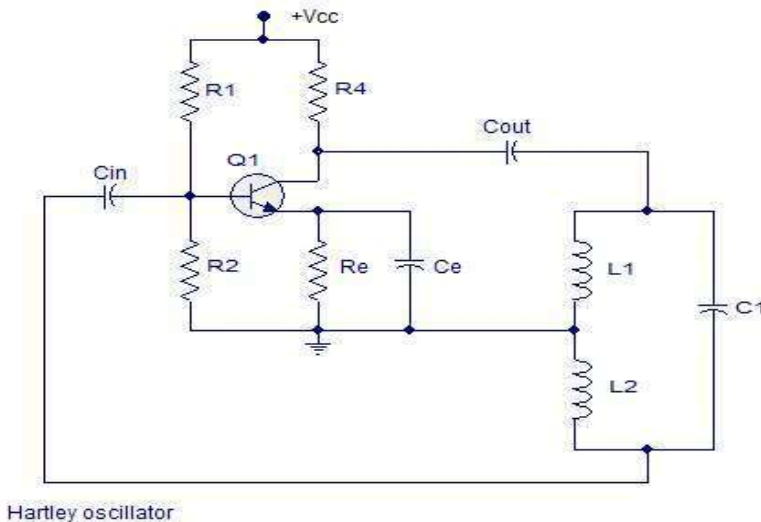

- ✓ When the power supply is switched ON the transistor starts conducting and the collector current increases.
- ✓ As a result the capacitor C1 starts charging and when the capacitor C1 is fully charged it starts discharging through coil L1.
- ✓ This charging and discharging creates a series of damped oscillations in the tank circuit and it is the key.
- ✓ The oscillations produced in the tank circuit is coupled (fed back) to the base of Q1 and it appears in the amplified form across the collector and emitter of the transistor.
- ✓ The output voltage of the transistor (voltage across collector and emitter) will be in phase with the voltage across inductor L1.
- ✓ Since the junction of two inductors is grounded, the voltage across L2 will be  $180^\circ$  out of phase to that of the voltage across L1.
- ✓ The voltage across L2 is actually fed back to the base of Q1.
- ✓ From this we can see that, the feedback voltage is  $180^\circ$  out of phase with the transistor and also the transistor itself will create another  $180^\circ$  phase difference.
- ✓ So the total phase difference between input and output is  $360^\circ$  and it is very important condition for creating sustained oscillations.

- ✓ The frequency of oscillations in this circuit is

$$f_o = 1 / (2\pi \sqrt{L_{eq} C})$$

- ✓ Where  $L_{eq}$  is the total inductance of coils in the tank circuit is given as

$$L_{eq} = L_1 + L_2 + 2M$$

- ✓ For a practical circuit, if  $L_1 = L_2 = L$  and the mutual inductance are neglected, then the frequency of oscillations can be simplified as

$$f_o = 1 / (2\pi \sqrt{2 L C})$$

### COLPITT OSCILLATOR:-

- ✓ Colpitt Oscillator is an electronic oscillator which uses an inductor and capacitors to form an LC oscillator circuit.
- ✓ Colpitt oscillator was invented by American scientist Edwin Colpitt in 1918.
- ✓ The circuit diagram of a typical Colpitt oscillator using transistor is shown in the figure below.

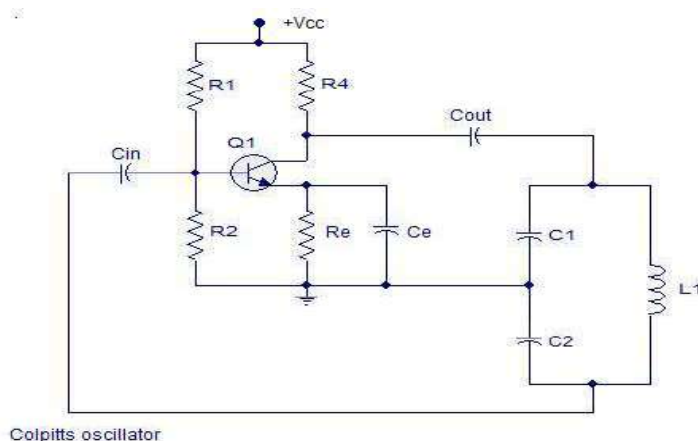

- ✓ When power supply is switched ON, capacitors C1 and C2 starts charging.
- ✓ When they are fully charged they start discharging through the inductor L1.
- ✓ When the capacitors are fully discharged, the electrostatic energy stored in the capacitors gets transferred to the inductor as magnetic flux.
- ✓ The inductor starts discharging and capacitors get charged again.
- ✓ This transfer of energy back and forth between capacitors and inductor is the basis of oscillation.
- ✓ Voltage across C2 is phase opposite to that of the voltage across the C1 and it is the voltage across C2 that is fed back to the transistor.
- ✓ The feedback signal at the base of transistor appears in the amplified form across the collector and emitter of the transistor.

- ✓ The energy lost in the tank circuit is compensated by the transistor and the oscillations are sustained.
- ✓ The tank circuit produces 180° phase shift and the transistor itself produces another 180° phase shift.
- ✓ That means the input and output are in phase and it is a necessary condition of positive feedback for maintaining sustained oscillations.
- ✓ The frequency of oscillations of the Colpitt oscillator can be determined using the equation below.

$$F = \frac{1}{2\pi\sqrt{LC}}$$

Where L is the inductance of the inductor in the tank circuit and C is the effective capacitance of the capacitors in the tank circuit.

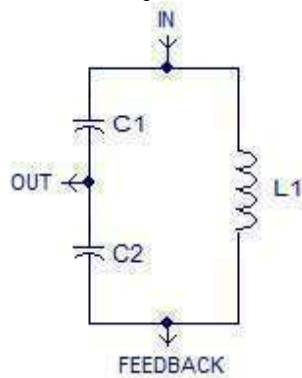

- ✓ If C1 and C2 are the individual capacitance, then the effective capacitance of the serial combination  $C = \frac{C1C2}{C1+C2}$ .
- ✓ By using ganged variable capacitors in place of C1 and C2, the Colpitt oscillator can be made variable.

### **Advantages of Colpitt oscillator**

- ✓ Main advantage of Colpitt oscillator over Hartley oscillator is the improved performance in the high frequency region.
- ✓ This is because the capacitors provide a low reactance path for the high frequency signals and thus the output signals in the high frequency domain will be more sinusoidal.
- ✓ Due to the excellent performance in the high frequency region, the Colpitt oscillator can be even used in microwave applications.

### **PHASE SHIFT OSCILLATOR:**

- ✓ RC phase shift oscillator or simply RC oscillator is a type of oscillator where a simple RC network (resistor-capacitor) network is used for giving the required phase shift to the feedback signal.

- ✓ In LC oscillators like Hartley oscillator and Colpitt oscillator an LC network (inductor- capacitor network) is used for providing the necessary positive feedback.
- ✓ The main feature of an RC phase shift oscillator is the excellent frequency stability.
- ✓ The RC oscillator gives a pure sine wave output on a wide range of loads.

### RC phase shift network.

- ✓ RC phase shift network is a simple resistor capacitor network that can be used to give a desired phase shift to a signal.
- ✓ The circuit diagram of a simple single stage RC network is shown in the figure below.

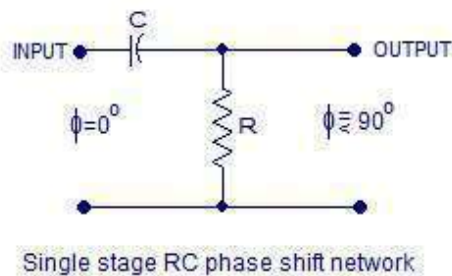

- ✓ Theoretically in a simple RC circuit, the output voltage will lead the input voltage by a phase angle  $\Phi = 90^\circ$ .
- ✓ But in practical case the phase angle will be something below  $90^\circ$  just because it is impossible to get a purely ideal capacitor.
- ✓ Phase shift of a practical RC network depends on the value of the capacitor, resistor and the operating frequency.
- ✓ Let  $F$  be the operating frequency,  
 $R$  be the resistance and  $C$  be the capacitance.
- ✓ Then the capacitive reactance  $X_c$  to the frequency  $F$  can be given by the equation  $X_c = 1 / (2\pi FC)$
- ✓ The effective impedance of the circuit can be given by the equation  $Z = \sqrt{(R^2 + X_c^2)}$
- ✓ The phase angle of the RC network can be derived as  $\Phi = \tan^{-1}(X_c/R)$ .
- ✓ Just by making an RC network with phase shift equal to  $60^\circ$  and cascading three of them together the desired phase shift of  $180^\circ$  can be attained.
- ✓ This  $180^\circ$  phase shift by the RC network plus the  $180^\circ$  phase shift made by the transistor gives a total phase shift of  $360^\circ$  between the input and output which is the necessary condition for maintaining sustained oscillations.
- ✓ The circuit diagram of a three stage RC network producing a phase shift of  $180^\circ$  is shown in the figure below.

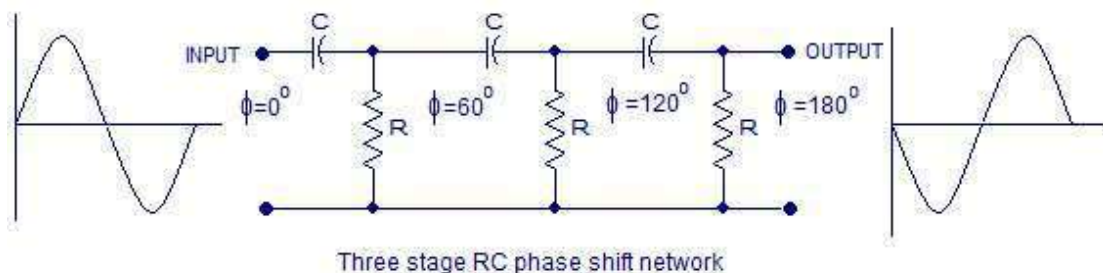

- ✓ Connecting such a three stage RC phase shift network between the input and output of a common emitter transistor amplifier will result in a transistor based RC phase shift oscillator.
- ✓ The circuit diagram is shown below.

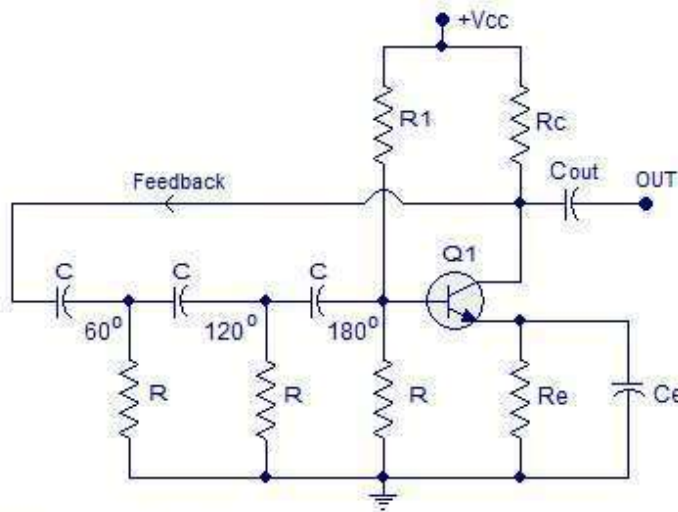

RC Phase shift oscillator

- ✓ In the circuit diagram resistor R1 and the resistor R (close to the base of Q1 in the diagram) gives a voltage divider bias to the transistor Q1.
- ✓ Resistor Rc limits the collector current while Re is meant for thermal stability.
- ✓ Ce is the emitter by-pass capacitor and Cout is the output DC decoupling capacitor.
- ✓ By using more than three RC phase shift stages (like 4 x 45°) the frequency stability of the oscillator can be further improved.
- ✓ The frequency of the transistor RC phase shift oscillator can be expressed by the equation:

$$F = \frac{1}{2\pi RC\sqrt{2N}}$$

Where F is the frequency, R is the resistance, C is the capacitance and N is the number of RC phase shift stages.

- ✓ The RC phase shift oscillator can be made variable by making the resistors or capacitors variable.
- ✓ The common approach is to leave the resistors untouched while the three capacitors are replaced by a triple gang variable capacitor.

## UNIT-7: FIELD EFFECT TRANSISTOR

### 7.1 FET (FIELD EFFECT TRANSISTOR):

Field effect transistor or FET is a transistor, where output current is controlled by electric field. FET sometimes, is called uni-polar transistor as it involves single carrier type operation. The basic type of FET transistor is completely different from BJT transistor basics. FET is three terminal semiconductor devices, with source, drain and gate terminals.

The charge carries are electrons or holes, which flow from the source to drain through an active channel. This flow of electrons from source to drain is controlled by voltage applied across the gate and source terminals.

### TYPES OF FET TRANSISTOR

FETs are of two types- JFETs or MOSFETs.

#### Junction FET

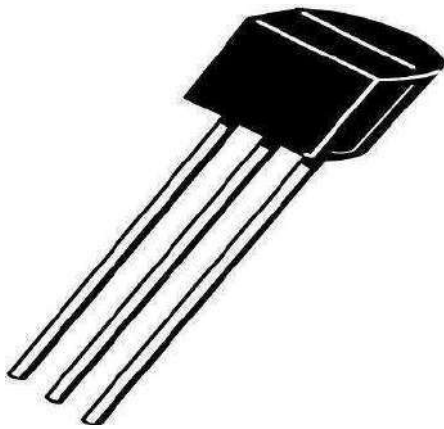

The Junction FET transistor is a type of field effect transistor that can be used as an electrically controlled switch. The electric energy flows through an active channel between sources to drain terminals. By applying a reverse bias voltage to gate terminal, the channel is strained so the electric current is switched off completely.

The junction FET transistor is available in two polarities which are;

1. N-Channel JFET
2. P-Channel JFET

## **MOSFET Transistor**



MOSFET transistor as its name suggests is a p type (n type) semiconductor bar (with two heavily doped n type regions diffused into it) with a metal oxide layer deposited on its surface and holes taken out of the layer to form source and drain terminals. A metal layer is deposited on the oxide layer to form the gate terminal. One of the basic applications of field effect transistor is using a MOSFET as a switch.

This type of FET transistor has three terminals, which are source, drain, and gate. The voltage applied to the gate terminal controls the flow of current from source to drain. The presence of an insulating layer of metal oxide results in the device having high input impedance.

MOSFET is of two types. They are:

1. Enhancement type MOSFET
2. Depletion type MOSFET

### **7.2 ADVANTAGES OF FET OVER BJT**

There are many advantages of FET's over BJT's here I'm providing few of them as follows

1. BJT'S are highly noisy devices than the FET's.
2. BJT's causes much and more loading effect than that of the FET's. Which is the major disadvantage of using BJT in circuit where loading effect should be avoided.

3. FET's are faster switching devices than that of the BJT. Because FET is majority carrier device.
4. FET's are smaller than BJT, thus FET takes lesser area on semiconductor die and they have higher input impedance than that of the BJT.
5. BJT's VI characteristics are linear while FET's have non-linear characteristics. Thus it's the advantages of using the BJT in its linear region for amplification process rather than using the FET.
6. Thermal stability of FET's are higher than the BJT's, because FET'S are unipolar devices that is current flow in FET depends upon the majority carriers only.

### 7.3 PRINCIPLE OPERATION OF JFET:

#### Construction of JFET

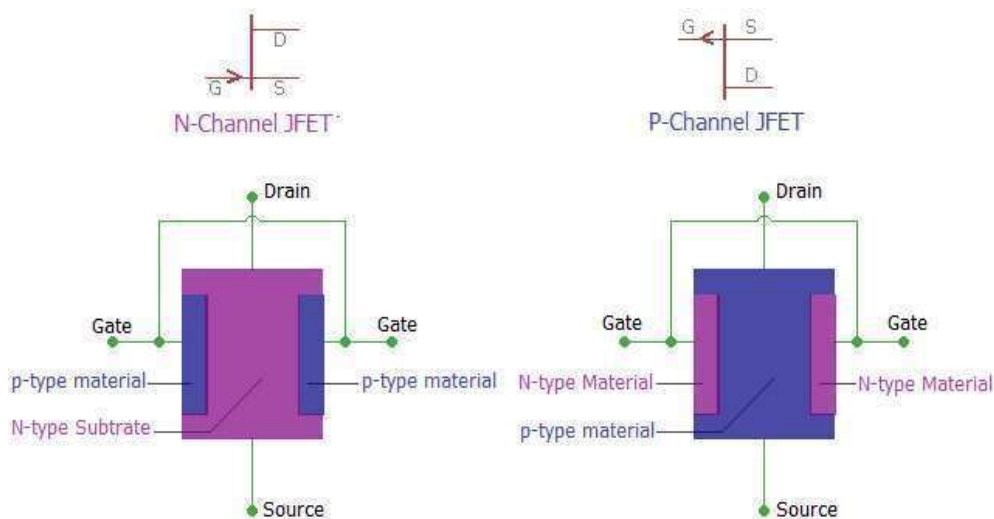

In the above image, we can see the basic construction of a JFET. The N-Channel JFET consists of P-type material in N-type substrate whereas N-type materials are used in the p-type substrate to form a P channel JFET.

JFET is constructed using the long channel of semiconductor material. Depending on the construction process, if the JFET contains a great number of positive charge carriers (refers as holes) is a P-type JFET, and if it has a large number of negative charge carriers (refers as electrons) is called N-type JFET.

In the long channel of semiconductor material, Ohmic contacts at each end are created to form the Source and Drain connections. A P-N junction is formed in one or both side of the channel.

#### Working of JFET

When there is no voltage across gate and source, the channel becomes a smooth path which is wide open for electrons to flow. But the reverse thing happens when a voltage is applied between gate and source in reverse polarity that makes the P-N



junction reversed biased and makes the channel narrower by increasing the depletion layer and could put the JFET in cut-off or pinch off region.

In the below image we can see the saturation mode and pinch off mode and we will be able to understand the depletion layer became wider and the current flow becomes less.

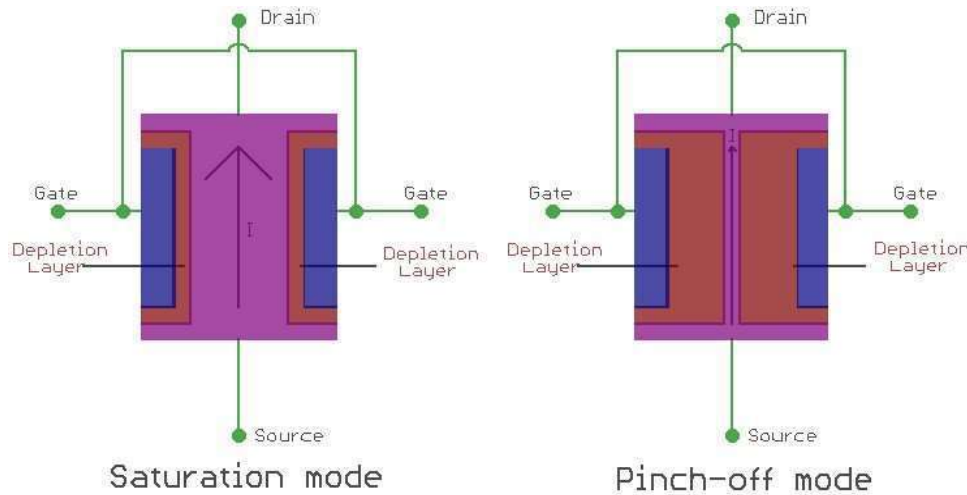

If we want to switch off a JFET we need to provide a negative gate to source voltage denoted as  $V_{GS}$  for an N-type JFET. For a P-type JFET, we need to provide positive  $V_{GS}$ .

JFET only works in the depletion mode, whereas MOSFETs have depletion mode and enhancement mode.

#### 7.4 FET PARAMETERS:

During purchasing a JFET for a particular application we need to check the specifications of the device. These specifications are provided by manufacturers. The followings are the parameters used to specify a JFET and these are

- Gate Cut Off Voltage ( $V_{GS(off)}$ )
- Shorted Gate Drain Current ( $I_{DSS}$ )
- Trans-conductance ( $g_{m0}$ )
- Dynamic Output Resistance ( $r_d$ )
- Amplification Factor ( $\mu$ )

#### Gate Cut Off Voltage

At a fixed drain voltage, the drain current ( $I_D$ ) of a JFET depends on the gate to source voltage ( $V_{GS}$ ). If the gate to source voltage decreases from zero in n channel JFET, the drain current also gets decreased accordingly. The relation between gate to source voltage and drain current is given below.

$$I_D = I_{DSS} \left[ 1 - \frac{V_{GS}}{V_{GS(off)}} \right]^2$$

When the gate terminal is grounded ( $V_{GS} = 0$ ) and positive drain to source voltage ( $V_{DS}$ ) is being increased slowly in case of n channel JFET, the drain current gets increased linearly. But after pinch-off voltage ( $V_p$ ), the drain current would not be increased further and gets a constant value. This is the maximum drain current that can flow through the channel when the gate terminal is in ground potential. This current is fixed for a JFET and this is called shorted gated drain current and generally denoted by  $I_{DSS}$ .

### Dynamic Output Resistance

This is the ratio of change of drain to source voltage ( $\delta V_{DS}$ ) to the change of drain current ( $\delta I_D$ ) at a constant gate to source voltage ( $V_{GS} = \text{Constant}$ ). The ratio is denoted as  $r_d$ .

$$r_d = \frac{\delta V_{DS}}{\delta I_D} \text{ at constant } V_{GS}$$

### Amplification Factor

The amplification factor is defined as the ratio of change of drain voltage ( $\delta V_{DS}$ ) to change of gate voltage ( $\delta V_{GS}$ ) at a constant drain current ( $I_D = \text{Constant}$ ).

$$\mu = \frac{\delta V_{DS}}{\delta V_{GS}} \text{ at constant } I_D$$

There is a relation between trans-conductance ( $g_m$ ) and dynamic output resistance ( $r_d$ ) and that can be established in the following way.

$$\begin{aligned} \mu &= \frac{\delta V_{DS}}{\delta V_{GS}} = \frac{\delta V_{DS}}{\delta I_D} \times \frac{\delta I_D}{\delta V_{GS}} \\ &\Rightarrow \mu = r_d \times g_m \end{aligned}$$

### Trans-conductance

Trans-conductance is the ratio of change in drain current ( $\delta I_D$ ) to change in the gate to source voltage ( $\delta V_{GS}$ ) at a constant drain to source voltage ( $V_{DS} = \text{Constant}$ ).

$$g_m = \frac{\delta I_D}{\delta V_{GS}} \text{ at constant } V_{DS}$$

This value is maximum at  $V_{GS} = 0$ . This is denoted by  $g_{m0}$ . This maximum value ( $g_{m0}$ ) is specified in a JFET data sheet. The trans-conductance at any other value of gate to

source voltage ( $g_m$ ) can be determined as follows. The expression of drain current ( $I_D$ ) is

$$I_D = I_{DSS} \left[ 1 - \frac{V_{GS}}{V_{GS(off)}} \right]^2$$

By partial differentiating the expression of drain current ( $I_D$ ) in respect of gate to source voltage ( $V_{GS}$ )

$$g_m = \frac{\delta I_D}{\delta V_{GS}} = \frac{2I_{DSS}}{V_{GS(off)}} \left[ 1 - \frac{V_{GS}}{V_{GS(off)}} \right]$$

At  $V_{GS} = 0$ , the trans-conductance gets its maximum value and that is

$$g_{mo} = \frac{2I_{DSS}}{V_{GS(off)}}$$

Therefore, we can write,

$$g_m = g_{mo} \left[ 1 - \frac{V_{GS}}{V_{GS(off)}} \right]$$

## 7.5 BIASING OF FET:

MOSFET bias circuits are similar to those used for JFETs. Various FET biasing circuits are discussed below:

### Fixed Bias.

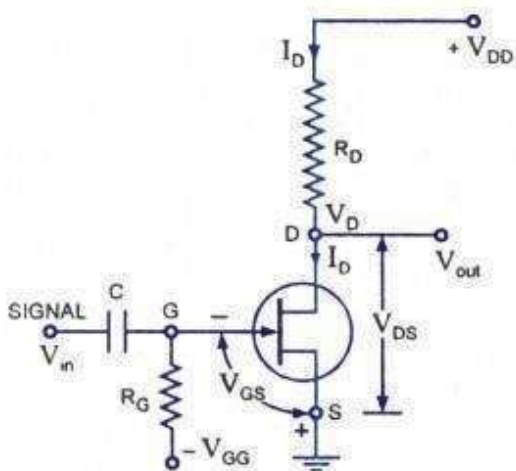

*Fixed Biasing Circuit For JFET*

DC bias of a FET device needs setting of gate-source voltage  $V_{GS}$  to give desired drain current  $I_D$ . For a JFET drain current is limited by the saturation current  $I_{DS}$ . Since the FET has such a high input impedance that no gate current flows and the dc voltage of the gate set by a voltage divider or a fixed battery voltage is not affected or loaded by the FET.

Fixed dc bias is obtained using a battery  $V_{GG}$ . This battery ensures that the gate is always negative with respect to source and no current flows through resistor  $R_G$  and gate terminal that is  $I_G = 0$ . The battery provides a voltage  $V_{GS}$  to bias the N-channel JFET, but no resulting current is drawn from the battery  $V_{GG}$ . Resistor  $R_G$  is included to allow any ac signal applied through capacitor  $C$  to develop across  $R_G$ . While any ac signal will develop across  $R_G$ , the dc voltage drop across  $R_G$  is equal to  $I_G R_G$  i.e. 0 volt.

The gate-source voltage  $V_{GS}$  is then

$$V_{GS} = -V_G - V_S = -V_{GG} - 0 = -V_{GG}$$

The drain-source current  $I_D$  is then fixed by the gate-source voltage as determined by equation.

This current then causes a voltage drop across the drain resistor  $R_D$  and is given as  $V_{RD} = I_D R_D$  and output voltage,  $V_{out} = V_{DD} - I_D R_D$

### Self-Bias.

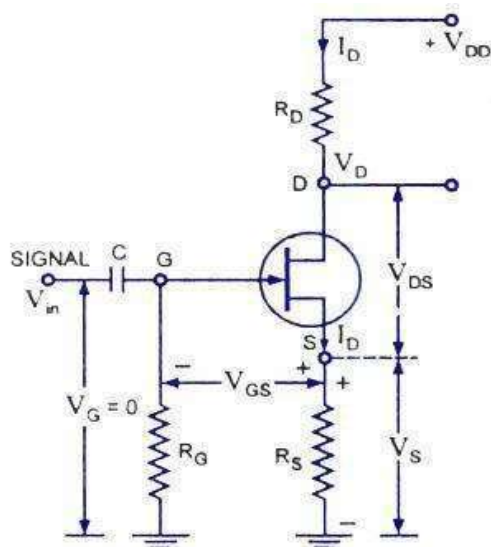

*Self-Bias Circuit For N-Channel JFET*

This is the most common method for biasing a JFET. Self-bias circuit for N-channel JFET is shown in figure.

Since no gate current flows through the reverse-biased gate-source, the gate current  $I_G = 0$  and, therefore,  $v_G = i_G R_G = 0$

With a drain current  $I_D$  the voltage at the S is

$$V_S = I_D R_S$$

The gate-source voltage is then

$$V_{GS} = V_G - V_S = 0 - I_D R_S = -I_D R_S$$

So voltage drop across resistance  $R_s$  provides the biasing voltage  $V_{Gg}$  and no external source is required for biasing and this is the reason that it is called self-biasing.

The operating point (that is zero signal  $I_D$  and  $V_{DS}$ ) can easily be determined from equation and equation given below:

$$V_{DS} = V_{DD} - I_D (R_D + R_S)$$

Thus dc conditions of JFET amplifier are fully specified. Self-biasing of a JFET stabilizes its quiescent operating point against any change in its parameters like trans-conductance. Let the given JFET be replaced by another JFET having the double conductance then drain current will also try to be double but since any increase in voltage drop across  $R_s$ , therefore, gate-source voltage,  $V_{GS}$  becomes more negative and thus increase in drain current is reduced.

### Potential-Divider Biasing.

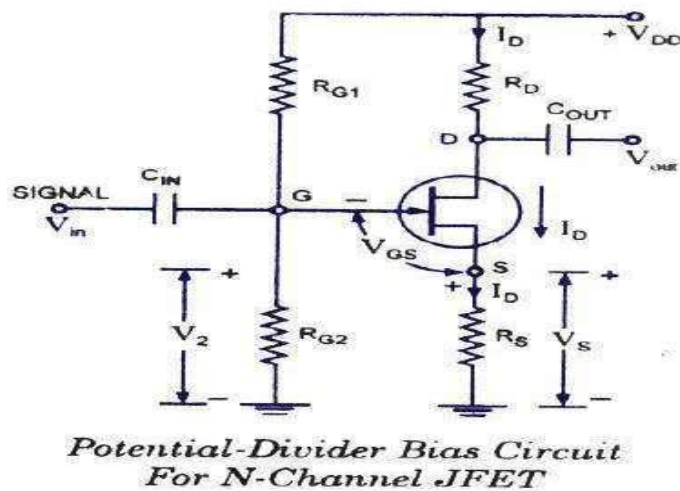

A slightly modified form of dc bias is provided by the circuit shown in figure. The resistors  $R_{G1}$  and  $R_{G2}$  form a potential divider across drain supply  $V_{DD}$ . The voltage  $V_2$  across  $R_{G2}$  provides the necessary bias. The additional gate resistor  $R_{G1}$  from gate to supply voltage facilitates in larger adjustment of the dc bias point and permits use of larger valued  $R_s$ .

The gate is reverse biased so that  $I_G = 0$  and gate voltage

$$V_G = V_2 = (V_{DD}/R_{G1} + R_{G2}) * R_{G2}$$

And

$$V_{GS} = V_G - V_S = V_G - I_D R_S$$

The circuit is so designed that  $I_D R_s$  is greater than  $V_G$  so that  $V_{GS}$  is negative. This provides correct bias voltage.

The operating point can be determined as

$$I_D = (V_2 - V_{GS}) / R_S$$

And

$$V_{DS} = V_{DD} - I_D (R_D + R_S)$$

## UNIT-8: OPERATIONAL AMPLIFIER

### 8.1 GENERAL CIRCUIT OF OP-AMP:

Op amp is basically a multistage amplifier in which a number of amplifier stages are interconnected to each other in a very complicated manner. Its internal circuit consists of many transistors, FETs and resistors. All this occupies a very little space.

So, it is packed in a small package and is available in the Integrated Circuit (IC) form. The term **Op Amp** is used to denote an amplifier which can be configured to perform various operations like amplification, subtraction, differentiation, addition, integration etc. An example is the very popular IC 741.

The symbol and its actual appearance in the IC form is shown below. The symbol appears as an arrowhead which signifies that the signal is flowing from output to input.

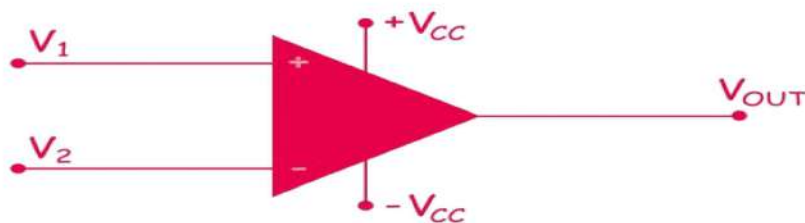

#### Input and Output Terminals of an Operational Amplifier

An op-amp has two input terminals and one output terminal. The op-amp also has two voltage supply terminals as seen above. Two input terminals form the differential input. We call the terminal, marked with negative (-) sign as the inverting terminal and the terminal marked with positive (+) sign as the non-inverting terminal of the **operational amplifier**. If we apply an input signal at the inverting terminal (-) then the amplified output signal is  $180^\circ$  out of phase concerning the applied input signal. If we apply an input signal to the non-inverting terminal (+) then the output signal obtained will be in phase, i.e. it will have no phase shift concerning the input signal.

#### Power Supply for an Operational Amplifier

As seen from the circuit symbol above it has two input power supply terminals  $+V_{CC}$  and  $-V_{CC}$ . For the operation of an op-amp a dual polarity DC supply is essential. In

the dual polarity supply, we connect the  $+V_{CC}$  to the positive DC supply and the  $-V_{CC}$  terminal to the negative DC supply. However few op-amps can also operate on a single polarity supply. Note that there is no common ground terminal in the op-amps hence the ground has to be established externally.

## 8.2 OPERATIONAL AMPLIFIER STAGES (OP-AMP)

The different stages of a multi-stage operational amplifier are given below.

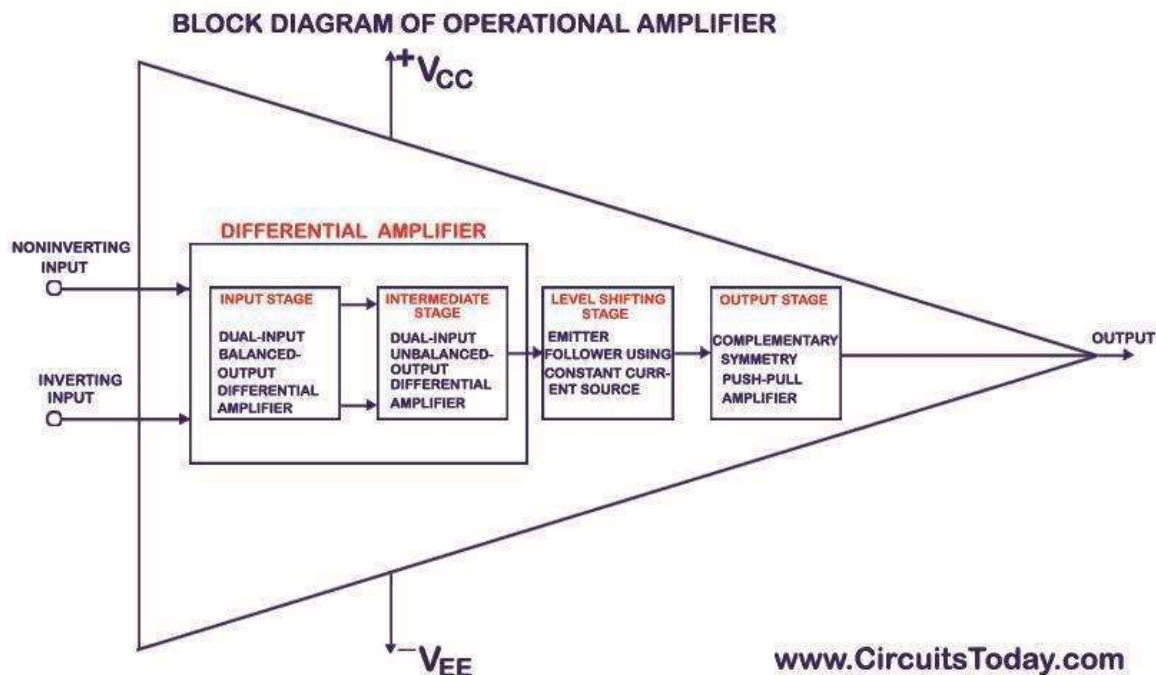

- The op-amp begins with a differential amplifier stage, which operates in the differential mode. Thus the inputs noted with '+' & '-'. The positive sign is for the non-inverting input and negative is for the inverting input.
- The non-inverting input is the ac signal (or dc) applied to the differential amplifier which produces the same polarity of the signal at the output of op-amp. The inverting signals input is the ac signal (or dc) applied to the differential amplifier. This produces 180 degrees out of phase signal at the output.
- The inverting and non-inverting inputs are provided to the input stage which is a dual input, balanced output differential amplifier. The voltage gain required for the amplifier is provided in this stage along with the input resistance for the op-amp.
- The output of the initial stage is given to the intermediate stage, which is driven by the output of the input stage. In this stage direct coupling is used, which makes the dc voltage at the output of the intermediate stage above ground potential.
- Therefore, the dc level at its output must be shifted down to 0Volts with respect to the ground. For this, the level shifting stage is used where usually an emitter follower with the constant current source is applied. The level shifted signal is then given to the output stage where a push-pull amplifier increases the output voltage swing of the signal and also increases the current supplying capability of the op-amp.

### 8.3 EQUIVALENT CIRCUIT OF AN OP-AMP:

The equivalent circuit of an ideal op-amp is shown above. The input voltage  $V_{DIFF}$  is the difference voltage ( $V_1 - V_2$ ).  $Z_{in}$  is the input impedance and  $Z_{out}$  is the output impedance. The gain parameter  $A$  is called the open loop gain. If an op-amp does not have any feedback from the output to either of the inputs, it is said to be operating in open-loop configuration.

An ideal op-amp exhibits infinite open loop gain, infinite input impedance, zero output impedance, infinite voltage swing, infinite bandwidth, infinite slew rate and zero input offset voltage.

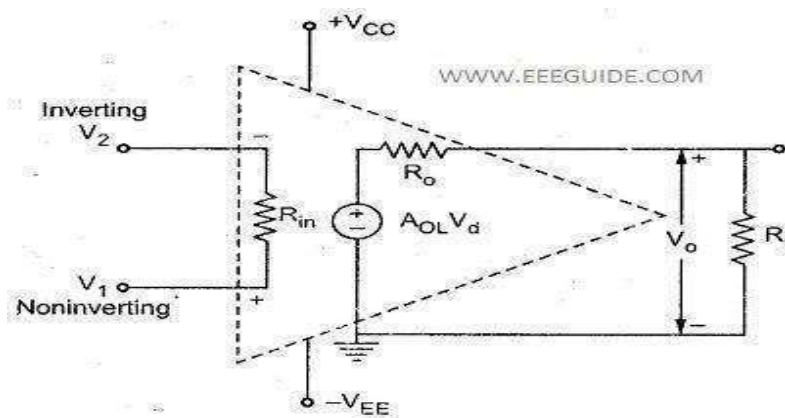

FIG(A) Equivalent circuit of an op-amp

### 8.4 OPEN LOOP OPERATION OF AN OPERATIONAL AMPLIFIER

op-amp has a differential input and single ended output. So, if we apply two signals one at the inverting and another at the non-inverting terminal, an ideal op-amp will amplify the difference between the two applied input signals. We call this difference between two input signals as the differential input voltage. The equation below gives the output of an operational amplifier.

$$V_{OUT} = A_{OL}(V_1 - V_2)$$

Where,  $V_{OUT}$  is the voltage at the output terminal of the op-amp.

$A_{OL}$  is the open-loop gain for the given op-amp and is constant (ideally). For the IC 741  $A_{OL}$  is  $2 \times 10^5$ .

$V_1$  is the voltage at the non-inverting terminal.

$V_2$  is the voltage at the inverting terminal.

$(V_1 - V_2)$  is the differential input voltage.



It is clear from the above equation that the output will be non-zero if and only if the differential input voltage is non-zero ( $V_1$  and  $V_2$  are not equal), and will be zero if both  $V_1$  and  $V_2$  are equal.

This is an ideal condition; practically there are small imbalances in the op-amp. The open-loop gain of an op-amp is very high. Hence, an open loop operational amplifier amplifies a small applied differential input voltage to a huge value.

Also, it is true that if we apply small differential input voltage, the operational amplifier amplifies it to a considerable value but this significant value at the output cannot go beyond the supply voltage of the op-amp. Hence it does not violate the law of conservation of energy.

## 8.5 CLOSED LOOP OPERATION (OP-AMP WITH FEEDBACK)

The above-explained operation of the op-amp was for open-loop i.e. without a feedback.

Feedback is introduced in the closed loop configuration. This feedback path feeds the output signal to the input. Hence, at the inputs, two signals are simultaneously present. One of them is the original applied signal, and the other is the feedback signal.

The equation below shows the output of a closed loop op-amp.

$$V_{OUT} = A_{CL}(V_1 - V_2) = A_{CL}V_D$$

Where,  $V_{OUT}$  is the voltage at the output terminal of the op-amp.

$A_{CL}$  is the closed loop gain.

The feedback circuit connected to the op-amp determines the closed loop gain  $A_{CL}$ .

$V_D = (V_1 - V_2)$  is the differential input voltage.

The feedback is positive if the feedback path feeds the signal from the output terminal back to the non-inverting (+) terminal. Positive feedback is used in oscillators.

The feedback is negative if the feedback path feeds the part of the signal from the output terminal back to the inverting (-) terminal. Negative feedback to the op-amps is used as amplifiers.

Each type of feedback, negative or positive has its advantages and disadvantages.

Positive Feedback  $\Rightarrow$  Oscillator

Negative Feedback  $\Rightarrow$  Amplifier

The above explanation is the most basic **working principle of operational amplifiers**.

## Ideal Op-Amp Characteristics

An ideal op-amp should have the following characteristics:

1. Infinite voltage gain (So that maximum output is obtained)
2. Infinite input resistance (Due to this almost any source can drive it)
3. Zero output resistance (So that there is no change in output due to change in load current)
4. Infinite bandwidth

5. Zero noise
6. Zero power supply rejection ratio (PSSR = 0)
7. Infinite common mode rejection ratio (CMMR =  $\infty$ )

### Practical Operational Amplifier

None of the above-given parameters can be practically realized. A practical or real op-amp has some unavoidable imperfections and hence its characteristics differ from the ideal one. A real op-amp will have non-zero and non-infinite parameters.

### Applications of Operational Amplifier

The integrated op-amps offer all the advantages of ICs such as high reliability, small size, cheap, less power consumption. They are used in variety of applications such as inverting amplifier and non-inverting amplifiers, unity gain buffer, summing amplifier, differentiator, integrator, adder, instrumentation amplifier, Wien bridge oscillator, Filters etc.

### 8.6 INVERTING OPERATIONAL AMPLIFIER CONFIGURATION

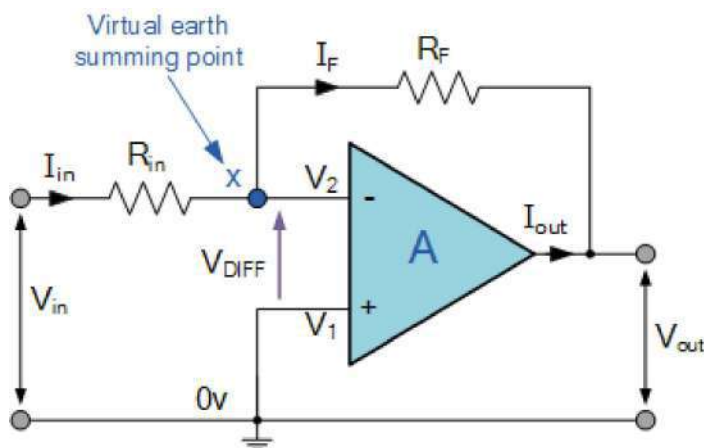

In this Inverting Amplifier circuit the operational amplifier is connected with feedback to produce a closed loop operation. When dealing with operational amplifiers there are two very important rules to remember about inverting amplifiers, these are: “No current flows into the input terminal” and that “V1 always equals V2”. However, in real world op-amp circuits both of these rules are slightly broken.

This is because the junction of the input and feedback signal ( X ) is at the same potential as the positive ( + ) input which is at zero volts or ground then, the junction is a “Virtual Earth”. Because of this virtual earth node the input resistance of the amplifier is equal to the value of the input resistor, Rin and the closed loop gain of the inverting amplifier can be set by the ratio of the two external resistors.

There are two very important rules to remember about Inverting Amplifiers or any operational amplifier for that matter and these are.

- No Current Flows into the Input Terminals
- The Differential Input Voltage is Zero as  $V_1 = V_2 = 0$  (Virtual Earth)

Then by using these two rules we can derive the equation for calculating the closed-loop gain of an inverting amplifier, using first principles.

Current ( $i$ ) flows through the resistor network as shown.

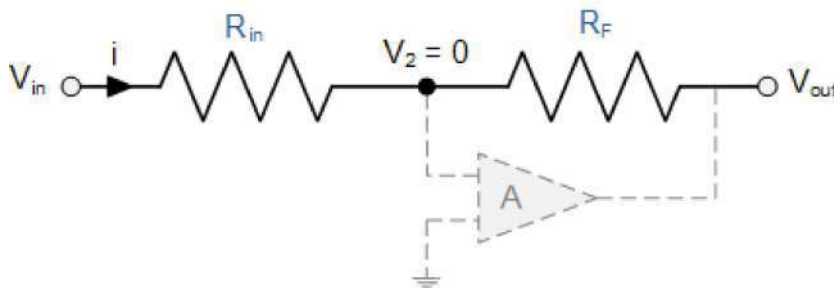

$$i = \frac{V_{in} - V_{out}}{R_{in} + R_f}$$

therefore,  $i = \frac{V_{in} - V_2}{R_{in}} = \frac{V_2 - V_{out}}{R_f}$

$$i = \frac{V_{in}}{R_{in}} - \frac{V_2}{R_{in}} = \frac{V_2}{R_f} - \frac{V_{out}}{R_f}$$

so,  $\frac{V_{in}}{R_{in}} = V_2 \left[ \frac{1}{R_{in}} + \frac{1}{R_f} \right] - \frac{V_{out}}{R_f}$

and as,  $i = \frac{V_{in} - 0}{R_{in}} = \frac{0 - V_{out}}{R_f} \frac{R_f}{R_{in}} = \frac{0 - V_{out}}{V_{in} - 0}$

the closed loop Gain ( $A_v$ ) is given as,  $\frac{V_{out}}{V_{in}} = - \frac{R_f}{R_{in}}$

Then, the **Closed-Loop Voltage Gain** of an Inverting Amplifier is given as.

$$\text{Gain } (A_v) = \frac{V_{out}}{V_{in}} = - \frac{R_f}{R_{in}}$$

And this can be transposed to give  $V_{out}$  as:

$$V_{out} = - \frac{R_f}{R_{in}} \times V_{in}$$

The negative sign in the equation indicates an inversion of the output signal with respect to the input as it is  $180^\circ$  out of phase. This is due to the feedback being negative in value.

The equation for the output voltage  $V_{out}$  also shows that the circuit is linear in nature for a fixed amplifier gain as  $V_{out} = V_{in} \times \text{Gain}$ . This property can be very useful for converting a smaller sensor signal to a much larger voltage.

### 8.7 NON-INVERTING OPERATIONAL AMPLIFIER CONFIGURATION

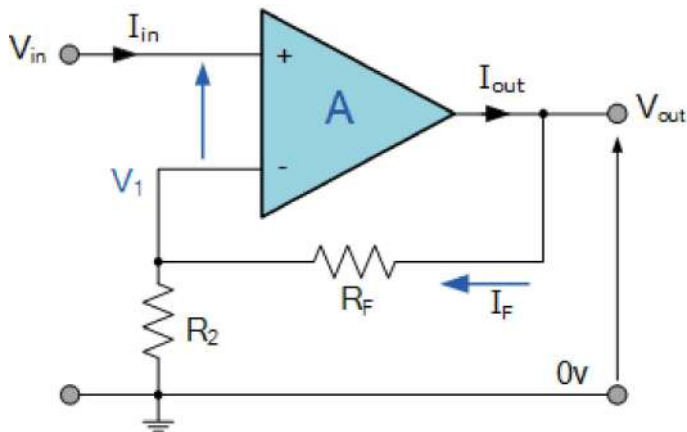

In the previous Inverting Amplifier tutorial, we said that for an ideal op-amp “No current flows into the input terminal” of the amplifier and that “ $V_1$  always equals  $V_2$ ”. This was because the junction of the input and feedback signal ( $V_1$ ) are at the same potential.

In other words the junction is a “virtual earth” summing point. Because of this virtual earth node the resistors,  $R_f$  and  $R_2$  form a simple potential divider network across the non-inverting amplifier with the voltage gain of the circuit being determined by the ratios of  $R_2$  and  $R_f$  as shown below.

#### Equivalent Potential Divider Network

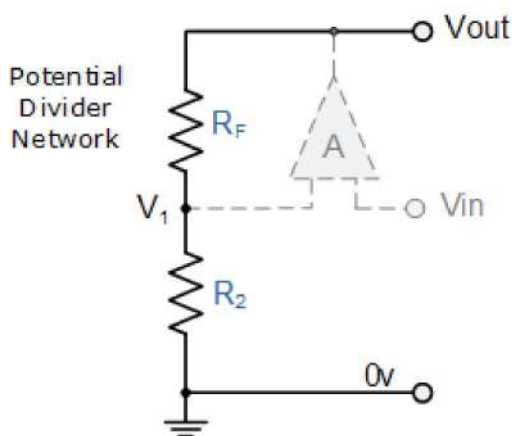

Then using the formula to calculate the output voltage of a potential divider network, we can calculate the closed-loop voltage gain ( $A_V$ ) of the **Non-inverting Amplifier** as follows:

$$V_1 = \frac{R_2}{R_2 + R_f} \times V_{out}$$

Ideal summing point:  $V_1 = V_{in}$

Voltage Gain,  $A_V$  is equal to:  $\frac{V_{out}}{V_{in}}$

$$\text{Then, } A_V = \frac{V_{out}}{V_{in}} = \frac{R_2 + R_f}{R_2}$$

$$\text{Transpose to give: } A_V = \frac{V_{out}}{V_{in}} = 1 + \frac{R_f}{R_2}$$

Then the closed loop voltage gain of a **Non-inverting Operational Amplifier** will be given as:

$$A_V = \frac{V_{out}}{V_{in}} = 1 + \frac{R_f}{R_2}$$

We can see from the equation above that the overall closed-loop gain of a non-inverting amplifier will always be greater but never less than one (unity), it is positive in nature and is determined by the ratio of the values of  $R_f$  and  $R_2$ .

If the value of the feedback resistor  $R_f$  is zero, the gain of the amplifier will be exactly equal to one (unity). If resistor  $R_2$  is zero the gain will approach infinity, but in practice it will be limited to the operational amplifiers open-loop differential gain, ( $A_o$ ).

We can easily convert an inverting operational amplifier configuration into a non-inverting amplifier configuration by simply changing the input connections as shown.

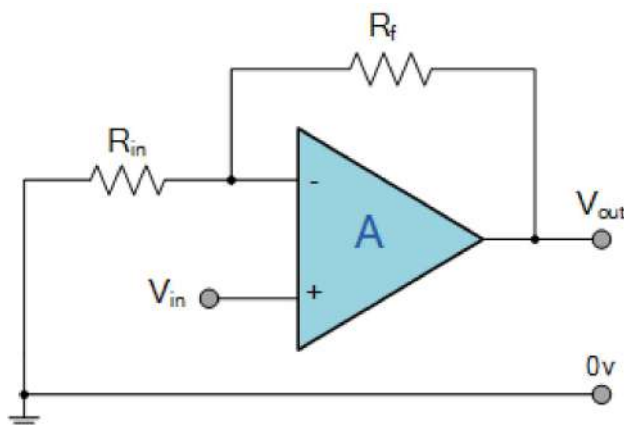

## 8.8 VOLTAGE FOLLOWER AND BUFFER

**Voltage follower** is an Op-amp circuit whose output voltage straight away follows the input voltage. That is output voltage is equivalent to the input voltage. Op-amp circuit does not provide any amplification. Thus, voltage gain is equal to 1. They are similar to discrete emitter follower. The other names of voltage follower are Isolation Amplifier, Buffer Amplifier, and Unity-Gain Amplifier. The voltage follower provides no attenuation or no amplification but only buffering. This circuit has an advantageous characteristic of very high input impedance. This high input impedance of voltage follower is the reason of it being used in several circuits. The **voltage follower** gives an efficient isolation of output from the input signal. The circuit of voltage follower is shown below.

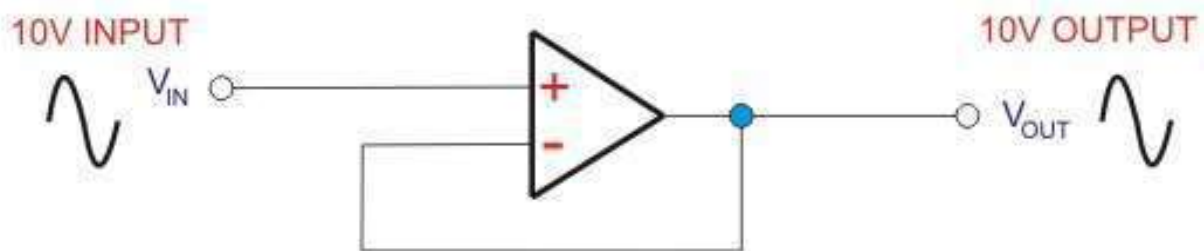

We all know the most fundamental law; that is Ohm's law.

$$\text{Current} = \frac{\text{Voltage}}{\text{Resistance}}$$

So, we can say that when resistance increases, the current drawn from the power source decreases. Thus, we conclude that the power is unaffected if the current is feeding a load of high impedance.

## 8.9 DIFFERENTIAL AMPLIFIER

### 8.9.1 Summing Amplifier Circuit

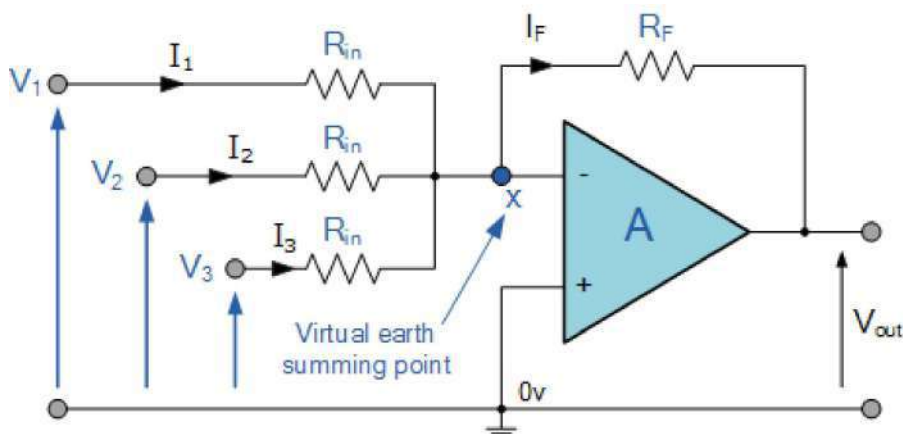

In this simple summing amplifier circuit, the output voltage, (  $V_{out}$  ) now becomes proportional to the sum of the input voltages,  $V_1$ ,  $V_2$ ,  $V_3$ , etc. Then we can modify the original equation for the inverting amplifier to take account of these new inputs thus:

$$I_F = I_1 + I_2 + I_3 = - \left[ \frac{V_1}{R_{in}} + \frac{V_2}{R_{in}} + \frac{V_3}{R_{in}} \right]$$

Inverting equation:  $V_{out} = - \frac{R_f}{R_{in}} \times V_{in}$

Then,  $-V_{out} = \left[ \frac{R_f}{R_{in}} V_1 + \frac{R_f}{R_{in}} V_2 + \frac{R_f}{R_{in}} V_3 \right]$

However, if all the input impedances, (  $R_{IN}$  ) are equal in value, we can simplify the above equation to give an output voltage of:

Summing Amplifier Equation

$$-V_{out} = \frac{R_f}{R_{in}} ( V_1 + V_2 + V_3 )$$

An operational amplifier circuit will amplify each individual input voltage and produce an output voltage signal that is proportional to the algebraic "SUM" of the three individual input voltages  $V_1$ ,  $V_2$  and  $V_3$ .

This is because the input signals are effectively isolated from each other by the "virtual earth" node at the inverting input of the op-amp. A direct voltage addition can also be obtained when all the resistances are of equal value and  $R_f$  is equal to  $R_{in}$ .

When the summing point is connected to the inverting input of the op-amp the circuit will produce the negative sum of any number of input voltages. Likewise, when the summing point is connected to the non-inverting input of the op-amp, it will produce the positive sum of the input voltages.

**A Scaling Summing Amplifier** can be made if the individual input resistors are "NOT" equal. Then the equation would have to be modified to:

$$-V_{out} = V_1 \left( \frac{R_f}{R_1} \right) + V_2 \left( \frac{R_f}{R_2} \right) + V_3 \left( \frac{R_f}{R_3} \right)$$

We can rearrange the above formula to make the feedback resistor  $R_f$  the subject of the equation giving the output voltage as:

$$-V_{out} = R_f \left( \frac{V_1}{R_1} + \frac{V_2}{R_2} + \frac{V_3}{R_3} \right)$$

This allows the output voltage to be easily calculated if more input resistors are connected to the amplifiers inverting input terminal. The input impedance of each individual channel is the value of their respective input resistors, ie,  $R_1$ ,  $R_2$ ,  $R_3$  ... etc.

Sometimes we need a summing circuit to just add together two or more voltage signals without any amplification. By putting all of the resistances of the circuit above to the same value  $R$ , the op-amp will have a voltage gain of unity and an output voltage equal to the direct sum of all the input voltages as shown:

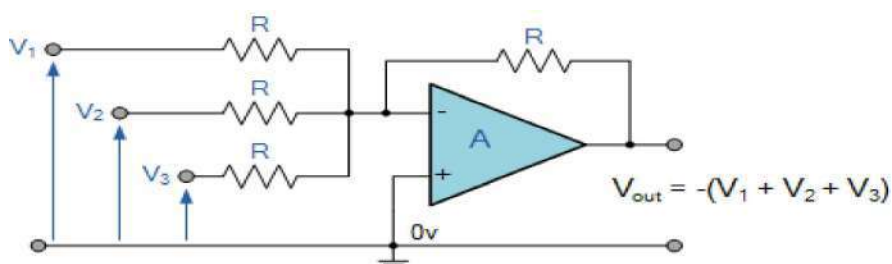

The **Summing Amplifier** is a very flexible circuit indeed, enabling us to effectively “Add” or “Sum” (hence its name) together several individual input signals. If the inputs resistors,  $R_1, R_2, R_3$  etc, are all equal a “unity gain inverting adder” will be made. However, if the input resistors are of different values a “scaling summing amplifier” is produced which will output a weighted sum of the input signals.

### 8.9.2 Op-amp Sub tractor Circuit:

A difference amplifier or op amp subtractor is a specially designed op amp based amplifier circuit, which amplifies the difference between two input signals and rejects any signals common to both inputs.

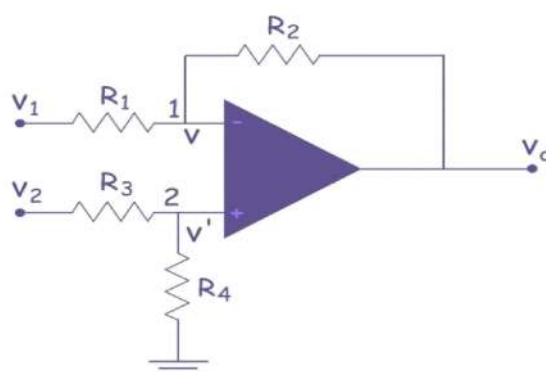

Let us consider the above op amp circuit. Now, by applying Kirchhoff Current Law at node 1, we get,

$$\frac{v_1 - v}{R_1} = \frac{v - v_0}{R_2}$$

We have written this equation by assuming that there is no current entering in the inverting terminal of the op amp.

Now, by simplifying the above equation, we get,

$$\begin{aligned} \frac{v_1}{R_1} + \frac{v_0}{R_2} &= \frac{v}{R_1} + \frac{v}{R_2} \\ \Rightarrow \frac{v_0}{R_2} &= \frac{v}{R_1} + \frac{v}{R_2} - \frac{v_1}{R_1} \\ \Rightarrow v_0 &= \left( \frac{R_2}{R_1} + 1 \right) v - \frac{R_2}{R_1} v_1 \Rightarrow v_0 = \left( 1 + \frac{R_2}{R_1} \right) v - \frac{R_2}{R_1} v_1 \dots\dots (i) \end{aligned}$$



Now, by applying Kirchhoff Current Law, at node 2, we get,

$$\frac{v_2 - v'}{R_3} = \frac{v' - 0}{R_4} \Rightarrow v_2 = v' \left( 1 + \frac{R_3}{R_4} \right)$$

$$\Rightarrow \frac{v_2}{R_3} = \frac{v'}{R_4} + \frac{v'}{R_3} \Rightarrow v' = v_2 \left( \frac{R_4}{R_3 + R_4} \right) \dots\dots (ii)$$

We know that, in ideal op amp, voltage at inverting input is same as the voltage at non inverting input. Hence,

$$v = v'$$

So, now from equation (i) and (ii), we get,

$$v_0 = \left( 1 + \frac{R_2}{R_1} \right) \frac{R_4}{R_3 + R_4} v_2 - \frac{R_2}{R_1} v_1$$

$$\Rightarrow v_0 = \frac{\left( 1 + \frac{R_2}{R_1} \right)}{\left( 1 + \frac{R_3}{R_4} \right)} v_2 - \frac{R_2}{R_1} v_1$$

$$v_0 = \frac{R_2}{R_1} \cdot \frac{1 + \frac{R_1}{R_2}}{1 + \frac{R_3}{R_4}} v_2 - \frac{R_2}{R_1} v_1 \dots\dots\dots (iii)$$

The **difference amplifier** must reject any signal common to both inputs. That means, if polarity and magnitude of both input signals are same, the output must be zero.

$$\therefore \text{when, } v_1 = v_2, \text{ then, } v_0 = 0$$

This condition must be satisfied only when,

$$\frac{R_1}{R_2} = \frac{R_3}{R_4} \Leftrightarrow R_1 \cdot R_2 = R_3 \cdot R_4$$

In that case, equation (iii) becomes,

$$v_0 = \frac{R_2}{R_1} v_2 - \frac{R_2}{R_1} v_1$$

$$\Rightarrow v_0 = \frac{R_2}{R_1} (v_2 - v_1) \dots\dots\dots (iv)$$

Again, if we make,  $R_1 = R_2$ , then equation (iv) becomes,

$$v_0 = v_2 - v_1$$

So, if  $R_1 = R_2$  and also  $R_3 = R_4$  then the difference amplifier becomes a perfect subtractor, which subtracts directly the input signals.

Finally, the circuit of **op amp subtractor** becomes,

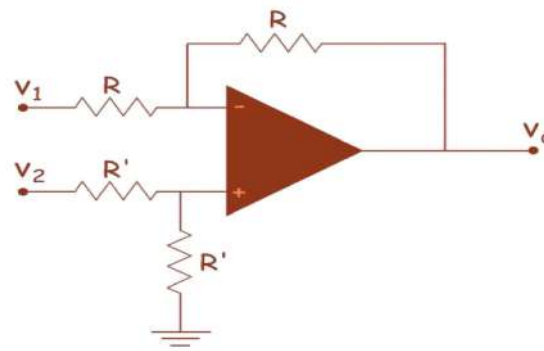

### 8.9.3 Op-amp Integrator Circuit

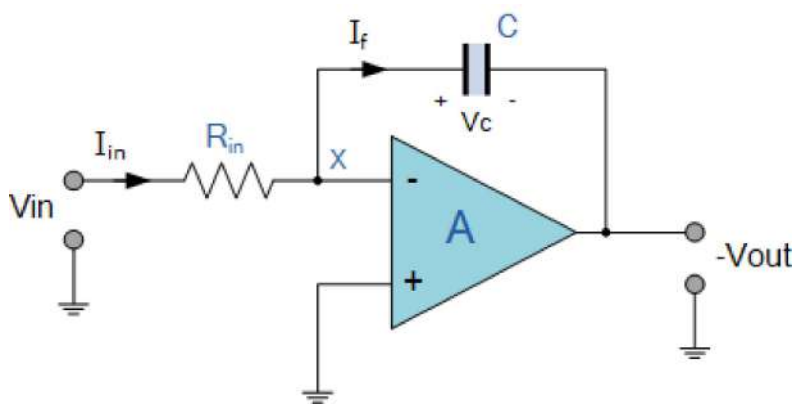

As its name implies, the **Op-amp Integrator** is an operational amplifier circuit that performs the mathematical operation of **integration** that is we can cause the output to respond to changes in the input voltage over time as the op-amp integrator produces an *output voltage which is proportional to the integral of the input voltage*.

When a step voltage,  $V_{in}$  is firstly applied to the input of an integrating amplifier, the uncharged capacitor  $C$  has very little resistance and acts a bit like a short circuit allowing maximum current to flow via the input resistor,  $R_{in}$  as potential difference exists between the two plates. No current flows into the amplifiers input and point  $X$  is a virtual earth resulting in zero output. As the impedance of the capacitor at this point is very low, the gain ratio of  $X_C/R_{IN}$  is also very small giving an overall voltage gain of less than one, (voltage follower circuit).

As the feedback capacitor,  $C$  begins to charge up due to the influence of the input voltage, its impedance  $X_c$  slowly increase in proportion to its rate of charge. The capacitor charges up at a rate determined by the  $RC$  time constant, ( $\tau$ ) of the series  $RC$  network. Negative feedback forces the op-amp to produce an output voltage that maintains a virtual earth at the op-amp's inverting input.

Since the capacitor is connected between the op-amp's inverting input (which is at virtual ground potential) and the op-amp's output (which is now negative), the potential voltage,  $V_c$  developed across the capacitor slowly increases causing the charging current to decrease as the impedance of the capacitor increases. This

results in the ratio of  $X_c/R_{in}$  increasing producing a linearly increasing ramp output voltage that continues to increase until the capacitor is fully charged.

At this point the capacitor acts as an open circuit, blocking any more flow of DC current. The ratio of feedback capacitor to input resistor ( $X_c/R_{IN}$ ) is now infinite resulting in infinite gain. The result of this high gain (similar to the op-amps open-loop gain), is that the output of the amplifier goes into saturation as shown below. (Saturation occurs when the output voltage of the amplifier swings heavily to one voltage supply rail or the other with little or no control in between).

The rate at which the output voltage increases (the rate of change) is determined by the value of the resistor and the capacitor, "RC time constant".

We know that the voltage on the plates of a capacitor is equal to the charge on the capacitor divided by its capacitance giving  $Q/C$ . Then the voltage across the capacitor is output  $V_{out}$  therefore:  $-V_{out} = Q/C$ . If the capacitor is charging and discharging, the rate of change of voltage across the capacitor is given as:

$$V_c = \frac{Q}{C}, V_c = V_x - V_{out} = 0 - V_{out}$$

$$-\frac{dV_{out}}{dt} = \frac{dQ}{C dt} = \frac{1}{C} \frac{dQ}{dt}$$

But  $dQ/dt$  is electric current and since the node voltage of the integrating op-amp at its inverting input terminal is zero,  $X = 0$ , the input current  $I_{in}$  flowing through the input resistor,  $R_{in}$  is given as:

$$I_{in} = \frac{V_{in} - 0}{R_{in}} = \frac{V_{in}}{R_{in}}$$

The current flowing through the feedback capacitor  $C$  is given as:

$$I_f = C \frac{dV_{out}}{dt} = C \frac{dQ}{C dt} = \frac{dQ}{dt} = \frac{dV_{out} \cdot C}{dt}$$

Assuming that the input impedance of the op-amp is infinite (ideal op-amp), no current flows into the op-amp terminal. Therefore, the nodal equation at the inverting input terminal is given as:

$$I_{in} = I_f = \frac{V_{in}}{R_{in}} = \frac{dV_{out} \cdot C}{dt}$$

$$\frac{V_{in}}{V_{out}} \times \frac{dt}{R_{in} C} = 1$$

From which we derive an ideal voltage output for the **Op-amp Integrator** as:

$$V_{out} = -\frac{1}{R_{in} C} \int_0^t V_{in} dt = -\int_0^t V_{in} \frac{dt}{R_{in} \cdot C}$$

To simplify the math's a little, this can also be re-written as:

$$V_{out} = -\frac{1}{j\omega RC} V_{in}$$

Where:  $\omega = 2\pi f$  and the output voltage  $V_{out}$  is a constant  $1/RC$  times the integral of the input voltage  $V_{IN}$  with respect to time.

Thus the circuit has the transfer function of an inverting integrator with the gain constant of  $-1/RC$ . The minus sign ( - ) indicates a  $180^\circ$  phase shift because the input signal is connected directly to the inverting input terminal of the operational amplifier.

### 8.9.4 Op-amp Differentiator Circuit

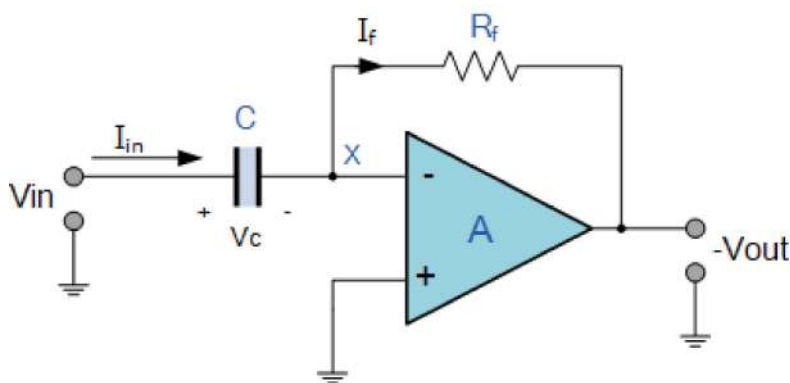

The input signal to the differentiator is applied to the capacitor. The capacitor blocks any DC content so there is no current flow to the amplifier summing point, X resulting in zero output voltage. The capacitor only allows AC type input voltage changes to pass through and whose frequency is dependant on the rate of change of the input signal.

At low frequencies the reactance of the capacitor is “High” resulting in a low gain (  $R_f/X_c$  ) and low output voltage from the op-amp. At higher frequencies the reactance of the capacitor is much lower resulting in a higher gain and higher output voltage from the differentiator amplifier.

However, at high frequencies an op-amp differentiator circuit becomes unstable and will start to oscillate. This is due mainly to the first-order effect, which determines the frequency response of the op-amp circuit causing a second-order response which, at high frequencies gives an output voltage far higher than what would be expected. To avoid this the high frequency gain of the circuit needs to be reduced by adding an additional small value capacitor across the feedback resistor  $R_f$ .

Since the node voltage of the operational amplifier at its inverting input terminal is zero, the current,  $i$  flowing through the capacitor will be given as:

$$I_{in} = I_f \text{ and } I_f = -\frac{V_{out}}{R_f}$$

The charge on the capacitor equals Capacitance times Voltage across the capacitor

$$Q = C \times V_{in}$$

Thus the rate of change of this charge is:

$$\frac{dQ}{dt} = C \frac{dV_{in}}{dt}$$

But  $dQ/dt$  is the capacitor current,  $i$

$$I_{in} = C \frac{dV_{in}}{dt} = I_f$$

$$-\frac{V_{out}}{R_f} = C \frac{dV_{in}}{dt}$$

From which we have an ideal voltage output for the op-amp differentiator is given as:

$$V_{out} = -R_f C \frac{dV_{in}}{dt}$$

Therefore, the output voltage  $V_{out}$  is a constant  $-R_f \times C$  times the derivative of the input voltage  $V_{in}$  with respect to time. The minus sign (-) indicates a  $180^\circ$  phase shift because the input signal is connected to the inverting input terminal of the operational amplifier.

One final point to mention, the **Op-amp Differentiator** circuit in its basic form has two main disadvantages compared to the previous operational amplifier integrator circuit. One is that it suffers from instability at high frequencies as mentioned above, and the other is that the capacitive input makes it very susceptible to random noise signals and any noise or harmonics present in the source circuit will be amplified more than the input signal itself. This is because the output is proportional to the slope of the input voltage so some means of limiting the bandwidth in order to achieve closed-loop stability is required.

### Op-amp Differentiator Waveforms

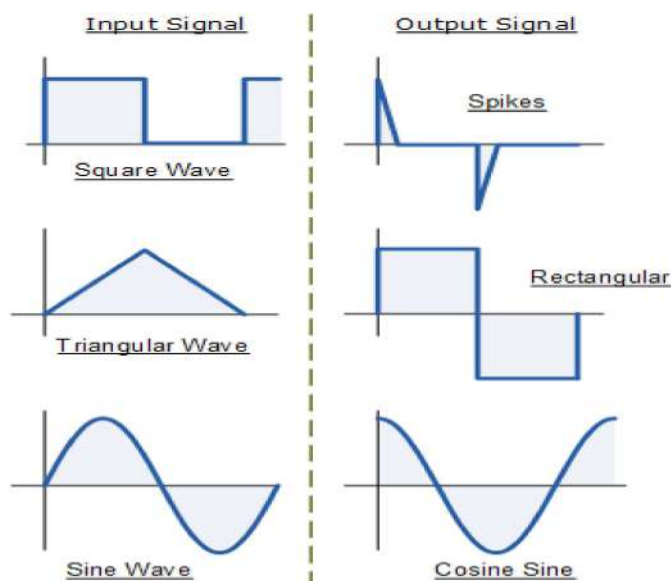

## 8.9.5 Op-amp Comparator Circuit

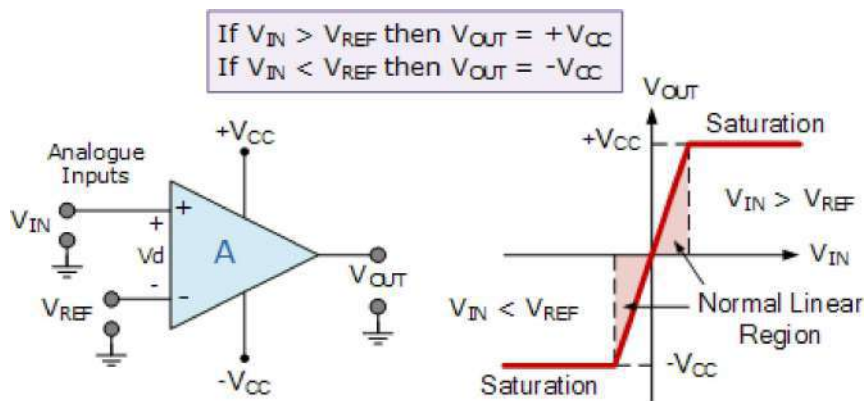

With reference to the op-amp comparator circuit above, let's first assume that  $V_{IN}$  is less than the DC voltage level at  $V_{REF}$ , ( $V_{IN} < V_{REF}$ ). As the non-inverting (positive) input of the comparator is less than the inverting (negative) input, the output will be LOW and at the negative supply voltage,  $-V_{CC}$  resulting in a negative saturation of the output.

If we now increase the input voltage,  $V_{IN}$  so that its value is greater than the reference voltage  $V_{REF}$  on the inverting input, the output voltage rapidly switches HIGH towards the positive supply voltage,  $+V_{CC}$  resulting in a positive saturation of the output. If we reduce again the input voltage  $V_{IN}$ , so that it is slightly less than the reference voltage, the op-amp's output switches back to its negative saturation voltage acting as a threshold detector.

Op-amp voltage comparator is a device whose output is dependent on the value of the input voltage,  $V_{IN}$  with respect to some DC voltage level as the output is HIGH when the voltage on the non-inverting input is greater than the voltage on the inverting input, and LOW when the non-inverting input is less than the inverting input voltage. This condition is true regardless of whether the input signal is connected to the inverting or the non-inverting input of the comparator.

The value of the output voltage is completely dependent on the op-amp's power supply voltage.

$$V_{OUT} = +V_{CC} \text{ or } V_{OUT} = -V_{CC}.$$

The basic op-amp comparator produces a positive or negative voltage output by comparing its input voltage against some preset DC reference voltage. Generally, a resistive voltage divider is used to set the input reference voltage of a comparator, but a battery source, Zener diode or potentiometer for a variable reference voltage can all be used as shown.

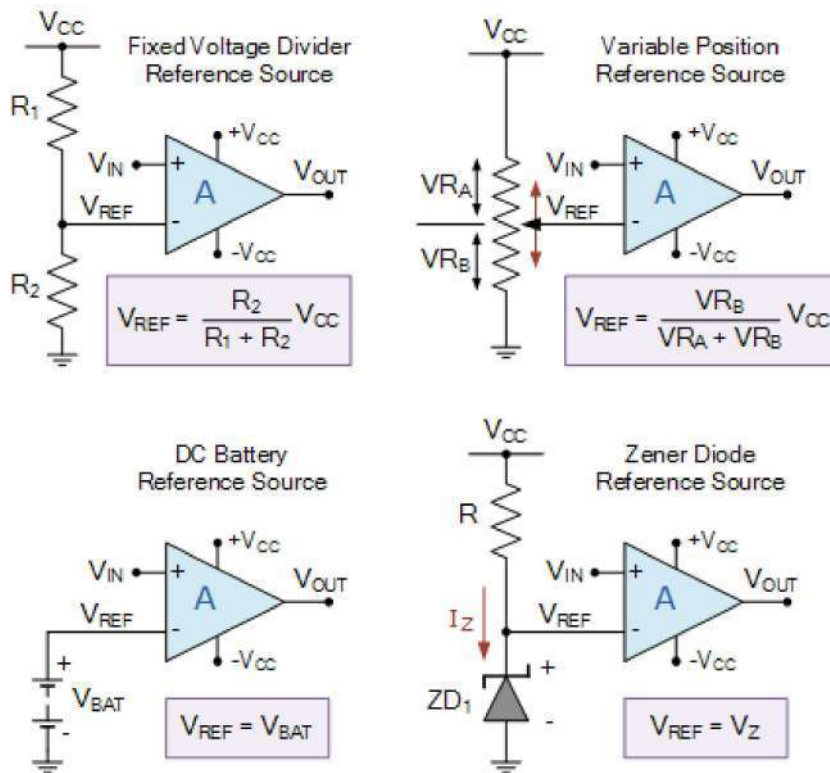

## Comparator Reference Voltages

In theory the comparators reference voltage can be set to be anywhere between 0v and the supply voltage but there are practical limitations on the actual voltage range depending on the op-amp comparator being device used.