

**COMPUTER
HARDWARE
&
MAINTENANCE**

CONTENTS

COMPUTER SYSTEM MANAGEMENT PLANNING.....

Need of Management in Computer Centers.....	
Types of Job Carried Out in Computers in an Organization.....	
Duties and Responsibilities of personnel involved.....	
Position of Different Levels.....	
Need of training staff.....	
Computer manufacture and installations in India.....	
Major vendors in computer hardware and software.....	

SITE PREPARATION & INSTALLATION.....

Plan for Computer Room layout based on Size.....	
Layout Factors and their effect.....	
Computer Centre Designs: Physical Computer Centre Setup.....	
Power Conditioning Equipment.....	
CVT (Constant Voltage Transformer).....	
Uninterruptible power supply (UPS).....	
Isolation Circuits.....	
Interpretation of the Installation and Wiring Diagram.....	
Steps for actual installation as per the manufacturer's Specified procedure..	

MOTHER BOARD & COMPONENTS

Introduction.....	
Hardware-BIOS interaction.....	
Interconnection between subsystems of PC.....	
System Unit.....	
Mother board.....	
SMPS (Switched Mode Power Supply).....	

HDD (Hard disk drive) System Interfaces.....	
Partitioning and formatting HDD.....	
Different Standards of Expansion Units ISA, EISA, VESA, PCI.....	
The Post Sequence (Power-On Self-Test).....	
Keyboard Interface.....	
Steps for assembling of a computer.....	
Software settings of computer after installation (CMOS-setup).....	

Maintenance and Trouble Shooting

Basic maintenance concepts.....	
Preventive Maintenance.....	
Corrective Maintenance.....	
On-line Maintenance.....	
Type & nature of fault.....	
Diagnostic program and tools.....	
Give Firmware (POST) concepts.....	
Fault elimination process.....	
Systematic way of trouble shooting versus adhoc trouble shooting.....	
Symptom observation.....	
symptom analysis.....	
fault diagnosis.....	
Fault Rectification.....	

Networking Devices and their interfacing

Network Interfacing Card.....	
Networking Interconnection Devices.....	
Hub.....	
Switch.....	
Router.....	
Types of Network Cable.....	
Types of Network Connector.....	
Appendix A: VI/SEM/CSE/2016 (W) New question paper.....	

1.1 Need of Management in Computer Centers

Normally, all computer centers are responsible for virtually similar tasks in all organizations, however, their focuses may not be the same.

The computer center, one of the support departments in the college, offer a wide range of services to satisfy the general computational and information processing needs of the educational, research and administrative programs. Services Provided by Computer Center are

- To provide computer-related services to personnel and customers
- To provide advice and consultancy for users
- To provide systems development services to users
- To provide data entry services for users
- To create and maintain IT standards and procedures
- To provide IT acquisition services to users
- To keep and protect IT and data assets
- To ensure that the organization has adequate/advanced IT progress, which is in line with the organization's vision
- To ensure that services provided are meeting with users' requirements

1.2 Types of Job Carried Out in Computers in an Organization

- Providing computing capability, running programs and producing reports, printing documents, providing operations services, make sure that good performance is provided
- Providing Internet services: Set up Internet and Email accounts, managing mailbox, providing disks spaces for Web, providing security and virus warning, etc.
- Providing helps: Help users to solve computer usage problems, help users to develop simple applications, help users to keep their data, help on security
- Providing system development services: Develop system for users
- Providing data entry services: This is to capture data into the systems, during these days, such function seems to be obsolete now. Such services may include storing data in database, data protection by data backup and recovery. Scanning images into the systems is also considered as a part of this function.
- Providing consultancy services: Purchasing devices, installing hardware & software, help users to work more efficiently
- Providing training for users, recently, the use of e-Learning concept of training also implemented

1.3 Duties and Responsibilities of personnel involved

Duties and responsibilities of person in computer centers are describe here

- Data Processing Center: To process business data (Sales, Deposit/Withdrawal, Airline Ticketing, Student Registration, etc.) and produce summary report or other business documents
- MIS Center: To provide information for managers and executives for making timely and quality decisions (usually continuing the work of data processing.
- Data Center: To provide data for use by all departments (e.g. center to provide criminal records, population records (Khonthai.com), etc.)
- Office Automation and Internet Center: To provide services to all departments with office automation and communication systems.
- Computing Service Center (or Computer Center or IT Service Center): Basically, to provide services of all types related to business data processing, business applications, and maintenance services to all departments in the organization.

In the department various staff with different computer skills is being employed. The data processing manager is the head of the department under which you have the computer analyst, programmer, operation manager, etc. There is probably no standard structure for data processing department. Precise responsibilities and reporting procedures vary. Figure 1 and 2 show some alternatives.

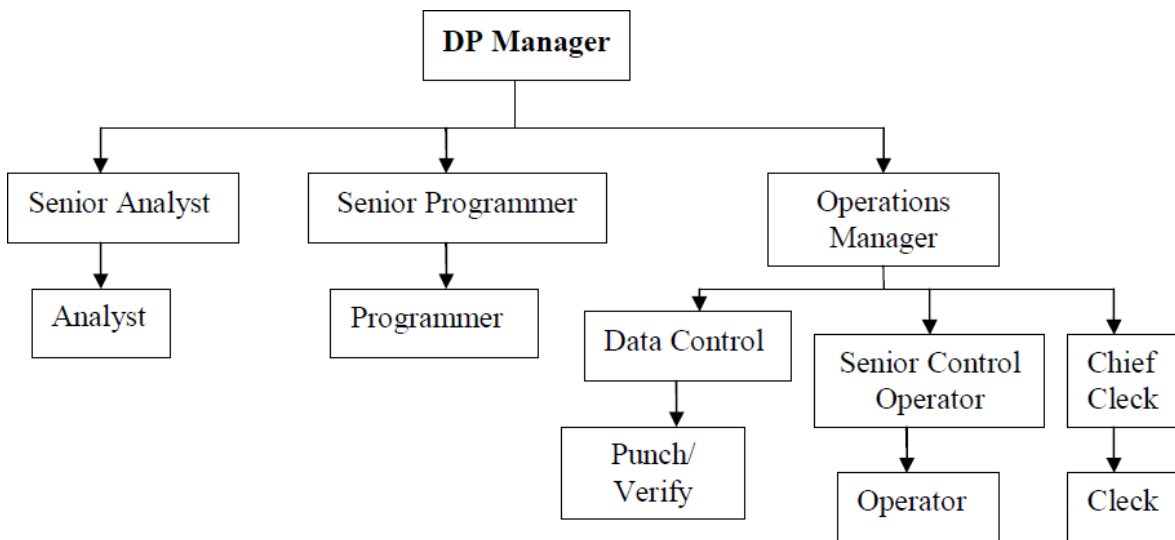

Figure 1 DP Department Structure I

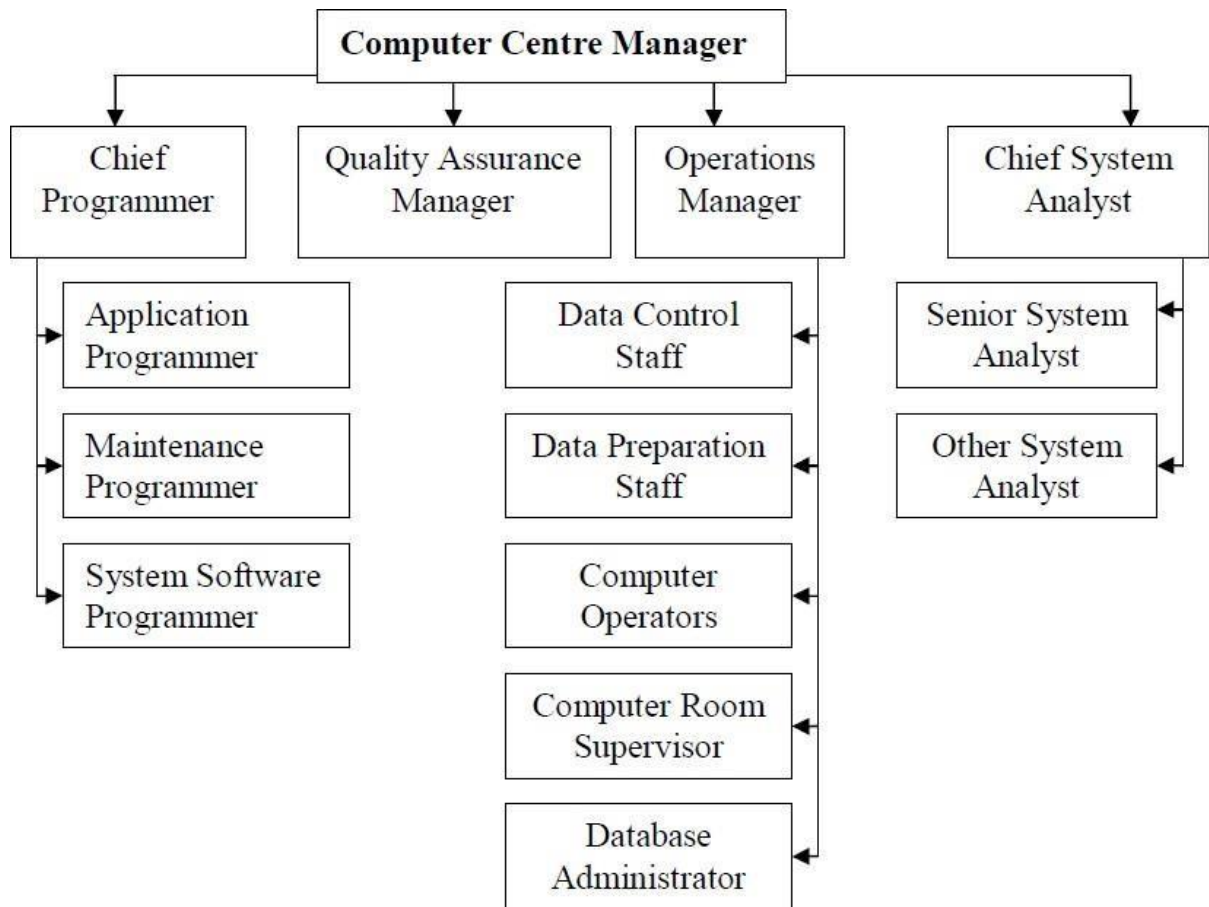

Figure 2: DP department Structure II

1.4 Position of Different Levels

(i) Computer Center must announce the service level policies on:

- Operating Labor
- Uptime
- Time to repair
- Response time

(ii) Objectives are to collect data about the usage & performance. Evaluate whether the performance is acceptable. If not, find out the problems and change the configurations, change the system software, recognize the disks, etc.

(iii) Prepare reports to the top management

(iv) System programmer is in charge of these tasks

A steering committee must be appointed for a fairly high-level control of the planning. The compositions are: the most senior executive of the company's the chairman, the manager of the computer department, a representative from the computer manufacturer, and other representative from the various departments within the company.

1.5 Need of training staff

- Due to the rapid growth of educational institutions there is an endemic shortage of good teachers. A big increase in the output of Masters and PhDs, particularly in Computer Science, is required.

- A large number of faculty positions in the Universities and engineering colleges and even in the IITs are vacant due to the dearth of persons interested in becoming academics. Encouragement in terms of good working conditions and emoluments are needed to attract competent faculty

- R and D spending of the Indian software services companies is relatively low. To go up the value chain IT companies have to innovate and invest in focused research. The reduction of cost of communication gave birth to the -offshore| software development model. The recent emergence of the -Computing Cloud| should lead to the next step, namely, providing Software as a Service (SaaS). The rich experience gained in the international market of offering software services should be leveraged to create world class -service products| from India on the -Cloud|

- Product companies need, besides an innovative product, huge investment, marketing, and the willingness to take risks. A company which was initially successful in selling FORTRAN compilers in a protected market in India went bankrupt as soon as imports were allowed as the imported product which had a worldwide market sold compilers at less than half the price of the local product. One of the few notable successes as a 6l product company in India is TALLY which produced accounting software in 1980. It succeeded as the software was designed keeping in view the accounting practices in India. It was affordable to a large number of small and medium enterprises. This provided the volume essential to amortize the development cost of the product. TALLY was able to continually improve its product by getting feedback from its local users. No foreign competitor understood the nuances of the local accounting practices or could match the price. So training of staff must require for running the TALLY software.

The committee should be given specifies terms of reference. There are obviously two choices open to management. They can recruit experience personnel and thus reap the benefit of that experience or they can re-train existing staff in computer techniques. In doing this, a number of factors used to be considered or the advantages and disadvantages of each option.

(a) Recruitment of Experience Personnel Advantages

- (i) Benefit of the experience.
- (ii) Little or no computer training required.

Disadvantages:

- (i) Demand exceeds supply, therefore high salary levels.
- (ii) No knowledge of company perhaps even industry.
- (iii) No company loyalties.
- (iv) Problem of interaction with existing staff.
- (v) Gamble of recruiting an unknown person.

(b) Re – Training of Present Staff

Advantages:

- (i) Retain existing loyalties.
- (ii) No need to spend time in teaching company operation
- (iii) Personality and ability already known.
- (iv) Acceptance to existing staff (assuming right people selected).

Disadvantages:

- (i) Computer training necessary.
- (ii) Over familiarities with the way thing are done and reluctant to change the present methods.

1.6 Computer manufacture and installations in India

There was no government policy on computers. As part of the five year plans higher technical education was promoted and five Indian Institutes of Technology and 13 Regional Engineering Colleges, one in each state, were established. The Directorate General of Technical Development and the Department of Defence Supplies controlled the area of computers. Foreign companies were permitted to manufacture and sell computers provided foreign exchange was not required. Computers were not considered a priority area that deserved foreign exchange outflow. IBM of the USA and the British Tabulating Machines (which was later named International Computers Ltd., ICL) were already selling mechanical unit record equipment, namely, key punches, verifiers, sorters, tabulators and accounting machines to a large number of companies, the Indian Railways, and statistics departments.

Before a computer is received at the user's premises the data processing manager must give many man- hours of thought to the preliminaries and must draw up detailed plans for the three major phases,

- Pre installation
- Installation and
- Productive running

Beside, there are also

- (i) Detailed planning (sitting, systems and programming, staffing etc) and
- (ii) Policy planning (The definition of objectives, budgeting and resources allocation)

All company's personnel must be involved for successful installation of computer system.

1.7 Major vendors in computer hardware and software

3. Site Preparation and installation

3.1 Plan for Computer Room layout based on Size

The environmental conditions of a computer are important to trouble-free running. All necessary conditions must be met before installation exercise. The layout of the computer room should be design with work flow in mind as we have in figure 4 below:

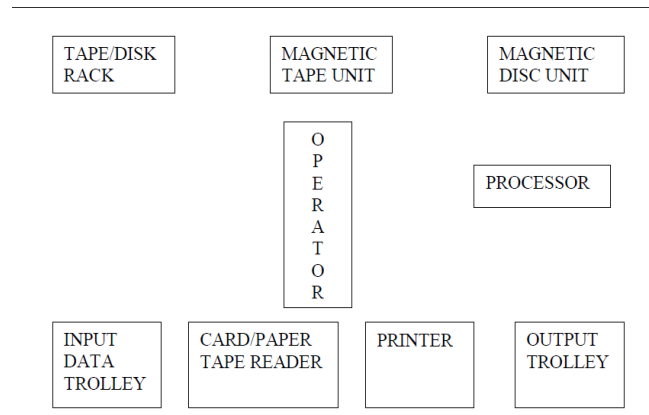
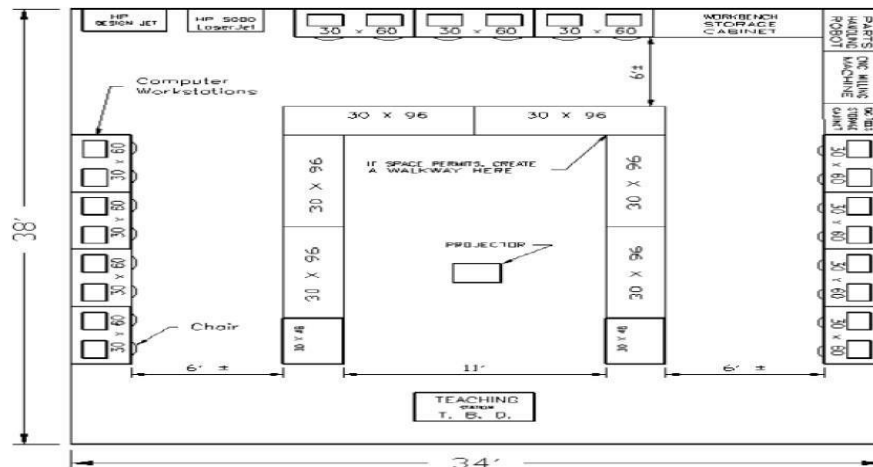

Figure 4: Computer Room Layout

The operator should be near to the input and output units which are most in use e.g. card or tape reader, printer, and tape or disc unit. The room must have air condition used for dust filtration, temperature control and humidity control.



3.2 Layout Factors and their effect

Depending on the type of computer centre, certain factors have to be considered when installing computer system. The factors are:

- a) **Local Support:** It is important to discover the level of support available locally from different manufactures of hardware. In most cases, the availability of such support would be a major factor in preferring a particular make of machine, even if initial cost are higher.
- b) **Hardware Security:** Physical security around computer centres and laboratories need to be

stepped up because of the activities of looters. Security attention should be given to the computer hardwares because of their small sizes; if the physical security is slack valuable and costly component of the system might be lost.

c) **Dust: It** is almost always advisable to provide dust cover on computer equipment when not in use, and in some areas special dust filters may be needed to prevent dust penetrating the casing.

d) **Heat:** Because of the heat been produced by the computer, full air conditioned office is highly imperative. It is advisable to buy portable air condition unit or install cooling fan in micro itself.

e) **Power Supply:** Computers can not function without electricity. Electric generators must be provided at the centre incase of the public power supply failure. In addition, the generator should be supported with power stabilizer and uninterruptible power supply (UPS). Power stabilizer protect the computer the harmful effects of fluctuations while UPS maintain the continuity of power supply in the gap between the switch over public supply to in- house generator or vise – versa.

f) **Humidity:** An unusually assemble of humidity can also be a problem, leading to corrosion of electric contact; it may be advisable to use non- corrodible plugs and socket or to use a contact less keyboard for example.

g) **Accessories:** It is essential to have a supply of computer accessories and part of a micro and all peripheral equipments.

h) **Workshop:** Basic maintenance facilities will be needed. It is not necessary to be an electronic engineer to do routine maintenance such as disc head alignment, to change board in the computer, or to run the diagnostics programs which will at least help to locate a fault.

i) **Communication Facilities:** These facilities must be provided to provide a link between the main computer centre and its terminals.

j) **Space Requirement:** From 400sq. ft. to several hundred thousand sq. ft; length-to-width ratio should be approximately 2:3; no long, narrow rooms.

k) **Floor loading:** should be sufficient, preferably with a sound-absorbent and antistatic covering.

h) **Workshop:** Basic maintenance facilities will be needed. It is not necessary to be an electronic engineer to do routine maintenance such as disc head alignment, to change board in the computer, or to run the diagnostics programs which will at least help to locate a fault.

i) **Communication Facilities:** These facilities must be provided to provide a link between the main computer centre and its terminals.

j) **Space Requirement:** From 400sq. ft. to several hundred thousand sq. ft; length-to-width ratio should be approximately 2:3; no long, narrow rooms.

k) **Floor loading:** should be sufficient, preferably with a sound-absorbent and antistatic covering.

3.2.1 Computer Centre Designs: Physical Computer Centre Setup

1. Site Selection

2. Designing office and rooms

3. Designing the whole centre

4. Detailing the facilities

. Raised floor: let the wind blow under the floor

. False ceiling

Air conditioner

Smoke and heat detectors

Rooms to be designed

- Machine room
- Operator working area
- Storage for paper, tapes, disks and outputs
- Customer engineer working area
- Technician area
- System development areas: for system analysts and programmers
- Library: for storing books, journals and software
- Conference and meeting rooms
- Training rooms
- Director rooms
- Secretary rooms
- Operator and guest areas
- Toilet
- Rest rooms
- Areas for storing power units and air conditioners: such areas are needed to be designed so that there will be no harm in case of power supply shortage.
- Separation into air-conditioned and non air-conditioned areas
- Floor preparation for equipment installation in the air condition areas
- Quiet zone in personnel areas (management offices, system support, operations scheduling, visiting programmers, library, conference room, coffee room).
- Solid and soundproof walls (over 40 dB in passage ways to separate air conditioned from non air-conditioned and noisy from quiet areas)
- Extensive use of moveable walls to allow for ongoing adjustments to technical and task-related developments
- Important features of a power supply to consider when purchasing it are its form factor, wattage capacity, number and type of connectors it provides, fan size, support for dual video cards, and warranty. To decide on the wattage capacity of a power supply, add up the wattage requirements for all components in a system and then increase that total by about 30 percent.
- False flooring: A raised floor (also raised flooring, access floor(ing), or raised access computer floor) provides an elevated structural floor above a solid substrate (often a concrete slab) to create a hidden void for the passage of mechanical and electrical services.

3.3 Power Conditioning Equipment

A power conditioner (also known as a line conditioner or power line conditioner) is a device intended to improve the quality of the power that is delivered to electrical load equipment. While there is no official definition of a power conditioner, the term most often refers to a device that acts in one or more ways to deliver a voltage of the proper level and characteristics to enable load equipment to function properly. In some uses, power conditioner refers to a voltage regulator with at least one other function to improve power quality (e.g. power factor correction, noise suppression, transient impulse protection, etc.). A good quality power conditioner is designed with internal filter banks to isolate the individual power outlets or receptacles on the power conditioner. This eliminates interference or "cross-talk" between components. Power conditioners vary in function and size, generally according to their use. Some power conditioners provide minimal voltage regulation while others protect against six or more power quality problems.

3.3.1 Constant Voltage Transformer

With the popularization of PCs, the constant voltage transformers (CVTs) have also become equally popular. The CVT is simply a magnetic transformer of a special construction that has a capacitor connected across the secondary winding of the transformer. In an ordinary transformer, the primary and secondary windings are wound near each other so that whenever there is a

change of voltage across the primary there is a corresponding change in the secondary voltage depending upon the ratio of the turns on the two windings. However, in a CVT the primary and secondary windings are wound separately from each other, as illustrated in figure. To set up field in between the coils, a separate shunt path is provided between the two windings but an airgap is formed in the shunt path. A capacitor is connected across suitable tapings of the secondary winding. The constructional details of a CVT are shown in the figure.

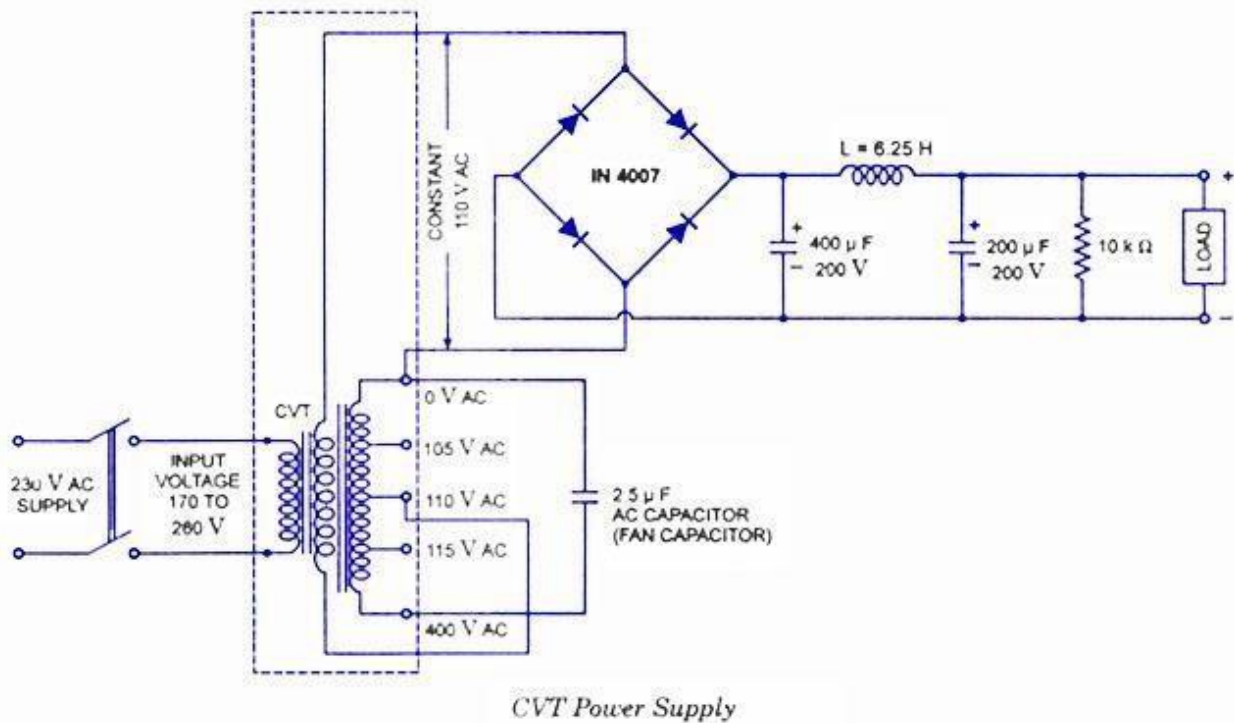

Sophisticated computer systems sometimes use diesel engine driven generators for backup in case of mains failure. Where our CVTs are used for power conditioning in the normal mains mode it is desirable to take advantage of the CVT performance when using the generator. These notes provide some guidance on the potential problems which can be met together with solutions.

Neutral

Some generators do not refer the low side of the output to earth. This MUST be tied down to avoid damage to any of our larger catalogue units which have double primary shields. Care must also be taken that the generator neutral is not connected to the CVT output low.

Frequency

All ferroresonant devices are frequency sensitive. The generator must run close to 50 Hz for the unit to operate correctly. Unfortunately the speed/output voltage curve for the generator goes the same way as the CVT so speed should be adjusted at actual running load. Short term off-frequency operation will not damage the CVT.

Phase

The output from the CVT will be out of phase with the input in cases where the generator supplies other equipment directly some care is needed if a phase sensitive triac firing circuit is installed.

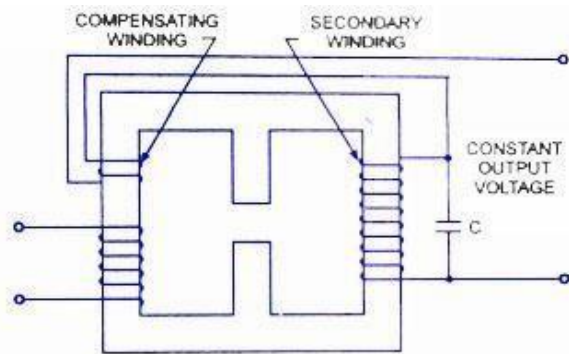

(a) Constructional Details

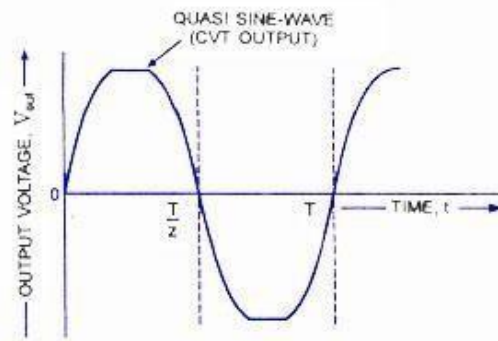

(b) Output Voltage Waveform

Safety

Unless phasing circuits are fitted all circuits should use 'break before make' contactors and enforced supply separation. Some thought needs to be given to the Regulations regarding out of phase supplies in the same area.

The reason we use a CVT and not a voltage stabilizer for computer applications is that in the voltage stabilizer relays are present and when these relays operate (switch), the output voltage may be interrupted for a short time. Such a transient may not be desirable for computers which may cause the computer to reboot. Also, the CVT provides a clean spike-free output voltage. The voltage regulation possible in a CVT also is good. The input voltage ranges 170 to 260 V and output regulation is $230 \pm 2\%$ at no load to full-load. Distortion—approximately 5% under full-load conditions. Rating of 50, 150, 250, 350, 500, 750, 1000, 2000 VA.

3.3.2 Uninterruptible power supply (UPS)

An uninterruptible power supply (UPS) is a device that allows a computer to keep running for at least a short time when the primary power source is lost. It also provides protection from power surges. A UPS contains a battery that "kicks in" when the device senses a loss of power from the primary source. If you are using the computer when the UPS notifies you of the power loss, you have time to save any data you are working on and exit gracefully before the secondary power source (the battery) runs out. When all power runs out, any data in your computer's random access memory (RAM) is erased. When power surges occur, a UPS intercepts the surge so that it doesn't damage the computer. Every UPS converts incoming AC to DC through a rectifier, and converts it back with an inverter. Batteries or flywheels store energy to use in a utility failure. A bypass circuit routes power around the rectifier and inverter, running the IT load on incoming utility or generator power. While UPS systems are commonly called double-conversion, line-interactive and standby designs, these terms have been used inconsistently and manufacturers implement them differently: At least one system allows any of the three modes. The International ElectroTechnical Commission (IEC) adopted more technically descriptive terminology in IEC Std. 62040. UPS systems are called dual or double conversion because incoming AC is rectified to DC to keep batteries charged and drive the inverter.

When electrical utility power fails or drops to an unacceptable level, Uninterruptible Power Systems (UPS) are key in saving and protecting valuable computer data. UPS equipment

provides power conditioning, power regulation and, in case of power outages, provides the crucial backup power needed for an orderly shutdown of computer processes and files. UPS are also used for emergency power supplies for Hospitals, data centers, municipalities, industrial and commercial centers to supply power in case of power failure from main supply authority.

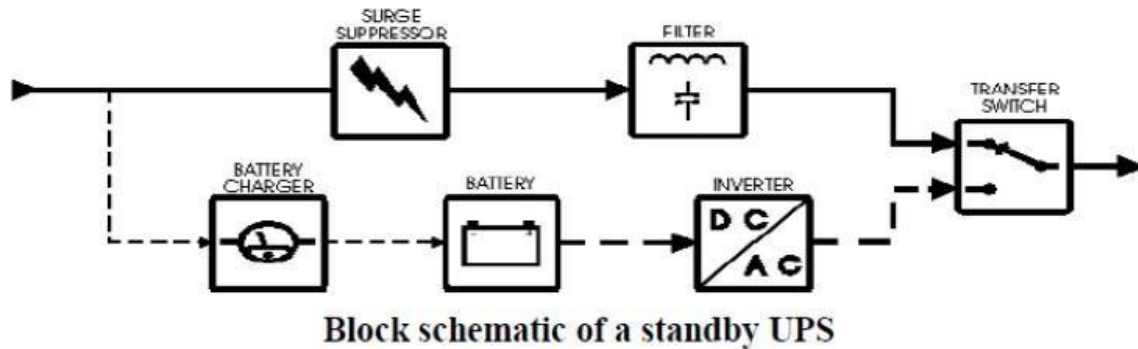
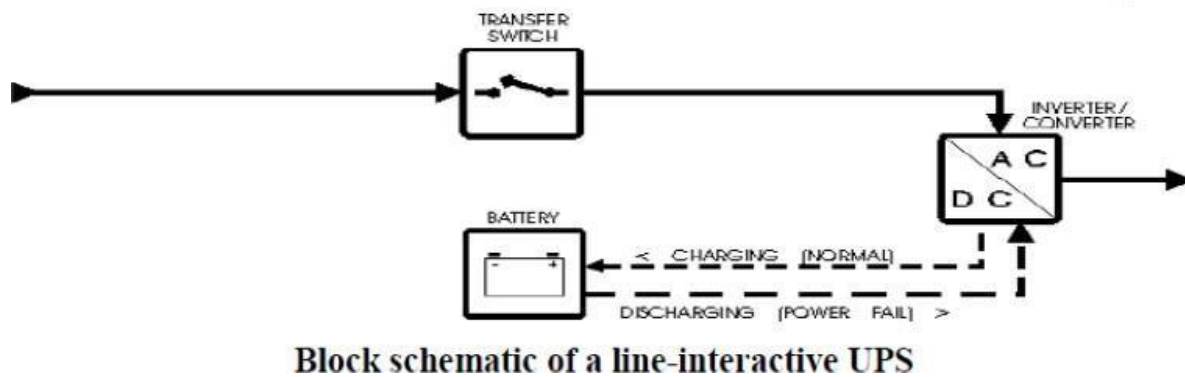
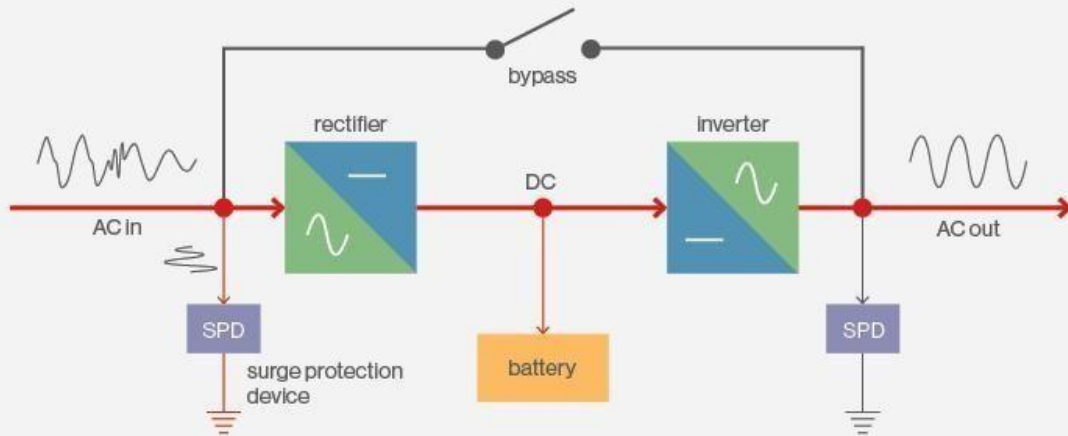

Figure 1



All UPS include core circuitry that manipulates electricity, converting it from the AC power produced by the utility company to DC power stored in the battery, and back again for use by your equipment via an inverter. The exact type, nature, size and quality of this circuitry depend on the type of UPS, and more specifically the make and model you have chosen. Most modern UPS are microprocessor-controlled. There is actually a small computer embedded within the UPS itself that controls the key functions of the UPS. This includes detecting AC power failures, handling switching between power sources, monitoring the status of the battery, controlling the status indicators and so on. These UPS are available for different Power output range such as: Standby UPS are usually available in a size range of up to about 1000 VA. The Line-interactive UPS is an improved design that is commonly used in units for home and business use, available in sizes up to 3,000 VA or so. It is superior to the standby UPS, but it still has a transfer time like standby UPS. Online UPS are typically used only for large servers, and for backing up multiple pieces of equipment in data centers. They are available in sizes from about 5,000 VA up to hundreds of thousands of VA and even larger. Ferro resonant standby UPS are usually available in a size range of up to about 15,000 VA, making them suitable.

FIGURE 5 A full-time double conversion UPS design under normal utility power.



The inverter re-creates steady AC power to run the IT equipment. When power fails the batteries drive the inverter, which continues to run the information technology (IT) load. When power is restored, either from the utility or a generator, the rectifier delivers direct current (DC) to the inverter and simultaneously recharges the batteries. The inverter runs full time. Utility input is completely isolated from the output, and bypass is only used for maintenance safety or if there's an internal electronics failure. Since there is no break in the power delivered to the IT equipment, vacuum fault interrupter (VFI) is generally considered the most robust form of UPS. Most systems synchronize the output frequency with the input, but that's not necessary, so it still qualifies as frequency independent. Every power conversion incurs a loss, so the wasted energy has historically been considered the price of ultimate reliability. The newest VFI systems claim better than 96% efficiency at nearly all loads.

The offline/standby UPS (SPS) offers only the most basic features, providing surge protection and battery backup. The protected equipment is normally connected directly to incoming utility power. When the incoming voltage falls below or rises above a predetermined level the SPS turns on its internal DC-AC inverter circuitry, which is powered from an internal storage battery. The UPS then mechanically switches the connected equipment on to its DC-AC inverter output. The switchover time can be as long as 25 milliseconds depending on the amount of time it takes the standby UPS to detect the lost utility voltage. The UPS will be designed to power certain equipment, such as a personal computer, without any objectionable dip or brownout to that device.

FIGURE 6: A dual conversion UPS design when utility power fails.

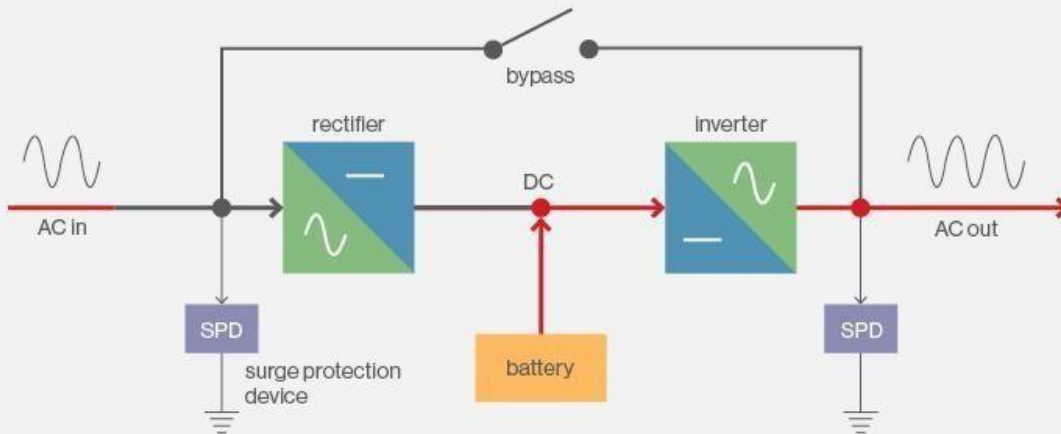

3.3.3 Isolation Circuits

Backbone to ensure highest availability of pure power depends on effective power distribution and its conditioning. Power distribution can be Achieve with help of panels, sockets, cables, Automatic transfer switch (ATS), Generator and PDU. While conditioning of power can be done with help of TVSS, K rated Isolation transformer, UPS etc. An isolation transformer is a transformer used to transfer electrical power from a source of alternating current (AC) power to some equipment or device while isolating the powered device from the power source, usually for safety reasons. Industrial electronic equipment commonly uses galvanic isolators to protect systems and users from potentially hazardous voltages. It is well known that industrial equipment must operate reliably in the harshest environments, where strong electromagnetic fields, surges, fast transients, and high noise floors are the norm. This environment presents challenges for designing reliable isolation circuits that deliver error-free operation over long equipment lifetimes. Over the last four decades, opt couplers have been the -default| signal isolation device, but recent breakthroughs in silicon isolation technology have spawned smaller, faster, and more reliable and cost-effective solutions that have already begun supplanting opt couplers in many end applications. This white paper discusses industrial isolation issues and ways RF isolation technology can be applied to increase system robustness and performance.

Benefits of isolator circuits include:

- Higher integration: smaller size and lower cost-per-channel on multi-channel versions
- Higher performance: faster, tighter timing and substantially lower power
- Longer service life: no wear-out mechanisms as in opt couplers
- Higher reliability: operating parameters remains table over VDD, temperature, and device age

- Easy to use: single-chip, complete isolation solution

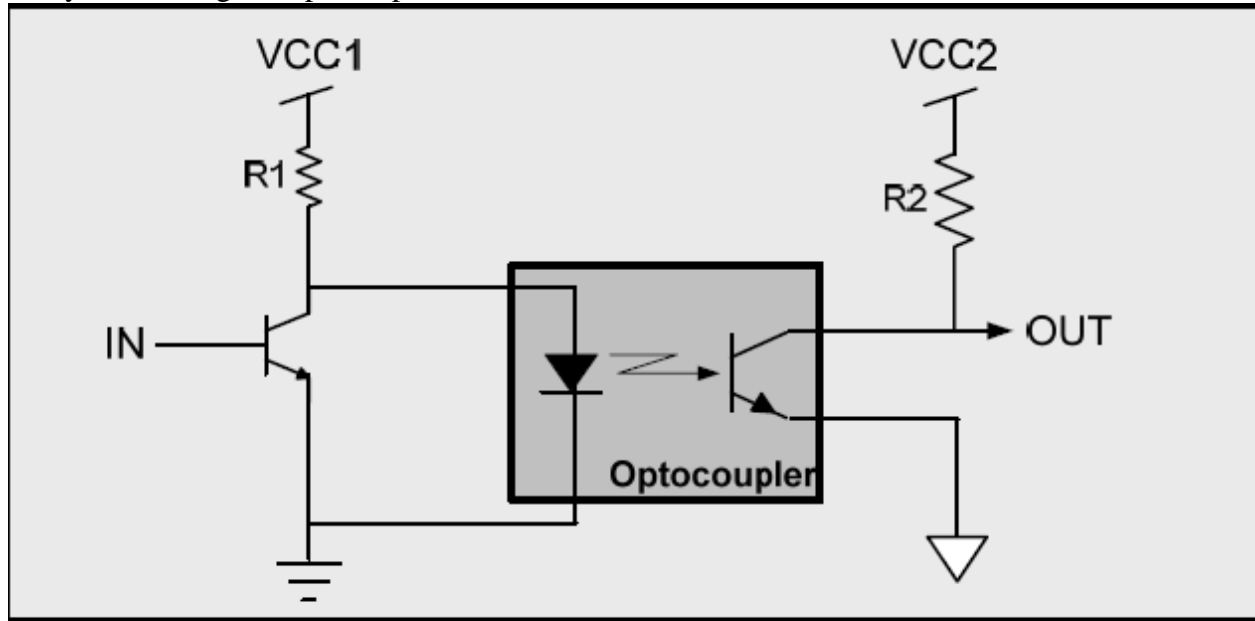

Figure 7). High CMTI Isolator

3.4 Interpretation of the Installation and Wiring Diagram

The first commercial computer to be installed in India was an IBM 1401 at ESSO Standard Eastern Inc., an oil marketing company in Mumbai. Between 1961 and 1964 twelve computers were installed in Research and Development organizations and two in educational institutions. Now-a-days for installation we required various types of tools. For example

Here is a list of essential tools:

- Ground bracelet, ground mat, or antistatic gloves to protect against ESD when working inside the computer case
- Flathead screwdriver Phillips-head or crosshead screwdriver
- Torx screwdriver set, particularly size T15
- Tweezers, preferably insulated ones, for picking pieces of paper out of printers or dropped screws out of tight places
- Extractor, a spring-loaded device that looks like a hypodermic needle (When you push down on the top, three wire prongs come out that can be used to pick up a screw that has fallen into a place where hands and fingers can't reach.)
- Software, including recovery CD or DVD for any OS you might work on (you might need several, depending on the OSs you support), antivirus software on bootable CDs or USB flash drives, and diagnostic software.

The following tools might not be essential, but they are very convenient:

- Cans of compressed air (see Figure 1-39), small portable compressor, or antistatic vacuum cleaner to clean dust from inside a computer case Cleaning solutions and pads such as contact cleaner, monitor wipes, and cleaning solutions for CDs, DVDs, tapes, and drives
- Multimeter to check cables and the power supply output
- Power supply tester
- Needle-nose pliers for removing jumpers and for holding objects (especially those pesky nuts on cable connectors) in place while you screw them in
- Cable ties to tie cables up and out of the way inside a computer case
- Flashlight to see inside the computer case
- AC outlet ground tester
- Network cable tester
- Loopback plugs to test ports
- Small cups or bags to help keep screws organized as you work
- Antistatic bags (a type of Faraday cage) to store unused parts
- Chip extractor to remove chips (To pry up the chip, a simple screwdriver is usually more effective, however.)
- Pen and paper for taking notes
- POST diagnostic cards

When building a new system, you can purchase a computer case with the power supply already installed or you can purchase a power supply separate from the case. Important features of a power supply to consider when purchasing it are its form factor, wattage capacity, number and type of connectors it provides, fan size, support for dual video cards, and warranty. To decide on the wattage capacity of a power supply, add up the wattage requirements for all components in a system and then increase that total by about 30 percent.

1. Unpack the monitor and computer case from the box. Remove any plastic covering or protective tape. Place the monitor and computer case on a desk or work area. Be sure to place your computer case in an area that is well ventilated and has good air flow. This will help to prevent the computer from overheating.
2. Locate the monitor cable.
3. Connect one end of the cable to the monitor port on the back of the computer case and the other end to the monitor.
4. Unpack the keyboard and determine whether it uses a USB (rectangular) connector or a PS/2 (round) connector. If it uses a USB connector, plug it into any of the USB ports on the back of the computer. If it uses a PS/2 connector, plug it into the purple keyboard port on the back of the computer.
5. Unpack the mouse and determine whether it uses a USB or PS/2 connector. If it uses a USB connector, plug it into any of the USB ports on the back of the computer. If it uses a PS/2 connector, plug it into the green mouse port on the back of the computer.
6. If you have external speakers or headphones, you can connect them to your computer's audio port (either on the front or back of the computer case). Many computers have color-coded ports. Speakers or headphones connect to the green port, and microphones connect

to the pink port. The blue port is the line in, which can be used with other types of devices. Some speakers, headphones, and microphones have USB connectors instead of the usual audio plug. These can be connected to any USB port. In addition, many computers have speakers or microphones built into the monitor.

7. Locate the two power supply cables that came with your computer. Plug the first power supply cable into the back of the computer case and then into a surge protector. Then, using the other cable, connect the monitor to the surge protector.
8. Finally, plug the surge protector into a wall outlet. You may also need to turn on the surge protector if it has a power switch.

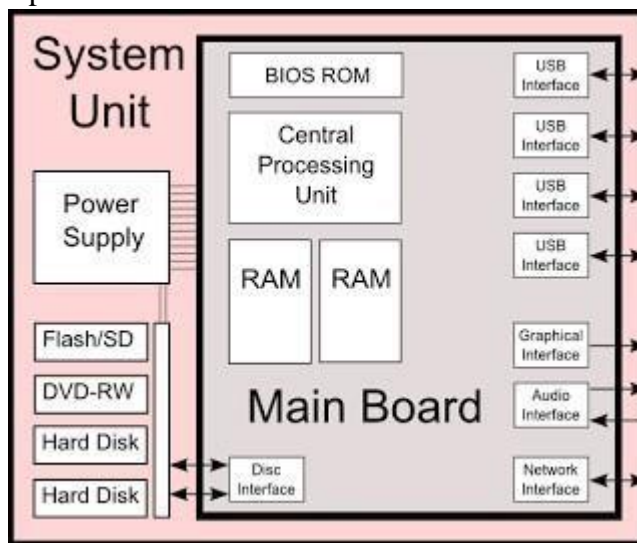

3.5 Steps for actual installation as per the manufacturer's Specified procedure

1. Computerized systems should be validated at the level appropriate for their intended use and in accordance with quality risk management principles. This applies to systems used in all good (anything) practices (GXP) activities (e.g. good clinical practice (GCP), good laboratory practice (GLP) and good manufacturing practices (GMP)
2. The purpose of validation of a computerized system is to ensure an acceptable degree of documented evidence that establishes confidence in the accuracy, reliability and consistency in performance of the system in accordance with predetermined specifications. The validation data should meet the principles of being attributable, legible, contemporaneous, original and accurate (ALCOA) throughout the data life cycle.
3. Computerized system validation should ensure that all necessary technical and procedural controls are implemented ensuring compliance with good documentation practices for electronic data generated by the system (WHO guidance on good data and record management practices, WHO Technical Report Series
4. System elements that need to be considered in computerized system validation include computer hardware and software, related equipment and network components and operating system environment, procedures and systems documentation including user manuals and people (such as, but not limited to, users, data reviewers, system application administrators, network engineers, database administrators and people involved in archiving). Computerized system validation activities should address both system configuration as well as any custom-developed elements.

5. Computerized systems should be maintained in the validated state with risk-based controls appropriate to the different stages of the system life cycle. These stages include system planning, specification, programming and configuration, system testing, preparation and verification of standard operating procedures (SOPs) and training programmers, system operation and maintenance including handling of software and hardware updates, monitoring and review, followed by system retirement.
6. Depending on the types of systems or typical applications such as process control systems (distributed control system (DCS), programmable logic controller (PLC), supervisory control and data acquisition (SCADA)), laboratory information management systems (LIMS), laboratory instrument control systems and business systems (enterprise resource planning (ERP), manufacturing resource planning (MRP II)) used by the manufacturer, a document covering (but not limited to) the following information should be available on-site:
 - purpose and scope;
 - roles and responsibilities;
 - validation approach;
 - risk management principles;
 - system acceptance criteria;
 - vendor selection and assessment;
 - computerized system validation steps;
 - configuration management and change control procedures;
 - back-up and recovery;
 - error handling and corrective action;
 - contingency planning and disaster recovery;
 - maintenance and support;
 - system requirement;
 - validation deliverables and documentation;
 - template, formats, annex; examples
7. A typical model for computerized systems validation is the V-model. The lifecycle development model (or V-model for short), is a framework or structure for undertaking the design, execution and commissioning of a design project (see also International Society for Pharmaceutical Engineering (ISPE) Baseline: a risk based approach to compliant GXP computerized systems GAMP). The left-hand edge of the V is where the project is defined and specified in greater detail. The bottom point of the V is the execution step of the project. The right-hand edge of the V is where the commissioning and qualification testing of the installed system is performed. The V-model provides a logical sequence that helps to organize the complex activities of defining a project scope, executing it and qualifying it.

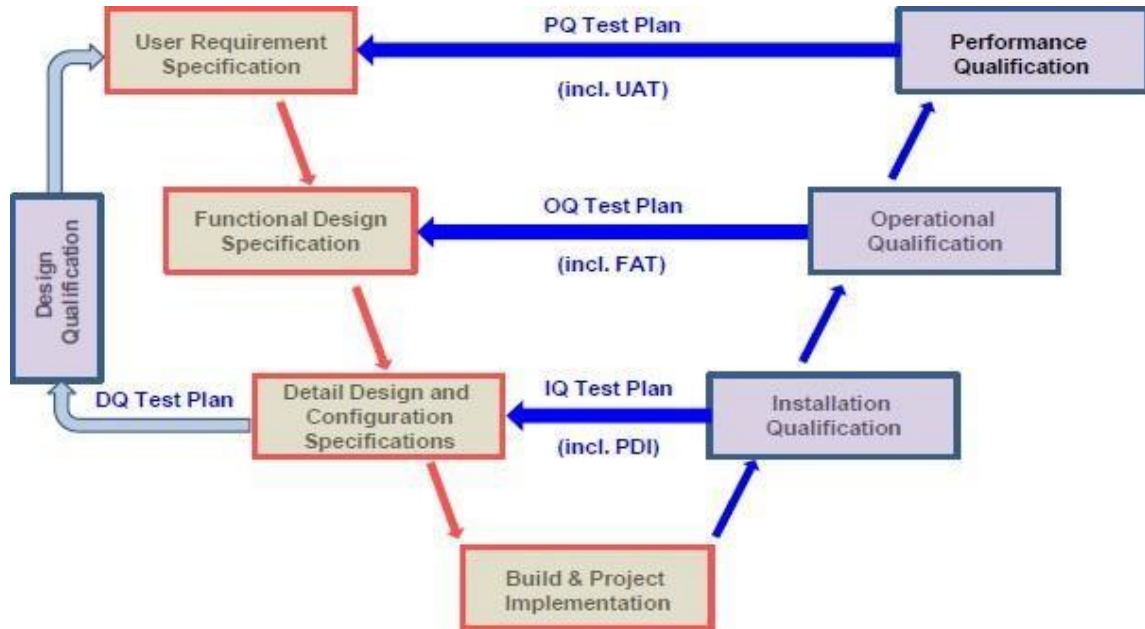
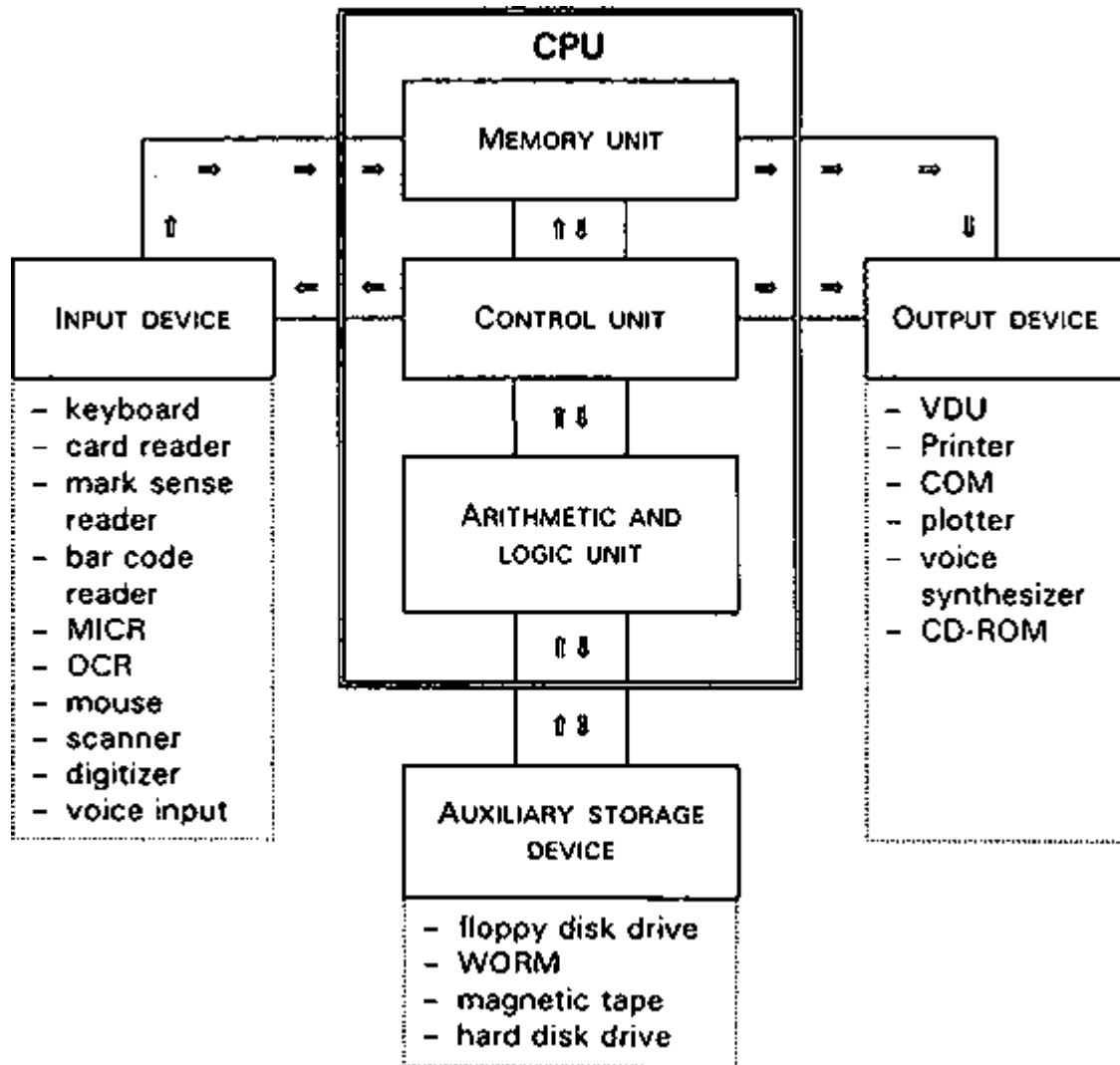

Figure 8 V-model

4. COMPONENTS INSIDE THE COMPUTERS (PC) & THEIR INTERCONNECTION

4.1 INTRODUCTION Computers store information digitally. All the information stored as numbers, in a binary system. A binary system has only two numbers 0 and 1. (Decimal system has 10 numbers 0. 9).



(a) The Central Processing Unit (CPU), also called a processor, is like the brain of the computer. It executes instructions in response to commands. processor's speed is measured in Megahertz (MHZ), or Gigahertz (GHZ) Higher the hertz, the faster the process in of instructions

(b) RAM (Random Access Memory) is also called main memory. RAM is used to store data and instructions that are currently being processed by a computer's CPU. Data is temporarily stored in the RAM till it is saved to the hard disk. The data in RAM is erased when power is switch off. RAM is measured in megabytes (MB) or gigabytes (GB). A bit is the smallest unit of data in computer processing. It represents a digit in the binary system. So a bit can have either a value 0 or value 1. A byte is a group of eight bits. A Kilobyte (KB) is 2^{10} bytes or approximately 1024 bytes. A Megabyte (MB) is about one million bytes. A gigabyte (GB) is 1,024 megabytes. The

more RAM a computer has, the more things a computer can access at the same time. So more the RAM, the faster a computer performs tasks.

(c) Secondary storage is where the information is stored permanently till explicitly deleted. Information is moved between main memory and secondary memory as and when needed. Power off of a computer, data on hard disk and other secondary storage devices is not erased. The hard disk drive is the data center of the computer. Operating system, software, content (created and saved by users) are stored here until explicitly deleted. The hard disk drive is usually found inside a computer. CD/DVD and pen drive are removable storage devices. These can be used to backup important data and information. They also sometimes used to distribute, share information or transfer information from one computer to another.

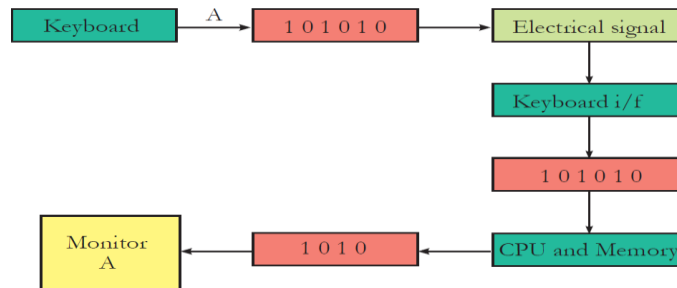

(d) An input device converts data and instructions entered using the device into a pattern of electrical signals. These signals correspond to binary code that can be processed by a digital computer. A user inputs data and instructions (Example: using a keyboard), initiates a task (Example: using a mouse), transfers images (example: using a web camera), using the input devices. An output device reverses the process, translating the digitized signals into a form intelligible to the user. The computer displays processed information (example: a print out of the information or audio, video) through the output devices. Keyboard, mouse, scanner, webcam are examples of input devices. Monitor, printer, speakers are examples of output devices. Some devices can handle both input and output. The network device (called network card) in a computer is both input and output device

4.2 Hardware-BIOS interaction

BIOS software and booting



Concept

- Basic input output system (BIOS) is the first software that runs on a computer when power.
- First task of BIOS is to initialize and identify devices such as the display card, keyboard, mouse, hard disk, CD/DVD drive and other hardware. Next task of the BIOS is to find the operating system software that is provided on a hard disk or a CD and load the operating system. BIOS then gives control of the computer to the OS. This process is known as booting.

Info

BIOS are usually stored on a Flash memory, an electronic chip on the motherboard. Flash memory provides fast, permanent storage and can be easily updated. Some of the other devices where is used are digital cameras, gaming devices.

The BIOS software has a number of different roles, but its most important role is to **load the operating system**. When you turn on your computer and the microprocessor tries to execute its first instruction, it has to get that instruction from somewhere. It cannot get it from the operating

system because the operating system is located on a hard disk, and the microprocessor cannot get to it without some instructions that tell it how. The BIOS provides those **instructions**. Some of the other common tasks that the BIOS performs includes:

1. A power-on self-test (POST) for all of the different hardware components in the system to make sure everything is working properly.
2. Activating other BIOS chips on different cards installed in the computer – e.g. SCSI and graphics cards often have their own BIOS chips.
3. Providing a set of low-level routines that the operating system uses to interface to different hardware devices - it is these routines that give the BIOS its name. They manage things like the keyboard, the screen, and the serial and parallel ports, especially when the computer is booting.
4. Managing a collection of settings for the hard disks, clock, etc.

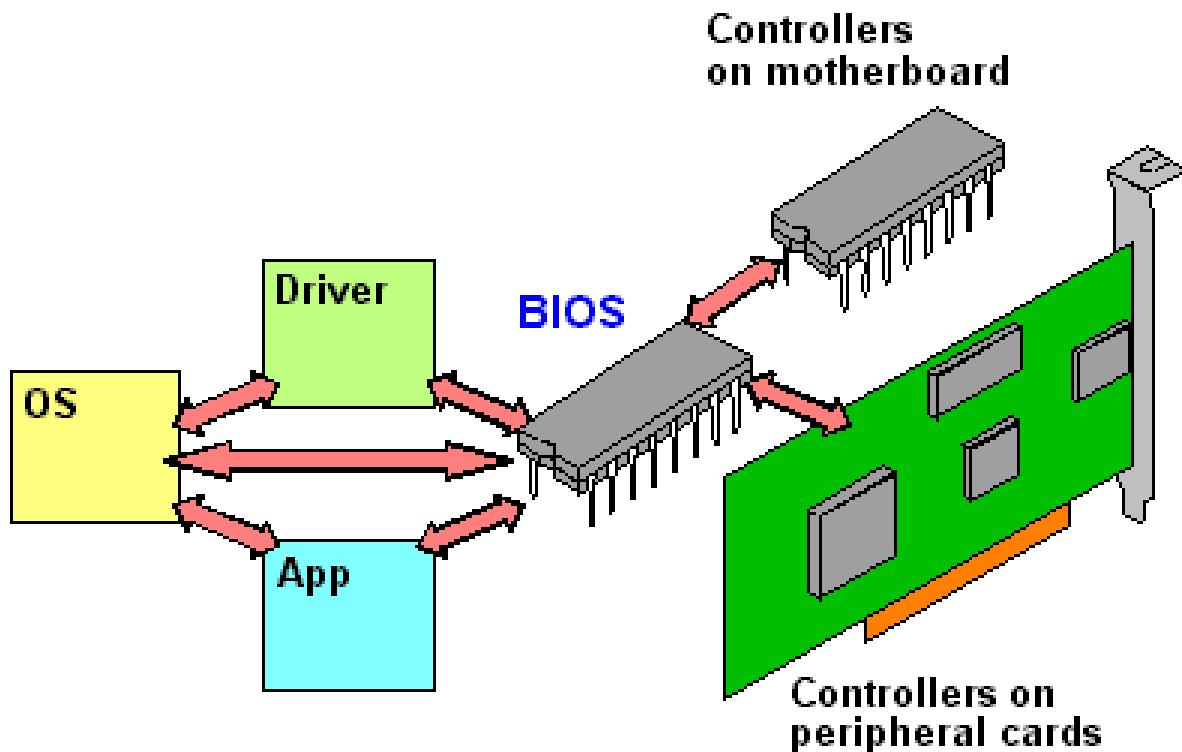

BIOS Interaction

The **BIOS** (an acronym for **Basic Input/output System** and also known as the **System BIOS**, **ROM BIOS** or **PC BIOS**) is a type of firmware used to perform hardware initialization during the booting process (power-on startup) on IBM PC compatible computers, and to provide runtime services for operating systems and programs. The BIOS firmware is built into personal computers (PCs), and it is the first software they run when powered on. The name itself originates from the Basic Input/output System used in the CP/M operating system in 1975. Originally proprietary to the IBM PC, the BIOS has been reverse engineered by companies looking to create compatible systems and the interface of that original system serves as a *de facto* standard. The fundamental purposes of the BIOS in modern PCs are to initialize and test the system hardware components, and to load a boot loader or an operating system from a mass memory device. The BIOS additionally provides an abstraction layer for the hardware, i.e., a consistent way for application programs and operating systems to interact with the keyboard,

display, and other input/output (I/O) devices. Variations in the system hardware are hidden by the BIOS from programs that use BIOS services instead of directly accessing the hardware. MS-DOS (PC DOS), which was the dominant PC operating system from the early 1980s until the mid-1990s, relied on BIOS services for disk, keyboard, and text display functions. MS Windows NT, Linux, and other protected mode operating systems in general ignore the abstraction layer provided by the BIOS and do not use it after loading, instead accessing the hardware components directly. Most BIOS implementations are specifically designed to work with a particular computer or motherboard model, by interfacing with various devices that make up the complementary system chipset. Originally, BIOS firmware was stored in a ROM chip on the PC motherboard; in modern computer systems, the BIOS contents are stored on flash memory so it can be rewritten without removing the chip from the motherboard. This allows easy updates to the BIOS firmware so new features can be added or bugs can be fixed, but it also creates a possibility for the computer to become infected with BIOS root kits.

4.3 Interconnection between subsystems of PC

The PC is a *system*, which means that it contains many different parts that work together to accomplish its various tasks. However, not all of the various components in the machine are connected together in the same way, or you could say, at the same level. There are some that are more centrally located and connected to more of the other pieces; there are others that are more "added on" to the central core of the machine. There are *subsystems* within the system that each do different jobs.

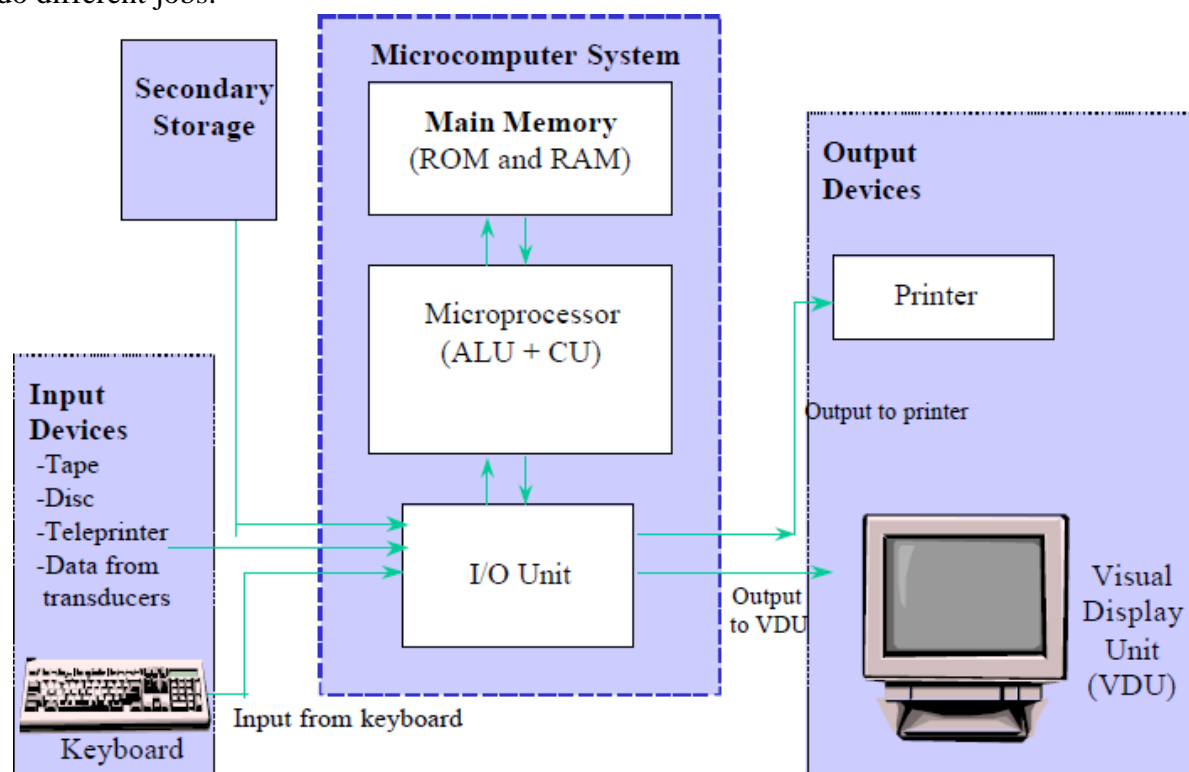

The subsystems each contain components that work together, and with the other subsystems of the PC. The heart of any PC is what I call the *system processing core*. This set of critical components forms the logical center of any PC, and is responsible for most of the key characteristics that make a system what it is. The system processing core includes the following components:

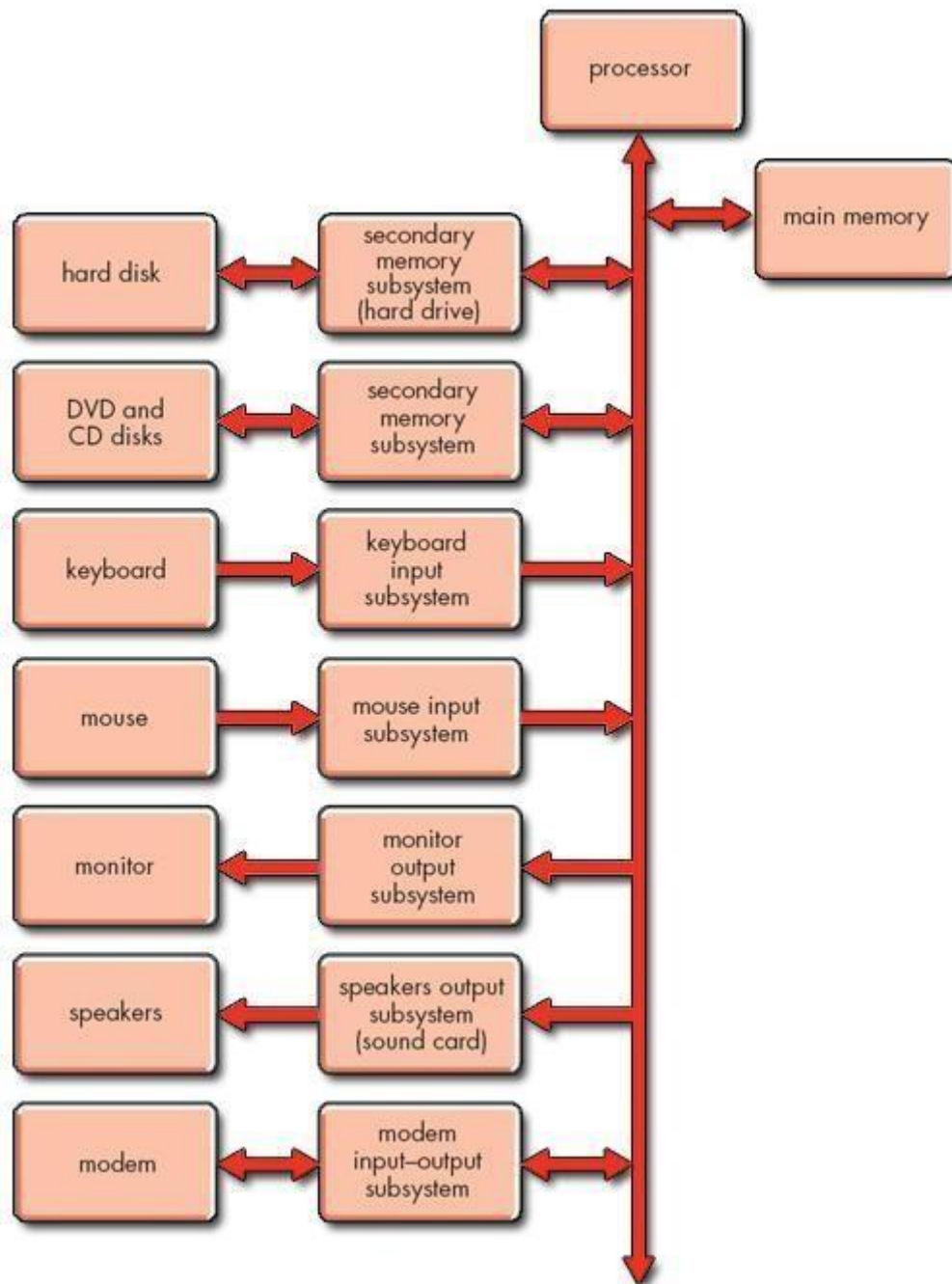

Figure 9 Functional block diagram for the PC

4.4 System Unit

- System processors (also called *central processing units* or *CPUs*).
 - Motherboards (along with their many constituent devices such as the chipset, system buses and so on).
 - System memory.
 - Video cards. (The video card is also part of the video subsystem, but on modern systems so much processing can be "offloaded" from the CPU to the video processor that it can in many ways be considered a core system device.)
- . The CPU is the component that processes instructions. It receives input from the computer's user, operates applications and the operating system and processes data to provide output.
- . RAM provides the operating memory for the computer. The more processes a computer needs to run at a single time, the more RAM it needs. Operating processes from RAM is much faster than running them from a disk or hard drive.
- . A computer's storage permits it to permanently store files and data. The hard drive is a common storage device that varies in capacity.

4.4.1 Mother Board

- Motherboard connects directly or indirectly to every part of the computer. The motherboard's main job is to hold the computer's microprocessor chip and let everything else connect to it.
- Everything that runs the computer or enhance its performance is either part of the motherboard or plugs into via a slot or port.
- The motherboard is the computer's main circuit board. It's a thin plate that holds the CPU, memory, connectors for the hard drive and optical drives, as well as various external ports and peripherals.
- A port is connected from inside to expansion cards which are plugged into the motherboard and are connected to other components by cables which are long, flat bands that contain electrical wiring. The ports are controlled through the expansion cards.

When a motherboard is considered a field replaceable unit, so it's important to know how to replace one, but the good news is you don't need to know how to repair one that is broken. A motherboard is the most complicated component in a computer. When you put together a computer from parts, generally you start with deciding on which processor and motherboard you will use. Everything else follows these two decisions. A micro ATX motherboard by Intel that can hold an Intel Core i7, Core i5, or Core i3 processor in the LGA1155 processor socket. When selecting a motherboard, generally, you'd need to pay attention to the form factor, processor socket, chipset, buses and number of bus slots, and other connectors, slots, and ports. In selecting the right motherboard when replacing an existing one or when building a new system is a challenging factor; so the types of slots on the motherboard and whether replacement parts will fit.

(a) CPU Slot

The CPU is often called the brains of a computer because it is the hardware that carries out instructions from software by using math, input/output commands and logic. The CPU slot (also known as a CPU socket) is where the processor is stored on a computer's motherboard. To replace a CPU you will need to raise the socket by lifting a small lever on the side of the socket; then you can gently pull out the CPU hardware. Replace the old CPU with a new one

by aligning your new CPU with the socket, gently placing it in (do not push) and then flipping the socket lever to secure it.

(b) RAM Slot

Random access memory (RAM) is data storage hardware on your computer's motherboard. Despite the name, RAM does not actually "remember" anything when a computer is turned off. Programs must be saved on the hard drive or another storage device. In practical terms, RAM determines how many programs can run at once and how large the programs can be. Computers cannot run without RAM installed. They often come packaged with multiple strips located in RAM slots on the motherboard that are easily removable and replaceable. Upgrading RAM will improve the speed of your computer.

(c) PCI Slot

The Peripheral Component Interconnect (PCI) slot is a slot for expansion devices. Most desktop computers come with several PCI expansion slots. PCI slots are used for a variety of devices: modems, network cards, television tuners, radio tuners, video cards and sound cards, among others. Most computers today have several of these cards already built in. For computers that do not, these expansion devices provide additional functionality to a computer, making it possible for essential functions in a business such as wireless Internet connectivity.

(d) PCI Express Slot

The PCI Express slot, like the PCI slot, is used for expansion cards. PCI Express allows for higher transfer speeds than PCI and is therefore preferred for graphics cards. The PCI Express has replaced the Accelerated Graphics Port (AGP) in most computers as the primary slot for graphics cards. Many newer programs, such as Adobe's popular photo and video editors, rely more on an advanced graphics card to process data. Upgrading your graphics card can improve performance markedly.

(e) Hard Drive Slots

To connect hard drives to your computer, you might find a group of small rectangular slots, called serial advanced technology attachment slots. Some SATA slots might be capable of higher speeds and are usually colored differently. Connect solid-state drives to the high-speed SATA slots and mechanical disk drives to the lower-speed slots. Older motherboards might have parallel advanced technology attachment slots. PATA slots resemble PCI and PCIe slots more than they resemble SATA slots. PATA slots connect to disk drives as well as CD and DVD recorders and players using a ribbon cable.

(f) Expansion slot

Alternatively referred to as a bus slot or expansion port, an expansion slot is connection or port located inside a computer on the motherboard or riser board that allows a computer hardware expansion card to be connected. For example, if you wanted to install a new video card in the computer, you'd purchase a video expansion card and install that card into the compatible expansion slot.

4.4.2 SMPS (Switched Mode Power Supply)

SMPS stands for switched mode power supply. It is an electronic device in which energy conversion and regulation is provided by power semiconductors that are continuously switching with high frequency between "on" and "off" states. An output parameter (usually output voltage) is controlled by varying duty cycle, frequency or a phase shift of these transitions. The SMPS (Switched Mode Power Supply) is different from a traditional power supplies because it can be used for different voltage inputs (from 80V to 300V AC). If the SMPS has an AC input, then its

first job is to convert the input to DC. This is called rectification. The rectifier circuit can be configured as a voltage doubler by the addition of a switch operated either manually or automatically. This is a feature of larger supplies to permit operation from nominally 120volt or 240volt supplies. The rectifier produces an unregulated DC voltage which is then sent to a large filter capacitor. The current drawn from the Mains supply by this rectifier circuit occurs in short pulses around the AC voltage peaks. These pulses have significant high frequency energy which reduces the power factor. Special control techniques can be employed by the following SMPS to force the average input current to follow the sinusoidal shape of the AC input voltage thus the designer should try correcting the power factor. A SMPS with a DC input does not require this stage. A SMPS designed for AC input can often be run from a DC supply, as the DC passes through the rectifier stage unchanged. D.C. to D.C. converters and D.C. to A.C. Converters belong to the category of Switched Mode Power Supplies (SMPS).

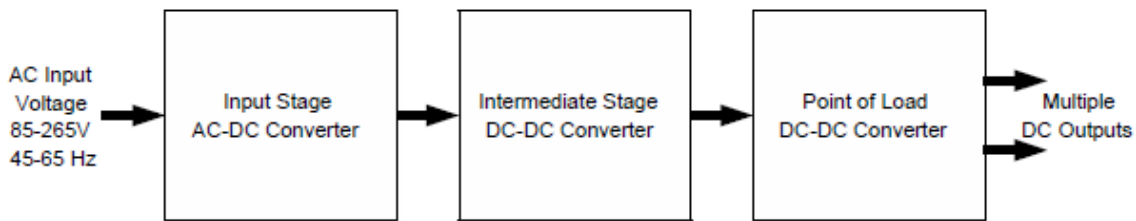

APPLICATIONS:

Switched-mode PSUs in domestic products such as personal computers often have universal inputs, meaning that they can accept power from most Mains supplies throughout the world, with rated frequencies from 50Hz to 60Hz and voltages from 100V to 240V (although a manual voltage "range" switch may be required). In practice they will operate from a much wider frequency range and often from a DC.

Circuit Diagram:

How an SMPS works?

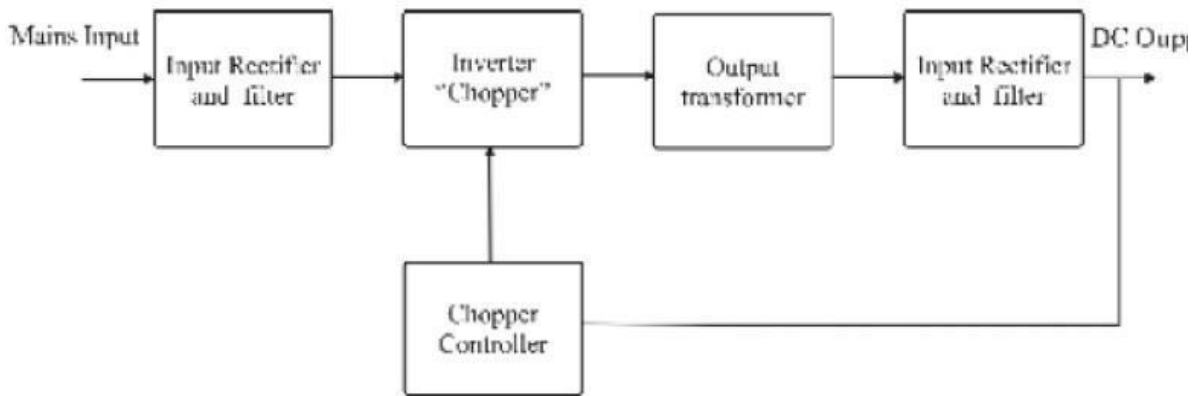

The energy flow in a power supply is controlled by power semiconductors, which can operate in different modes. In legacy systems they worked in linear mode and excessive power dissipated in a series transistor. When a semiconductor operates in switching mode, it can control energy flow with low losses: when a switch is "on", it has low voltage drop and will pass any current imposed on it; when it is "off", it blocks the flow of current. As the result, in such an electronic device the

power dissipation which is the product of voltage and current, can be relatively low in both states. That's why switch mode PSUs offer greater efficiency compared with linear ones. Such units are also smaller in size and lighter in weight due to the reduced size of passive components and lower heat generation. The industry trend toward miniaturization, advancements in semiconductor technology, as well as various energy efficiency regulations have made "switcher" the dominant type of PSU across practically the full spectrum of applications. Most PSU manufactured today for AC input applications also include a PFC front end.

4.4.3 HDD (Hard disk drive) System Interfaces

- Hard Drives 2 Types: SCSI and IDE
- The primary interface used to connect a HDD to a PC is typically called IDE (Integrated Drive Electronics). IDE refers to the fact that the interface electronics or controller is built into the drive and not a separate board.
- Technically the correct name for the interface is ATA, many persist in using the IDE designation today.
- The primary purpose of the hard disk controller, or interface, is to transmit and receive data to and from the drive.
- ATA is a 16 bit parallel interface, meaning that 16 bits are transmitted simultaneously down the interface.
- ATA is used to connect not only hard disks, but also CD and DVD drives, high-capacity Super Disk floppy drives and tape drives.
- SCSI (Small Computer System Interface) is a general-purpose interface used for connecting many types of devices to a PC.
- SCSI is also very flexible. It is not only a disk interface, but is also a system-level interface that allows many types of devices to be connected including scanners and printers.

IDE drives- originally developed as alternative to more expensive SCSI drives. Modern versions called EIDE drives. Support up to 4 multi gigabyte drives. If you want more devices, use SCSI or USB Low-level formatted at the factory

Low Level Formatting

- Low level format scans disk for defects and sets aside sectors with defects so they are not used for data.
- IDE drives should *never* be low level formatted by a user or technician. Only high level format necessary.

Installing IDE/EIDE drives

- IDE supports TWO drives in a system
 - one master (boot disk) and one slave
 - set master and slave using jumpers
- EIDE supports FOUR drives per system
 - 2 drives on each of 2 cables
 - only one master, all others are slaves
- IDE and EIDE drives both use 40-pin ribbon cable aligned to pin 1

SCSI

- Pronounced Scuzzy
- Small Computer Systems Interface
- For wide range of peripheral devices, including hard disks, tape drives, optical drives, CD-ROMs and disk arrays.
- 8 devices can connect to a daisy chain
- This chain must be terminated at both ends
- Each device on chain is assigned unique device ID number that is determined by jumpers or DIP switches

Installing and configuring SCSI

- SCSI bus supports 8 devices
- There are eight SCSI IDs numbered 0 through 7
- ID 7 is always reserved for the SCSI host adapter
- SCSI hard disk, if used as a boot drive, is assigned SCSI ID 0
- If you have both IDE and SCSI hard drive, IDE drive should be boot drive

Types of SCSIs

- SCSI 1- 5 MB transfer rate, Centronics 50 pin or DB 25, has 8 bit bus
- SCSI 2 -also SCSI Fast Wide, includes 16 bit bus , called Wide SCSI, and twice as fast transfer rate
- SCSI 3- Includes Ultra SCSI, Wide Ultra SCSI, and Ultra 2 SCSI, 16 bit bus with up to 80 MBps transfer rate

RAID

- Redundant Array of Independent Disks
- Category of disk drives that employs 2 or more drives in combination for fault tolerance (error recovery)
- 10 levels of RAID
- 3 on test will be: RAID 0, RAID 3, RAID 5
- RAID 0- Striped disk without parity
- RAID 3- Parallel transfer with parity
- RAID 5- Data striping with parity

Data is Organized on Disk

- Tracks-
 - circular areas of the disk
 - Length of a track one circumference of disk
 - Over 1000 on a hard disk
 - Data first written to outer most track
- Sectors-
 - Divides tracks sections
 - On a floppy 9 sectors exits
- Cylinders-
 - Logical groupings of the the same track on each disk surface in a disk unit
- Clusters-
 - Groups of sectors used by operating system
 - 64 sectors in one cluster

Figure 6-14
HOW A HARD DISK WORKS

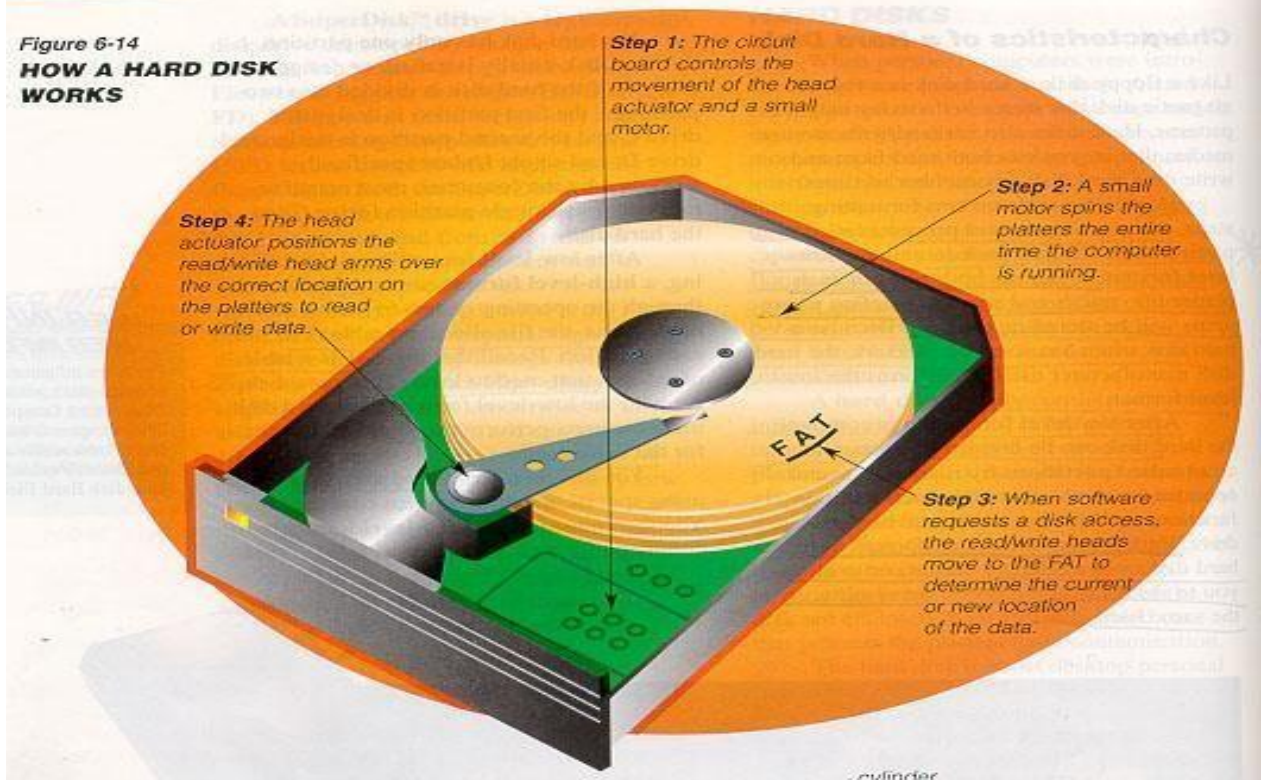

Tracks and sectors

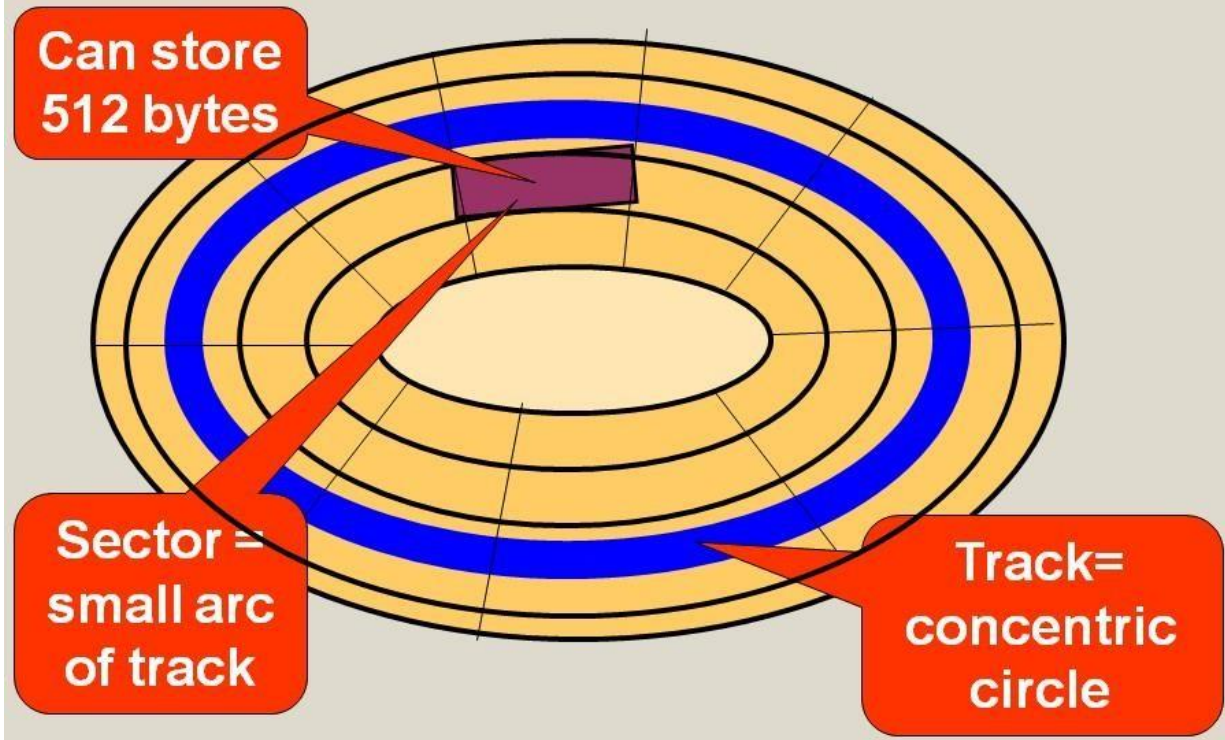

Interleaving

- Allows the read/write head to use the rotation of the disk to its advantage
- One sector is written to and the disk skips to several sectors down

Formatting

- Low level formatting done at factory
 - Builds the File Allocation Table (FAT)
 - Physically scans the disk media for defects
- Remember FAT is always located at Track 0
- High level formatting is automatically done during installation of operating system

Operating System File Systems

- DOS uses FAT
- Windows 3.x uses Virtual FAT
- Win 95 uses VFAT and FAT32
- Win NT uses NTFS

Partitioning

- FDISK command is used
- Divides hard drive into logical subdivisions which are seen by the operating system as separate logical hard disks.
- Hard drives divided into primary and extended partitions. The primary partition boots the system. Can have up to 4 primary partitions
- Extended can be divided up to 23 times on disk.
- Partitioning disks improves disk efficiency through reduced cluster size.
- In DOS, Win 3x and early versions of Win 95 a hard disk over 2 GB must be divided into smaller partitions
- Now Win XP and Win 7 can create a primary partition of up to 30 GB
- Following partition, the first sector on cylinder 0 reserved for master boot record

Disk compression

- Reduce amount of space taken up by files by substituting codes for repeating patterns of data
- To access data on compressed disk, must load disk compression utility into RAM first
- This disk compression utility works between OS and disk controller to intercept requests and compress or decompress files- the result is slower disk access

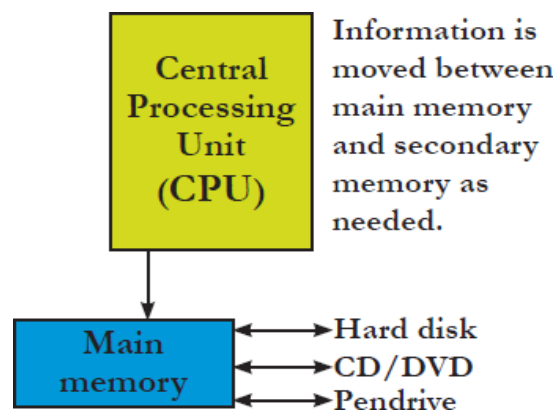

The hard disk drive (HDD) is the data center of the computer. Operating system, software, content (created and save by user) are stored here until explicate deleted. Information is moved

between main memory and secondary memory as and when needed. On power off a computer, data on hard disk and other secondary storage device is not erased.

AT Attachment, is an interface standard for the connection of storage devices such as hard disk drives, floppy disk drives, and optical disc drives in computers. The standard is maintained by the X3/INCITS committee. It uses the underlying AT Attachment (ATA) and AT Attachment Packet Interface (ATAPI) standards. The Parallel ATA standard is the result of a long history of incremental technical development, which began with the original AT Attachment interface, developed for use in early PC AT equipment. The ATA interface itself evolved in several stages from Western Digital's original Integrated Drive Electronics (IDE) interface. As a result, many near-synonyms for ATA/ATAPI and its previous incarnations are still in common informal use, in particular Extended IDE (EIDE) and Ultra ATA (UATA). After the introduction of Serial ATA (SATA) in 2003, the original ATA was renamed to Parallel ATA, or PATA for short. Parallel ATA cables have a maximum allowable length of only 18 in (457 mm). Because of this limit, the technology normally appears as an internal computer storage interface. For many years, ATA provided the most common and the least expensive interface for this application. It has largely been replaced by SATA in newer systems.

Hard disk drives are accessed over one of a number of bus types, including parallel ATA (PATA, also called IDE or EIDE; described before the introduction of SATA as ATA), Serial ATA (SATA), SCSI, Serial Attached SCSI (SAS), and Fibre Channel. Bridge circuitry is sometimes used to connect hard disk drives to buses with which they cannot communicate natively, such as IEEE 1394, USB, SCSI and Thunderbolt. Disk drive interfaces have evolved from simple interfaces requiring complex controllers to attach to a computer into high level interfaces that present a consistent interface to a computer system regardless of the internal technology of the hard disk drive. The following table lists some common HDD interfaces in chronological order:

Acronym or abbreviation	Meaning	Description
SMD	Storage Module Device	<i>Bit serial data interface</i> introduced by CDC Standard interface for many mini-computers in the 1970s and 1980s.
SASI	Shugart Associates System Interface	<i>Word serial interface</i> introduced by Shugart Associates circa 1978; Evolved by ANSI into SCSI (SASI is a compatible subset of the first version of SCSI).
ST-506 ST-412 ST-412RLL		<i>Bit serial data interfaces</i> introduced by Seagate Technology beginning 1980. Standard interfaces for most small HDDs in the 1980s and early 1990s.
SCSI	Small Computer System Interface	<i>Word serial interface</i> sponsored by ANSI and introduced in mid 1980s; Standard interfaces for most enterprise HDDs in this century; superseded by SAS
ESDI	Enhanced Small Disk Interface	<i>Bit serial data interface</i> sponsored by ANSI and first introduced by Maxtor in late 1980s. A higher data rate follow on to the ST-506 family into the mid-1990s, superseded by SCSI
(P)ATA	(Parallel) AT Attachment	<i>Word serial interface</i> introduced in late 1980s by Conner Peripherals and subsequently sponsored by ANSI, Successor to ST-412/506/ESDI. Standard HDD interface on other than enterprise HDDs into this century; superseded by SATA
SATA	Serial ATA	<i>Bit serial interface</i> successor to PATA sponsored by ANSI and introduced in 2003. Most common interface for all but enterprise HDDs.
SAS	Serial Attached SCSI	<i>Bit serial interface</i> successor to SCSI sponsored by ANSI and introduced in 2004. Most common interface for enterprise HDDs.

HDDs are used in many different places for many different purposes. Different interfaces have therefore been developed to meet this diversity. The AT Attachment (ATA) interface was developed for the internal HDDs of desktop PCs, while Small Computer System Interface (SCSI) was developed for servers and large-scale storage systems. Now, these parallel interfaces are being replaced to meet the demands for higher speeds. SCSI is being replaced with FC and SAS,

while AT A is being replaced with SATA. Moreover, because the uses of HDDs are also expanding, interfaces to meet these new uses are also being developed. The serial interfaces of the main HDD of each market segment are shown in parentheses.

- Enterprise (FC)
- Server (SAS)
- Desktop (SATA)
- Mobile (SATA)
- Consumer (stationary) (SATA)
- Consumer (mobile) (CE-ATA)

Hard Drive Technologies and Interface Standards

- A hard disk drive (HDD) comes in two sizes: 3.5" for desktop computers and 2.5" for laptops.
- A hard drive can be a magnetic drive, a solid state drive, or a hybrid drive. A solid state drive contains flash memory and is more expensive, faster, more reliable, and uses less power than a magnetic drive.
- Most hard drives use the ATA interface standards. The two main categories of ATA are parallel ATA and serial ATA. Serial ATA is easier to configure and better performing than PATA. External SATA ports are called eSATA ports.
- S.M.A.R.T. is a self-monitoring technology whereby the BIOS monitors the health of the hard drive and warns of an impending failure.
- ATAPI standards are used by optical drives and other drives that use the ATA interface on a motherboard or controller card.
- Several PATA standards are Fast ATA, Ultra ATA, Ultra ATA/66, Ultra ATA/100, and Ultra ATA/133.
- Three SATA standards provide data transfer rates of 1.5 Gb/sec (using SATA I), 3.0 Gb/sec (using SATA II), and 6.0 Gb/sec (using SATA III).
- The SCSI interface standards include narrow and wide SCSI, and can use a variety of cables and connectors. Three connectors are a 50-pin, 68-pin, and 25-pin connector.
- A SCSI chain can contain up to 16 devices including the host adapter. Each device is identified by a SCSI ID, a number from 0 to 15.

Select and Install Hard Drives

- When selecting a hard drive, consider the storage capacity, technology (solid state or magnetic), spindle speed, interface standard, and buffer size (for hybrid drives).
- SATA drives require no configuration and are installed using a power cord and a single SATA data cable.
- PATA drives require you to set a jumper to determine if the drive will be the single drive, master, or slave on a single cable. The PATA cable can accommodate two drives. A PATA motherboard has one or two PATA connectors for up to four PATA drives in the system.
- RAID technology uses an array of hard drives to provide fault tolerance and/or improvement in performance. Choices for RAID are RAID 0 (striping using two drives), RAID 1 (mirroring using two drives), RAID 5 (parity checking using three drives), and RAID 10 (striping and mirroring combined using four drives).
- Hardware RAID is implemented using the motherboard BIOS or a RAID controller card.

- Software RAID is implemented in Windows. Best practice is to use hardware RAID rather than software RAID.

Differences between SATA and PATA HDD

- The PATA standard is not much in use, because sending data at rates faster than 133 Bps down a parallel ribbon cable has problems associated with it like signal timing, electromagnetic interference (EMI), and other integrity problems. Hence to the problems SATA is preferred.
- The PATA drives cannot be plugged into a SATA host adapters and vice versa.
- The SATA uses much thinner cables with only 7 pins that are easier to plug in.
- Configuration of SATA is also simpler because the jumper settings for master/slave are no longer necessary.
- SATA is a backward-compatible replacement for PATA physical storage interface.
- Utilities that work on PATA will also work on SATA. SATA supports all existing ATA and ATAPI devices, including CD-ROM and CD-RW drives, DVD drives, tape devices, Super-Disk drives and any other storage devices currently supported by PATA.
- Maximum SATA cable length is 1 meter (39.37") which is considerably longer than the 18" maximum for PATA.

4.4.4 Partitioning and formatting HDD

- *Disks.*
 - Used for permanently storing data and programs.
 - Makes it possible to distribute data from one computer to another.
- *Initializing/formatting disk is process of preparing disk so it is compatible with OS.*
 - OS sets up guidelines for reading from/writing to a disk.
 - System utility command (FORMAT.COM) used to prepare a disk for use.
- *All disks, including hard disk, must be formatted.*
 - Purchase new hard disk – must be formatted.
- Hard disks are typically formatted once, when they are new.
 - **Low-level format-** organizes both sides of each platter into tracks and sectors to define where items will be stored on the disk.
 - **Partitioning:** divide hard disk into separate areas called partitions; each partition functions as if it were a separate hard disk drive.
 - **High-level format** defines the file allocation table (FAT) for each partition, which is a table of information used to locate files on the disk.

PARTITIONING AND FORMATTING DISKS

- Disk must be prepared prior to use.
- Hard disk - special process.
- Divided into logical divisions (partitioned).
- Then formatted with file system.
- Partition terms.
- Primary Partition = section of a hard disk.
- Hard disk limited to four primary partitions per physical disk.

- Partition table.
- Located in first physical sector.
- Tell where each partition begins/ends.
- Identifies
- Type of file system for each partition.
- If partition is bootable.
- Volume
- Each partition on drive called a Volume.
- Has own volume label.
- Active Partition.
- Can boot only from active partition.
- Hard disk limited to four primary partitions per physical disk.
- Extended partition.
- Only one primary partition can be an extended partition.
- Can contain logical drives (volumes).
- Dual booting system (system with 2 OSs)
- Create partition for each OS.
- Only one OS active at a time.
- Boot computer from partition where OS is located.
- Each OS formats disks in own way.
- Depending on OS used and file system selected may be able to recognize other drive but no read files on it.
- Precautions in running multiple OS
- W98, WXP and W7, in multiple-boot configuration – compatible.
- Order of installation important.
- Specific information to install multiple OS beyond scope of book.
- File system - organizational scheme of OS.
- OS prepares disk to be read from and written to them.
- OS is what makes one computer compatible with another.
- Process of preparing disk - formatting or initializing disk.
- Focusing on Windows-based formatting.
- WXP supports four file systems.
- NTFS.
- Three FAT file systems (FAT12, FAT16, and FAT32).
- FAT12 – used on floppy disks.
- In reality, choice is either FAT or NTFS.
- WXP supports two types of file systems on CD-ROM and DVD.
- CDFS & UDF.
- All disks must be formatted.
- Hard disk
 - Usually partitioned and formatted.
 - Typically formatted only one time.
- Floppy disks for Wintel computer are also preformatted.
- Two types of disk storage configuration.

- Basic disks.
- Physical disk.
- WXP initializes all disks as basic.
- Dynamic disks.
- Physical disks upgraded/managed by Disk Management utility.
- Do not use partitions/logical drives.
- Only computers running W2K and above can use dynamic disks.

THE STRUCTURE OF A DISK

- Two parts to formatting.
- Low-level (physical) formatting.
- High-level (logical) formatting.
- Low-level (physical) formatting.
- Creates/sequentially numbers tracks/sectors.
- Done to identify each track and sector.
- Number of tracks/sectors varies depending on type of disk.
- High-level (logical) formatting.
- Determines how OS uses disk.
- Builds structure (file system) to keep track of location of files. Done so files can be stored/retrieved

Hard disks.

- Need only high-level formatting.
- Low-level is done at the factory.
- FORMAT command.
- Floppy disk – does high and low-level formatting.
- Hard disk -only high –level formatting done.
- OS monitors status of all disk data sectors.
- Checks sector for damage, or if sector is empty/available for data storage.
- Not efficient to check each sector.
- Groups sectors into clusters (allocation units).
- OS writes data to unread clusters.
- Smallest unit OS works with is a cluster.
- WXP tracks location in file system you have chosen.
- FAT (file allocation table).
- NTFS (New Technology File System).
- Floppy disks only use FAT.
- Cluster space can only be claimed by data allocated to one file.
- Any other file cannot claim space.
- Cluster overhang is wasted space on disk.
- Any other file cannot claim space.
- Cluster overhang is wasted space on disk.

THE MASTER BOOT RECORD AND THE BOOT SECTOR

- Master boot record first part of any hard disk.
- Finds hard disk.
- Launches necessary codes to load drivers located on boot record.
- Boot sector.
- First sector on every logical drive.
- Contains table of drive's characteristics.
- # of tracks/bytes per sector/sectors per track
- Version of OS used to format disk.
- Root directory/volume serial number etc.
- Contains bootstrap loader program.
- Used by W2K to identify type of disk.
- Even if disk not system disk, still has boot sector.
- Error messages if booting from non-system disk.

FAT16, VFAT, AND FAT32

- Using FAT to format disk creates:
 - Boot record.
 - File Allocation Table (two copies).
 - Root Directory.
 - Rest of disk – Files area (data sectors).
 - FAT.
 - Map of disk's data clusters.
 - Entries correspond to every disk cluster.
 - Number of clusters varies from one disk type to another.
 - Cluster size determined by partition size.
 - FAT essential in managing data.
 - FAT number indicates status of cluster.
 - 0 - empty cluster (available).
 - Other specific #'s - cluster reserved or bad.
 - All other #'s - cluster in use.
 - Following trail of data file.
 - FAT # - pointer to next cluster that holds data for that file.
 - FAT #s link clusters belonging to same file.
 - Special entry indicates where file ends.
 - Work in conjunction with root directory table.
- VFAT (virtual file allocation table).
- Special FAT version introduced in W95.
- Allowed backward compatibility and accommodated long file names.
- Variation of original 16-bit FAT.
- Virtual 32-bit FAT - not a real 32-bit FAT.
- W2K and WXP - 32-bit FAT – primary file system.
- Contains maximum of 65,536 clusters on hard drive (2.1GB).
- FAT32 introduced in W95 OSR2.
- Enhanced in W98.

- Overcome limitations of VFAT.
- Based on 32-bit file allocation table entries.
- Will support larger hard drives up to 2 terabytes or 1,000 billion bytes.
- Uses smaller clusters than FAT file system.
- For drives over 512MB.
- Does not apply to floppy drives.
- FAT32 provides further enhancements.
- Moveable root directory.
- Can use backup copy of file allocation table.
- Has internal backup copy of some critical FAT data structure.
- Imposes restrictions on # (over 64000) of entries in root directory table.
- Allows root directory table to be located anywhere on hard drive.
- Advantages/disadvantages of FAT and FAT32 depend on file size and type.
- Smaller clusters.
- More clusters on partition.
- Store more data.
- FAT is larger.
 - Takes longer to locate information to access file.
- Larger clusters.
- Table smaller and takes less time to locate information to access file.
- Increases wasted disk space by cluster overhang.
- FAT32 best if many small files.
- FAT best if mostly large files
- Restrictions.
- FAT32 – only on drives larger than 512MB.
- FAT32 not recognized by DOS W3.1, WNT, and original version of W95.
- W2K and WXP recognize FAT32.
- Floppy disks.
- Always FAT.
- Can be read by any FAT OS.

THE ROOT DIRECTORY

- Table that records information about each file on disk.
- Information displayed (My Computer/Explorer) comes from root directory table.
- Changes made in root directory table make WXP compatible with older W and DOS programs.
- DOS only recognizes 8.3 file names.
- W95/98/2K allow long file name and 8.3 name limitations.
- DOS/W2K/WXP stores information in root directory table for every file on disk.
- Unused area in table used by WXP to handle long file names.
 - . Combination of attributes signal entry is first of series of directory entries.
- Allows series of directory entries to be chained together so long file names can be used.
- WXP maintains compatibility
- Assigns every file - long & short file name (follows 8.3 rule).
- Starting cluster number
- Critical entry in root directory

- Indicates which cluster holds first portion of a file.
- Root directory tells WXP what is on the disk.
- FAT tells WXP where data is on the disk.

THE FAT AND THE ROOT DIRECTORY

- Root Directory.
- Tells you what is on the disk.
- FAT
- Points to where to start finding information about file.
- Acts like a chart – tells you where to go.
- EOF (End-of-file) marker
- Indicates no more data in file.

THE DATA PORTION OR THE FILES AREA

- The Data Portion or the Files Area
- Rest of the disk used for storing files.
- WXP - all files/programs/data are chains of bytes laid out in a sequence.
- Space allocated to files on as-needed basis.
- W2K writes to first cluster available.
- Writes in contiguous clusters when possible
- If necessary uses noncontiguous space.

NTFS

- NTFS used if user wants disk security, performance, and efficiency.
- Advantages of NTFS.
- Secure file system – can assign permission to each file/folder on disk.
- More efficient storage of data on large hard disks.
- Faster access to files/folders.
- IF disk failure - better data recovery.
- Restore disk based on log file.
- Can compress files – more data can be stored on disk.
- Can assign disk quotas – set limits on how much disk space a user may have.
- Encryption of files for better security.

CLUSTERS AND NTFS

- NTFS.
 - Uses FAT cluster scheme for allocating data.
 - Has fewer overheads.
 - Reducing operating overhead can allocate more computer resources to work you want done.
- Structure of NTFS volume looks similar to FAT – but there are differences.

MASTER FILE TABLE (MFT)

- NTFS uses Master File Table (MFT) instead of FAT.
- MFT.
- Database of all files on system.
- Tracks all files/directories in volume
- Dynamic – changes size when necessary.
- First 16 records called Metadata files.

- Contain information about volume.
- Considered overhead for maintaining the file system.
- MFT has entry for MFT itself.
- Other files log files, mark bad clusters, root directory.
- After volume info, each record in MFT corresponds to one file or file in file system.
- Record for file/folder contains attributes.
- MFT additions or differences from FAT.
- Major attribute – adds security descriptor
- Who has what access to what files.
- NTFS – secure file system
- Can assign permission for every file/folder on system.
- Data in file considered to be attribute in file.
- Data small – file fit in MFT
- Fast access
- Eliminates file fragmentation.
- Most files too large to fit MFT.
- NTFS stores it in new separate set of clusters called run or extent.
- Any attribute stored in MFT considered to be a resident attribute.
- Any attribute forced out is nonresident attribute.
- Folders treated as files in NTFS.
- Folder small –
 - Index to files in folder kept in NTFS –
 - Called Index Root Attribute.
- Folder large – NTFS creates a new extent with nonresident attributed –an Index Buffer.
- Contains a data structure called a B-tree.
- B-tree stores indexes to data in a sorted order.

DECIDING ON A FILE SYSTEM

- Can choose file system when installing WXP
- Can convert FAT to FAT32 or NTFS.
 - One-way conversions.
 - Cannot convert FAT32/NTFS to FAT.

CLARIFYING PROCEDURES

- System utility files subdirectory.
- Will be at command prompt screen.
- Need to be in subdirectory that has system utility files.
 - Blank or new disk.
 - Any special lab procedures?

ACTIVITY—FORMATTING A FLOPPY DISK

- Warning! Never format a disk with information you wish to keep.
- Activity steps.
- Open a Command Prompt window
- No disk in Drive A
- Key in following:
- CD \WINNT\SYSTEM32

- DIR FORMAT.COM
- FORMAT A:
- Prepare and affix label to blank disk. Name it —DATA disk and insert it into Drive A.
- Press <Enter>/<Enter>/<Enter>/N/<Enter>
- Press <Enter>/N/<Enter>
- Key in: CD \
- Activity completed.

FORMATTING A DISK WITH A VOLUME LABEL

- Can use parameters other than the disk drive letter with the FORMAT command.
- Syntax for FORMAT commands (with parameters).
 - Explain function of each parameter.
 - Parameters work but have been superseded.
 - Beginning with MS-DOS version 3.3 volume or drive letter mandatory.
- Important parameters to remember are:
 - FORMAT volume [/V: label] [/Q]
 - /Q performs quick format –
 - Used only on previously formatted disk.
 - Deletes entries from FAT and root directory but leaves files untouched.
 - /V – used to place volume label on disk.
 - /F: size – format floppy disk that does not match capacity of floppy disk drive.
 - Discuss function of /F: size.
- Volume label.
 - Electronic name.
 - Like labeling file drawer.
 - Formatting disk in recent versions of OS automatically asks for volume label even if /V not included.
 - If parameter /V (fixed) included can provide label itself (variable) and eliminate step.

ACTIVITY—USING THE /V OPTION

- C:\> is displayed and a formatted disk in A:
- Activity steps.
 - Key in:
CD \WINNT\SYSTEM32
FORMAT A: /V: SAMPLEDATA
 - Press <Enter>
 - Key in: N/DIR A: then VOL then VOL A:
- Activity completed.

THE LABEL COMMAND

- C:\WINNT\SYSTEM32> displayed.
Disk just formatted is in Drive A.
- Activity steps.
 - Key in: LABEL A:
 - Press <Enter>.
 - Key in: Y then VOL A:
 - Key in: LABEL A:SAMPLE DATA

- Key in: VOL A:
- Activity completed.

ACTIVITY—USING THE LABEL COMMAND

- C:\WINNT\SYSTEM32> displayed.
Disk just formatted is in Drive A.
- Activity steps.
 - Key in: LABEL A:
 - Press <Enter>.
 - Key in: Y then VOL A:
 - Key in: LABEL A:SAMPLE DATA
 - Key in: VOL A:
- Activity completed.

FORMATTING A DISK USING THE /Q PARAMETER

- Only works on previously formatted disk.
- Works like usual FORMAT command,
 - Skips low-level formatting.
- Clears FAT and root directory.
- Does not check for bad sectors on the disk.
- Fast way to erase a disk.

4.4.5 Different Standards of Expansion Units

Computer components send and receive data between different devices by the use of a **bus**. The design and type of the bus therefore has a crucial effect on how well a computer system will operate. If you have a high speed drive and a fast CPU, but a slow bus, data will be held up and the individual components will not operate at the speed they are capable. Manufacturers have developed standard methods for connecting different devices and for the design of bus technology. This has benefited everyone by allowing the purchase of devices from different manufactures and not having to worry that the devices will talk to each other.

Bits	Bus Type	Description
16 Bit	ISA	Industry Standard Architecture
	EISA	Extended Industry Standard
32 Bit	Micro-Channel	IBM's proprietary architecture
	VESA (VL-Bus)	Video Electronics Standards Association
64 Bit	PCI	Peripheral Component Interconnect

Property	Bus Type			
	ISA	EISA	VESA	PCI
MHz	8.3	8.3	33	33
Bits	16	32	32	32 or 64
Mbps	8.3	33	160	132 or 264
Voltage	5	5	5	3.3 or 5

- **MHz** – Think of 33 MHz as miles per hour or speed.
- **Mbps** (Mega bytes processed per second, transfer rate) translates how many cars could travel the highway within a time period of one second. A higher Mbps value represents a faster device.

- **Bit Specification**, are the number of lanes on the highway. 16 bit = 16 lanes, 32 = 32 lanes etc. the more lanes, the more traffic that can be accommodated.
- **Voltage references**, like 5V or 3.3V, is similar to miles per gallon with the exception that the lower the voltage, the better the gas mileage.

Comparison between ISA, EISA and VESA bus

	ISA	EISA	VESA
Number of bits	8/16 bit	32 bit	32 bit
Memory addressing	8 bit addressing or 16 bit addressing for DMA microprocessor	32 bit addressing for DMA microprocessor and bus master devices.	32 bit memory addressing
Design	Simple	Simple	Simple
Bus mastering arbitration		Enhanced DMA arbitration and transfer rates	It does not support bus mastering and no good arbitration.
Data transfer rate	8.33 MB/s for bus masters and DMA devices	33 MB/s for bus masters and DMA devices.	132 MB/s. it is 16 times faster than ISA bus
Use	8086 processor	80386 and 80486 processors.	80486 processors for videocards.

Comparison between VESA and PCI bus

	VESA	PCI
Abbreviation	Video Electronics Standard Association (VESA)	Peripheral Component Interconnect (PCI)
Year of Introduction	1992 by VESA	1992 by Intel
Use	Video cards	Graphics display adapters, network interface controllers, disk controllers.
Performance	Good	Highest as compared to ISA, MCA, ISA and VESA buses.
Bits	32 bits local bus	32 bit or 64 bit local bus.
Processor	80486 processor	High speed Pentium processors and advanced versions.
Bandwidth	132 MB/s	132 MB/s for 32 bit PCI bus and 264 MB/s for 64 bit PCI bus.
Plug and play	Not supported	It supports plug and play mechanism.
Bus mastering	Not supported	It provides bus mastering and

		provides arbitration.
Addressing	32 bit addressing	64 bit addressing
Expansion cards	Video few cards can be used.	It supports many expansion cards in comparison to VL bus.

4.5 The Post Sequence (Power-On Self-Test)

Booting process runs a Power-On Self Test (*POST*) to check the devices that the computer will rely on, are functioning.

Checks that the basic components are functioning correctly

- Motherboard
- Power supply
- Memory
- Video
- Keyboard

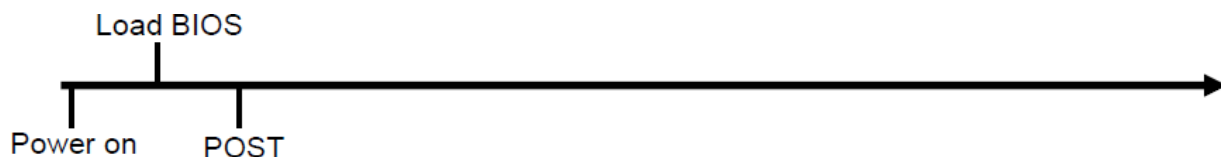

- . Problems are indicated through the system speaker
- . Consult BIOS/system manual for the meaning of the beep sequences
- . Example, repeated long beeps indicate memory problems.

4.6 Keyboard Interface

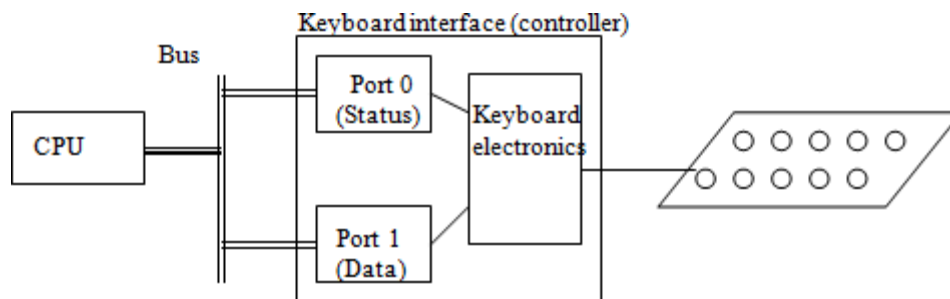

Figure 3. Keyboard controller

Port: an addressable register

- *input only ports:* CPU only reads from it
- *output only ports:* CPU only writes to it
- *ports for both input and output*

Every port has a number. A port can be referred to in an assembly language program by its number, such as: IN 1

Status port: checked by the CPU to see if a key has been pressed and data is ready to be sent to CPU

Data port: when a key is pressed, its ASCII code is found in the data port

Polling: CPU continually examines the status port until a key is pressed (Programmed I/O)

Ex: Reading a character from keyboard

```
KEYIN:    IN    0    ; read status port into A
          ANA   A    ; test A (10H – key is pressed, 00H – otherwise)
          JZ    KEYIN ; jump if 00H
          IN    1    ; take data into A
          RET
```

The Keyboard Hardware Interface

The PC interfaces to the keyboard using two separate microcontroller chips. These chips provide user programming registers and a very flexible command set. If you want to program the keyboard beyond simply reading the keystrokes produced by the keyboard (i.e., manipulate the LEDs on the keyboard), you will need to become familiar with the registers and command sets of these microcontrollers.

The Keyboard DOS and BIOS Interface

Both DOS and BIOS provide facilities to read a key from the system's type ahead buffer. As usual, BIOS' functions provide the most flexibility in terms of getting at the hardware. Furthermore, the BIOS int 16h routine lets you check shift key status, stuff scan/ASCII codes into the type ahead buffer, adjust the auto repeat rate, and more. Given this flexibility, it is difficult to understand why someone would want to talk directly to the keyboard hardware, especially considering the compatibility problems that seem to plague such projects.

The Keyboard Interrupt Service Routine

Although accessing the keyboard hardware directly is a bad idea for most applications, there is a small class of programs, like keyboard enhancers and pop-up programs, that really do need to access the keyboard hardware directly. These programs must supply an interrupt service routine for the int 9 (keyboard) interrupt.

A keyboard macro program (keyboard enhancer) is a perfect example of a program that might need to talk directly to the keyboard hardware. One problem with such programs is that they need to pass characters along to some underlying application. Given the nature of applications present in the world, this can be a difficult task if you want to be compatible with a large number of PC applications.

4.7 Steps for assembling of a computer

To assemble a computer and boot the system for the first time.; these are some important points to remember: Computer cases come in a variety of sizes and configurations. Many of the computer's components must match the case's form factor.

- The CPU is installed on the motherboard with a heat sink/fan assembly.
- The power supply is installed in the PC.
- RAM is installed in RAM slots found on the motherboard.
- Adapter cards are installed in PCI and PCIe expansion slots found on the motherboard.
- Hard disk drives are installed in 3.5-inch drive bays located inside the case.
- Optical drives are installed in 5.25-inch drive bays that can be accessed from outside the case.
- Floppy drives are installed in 3.5-inch drive bays that can be accessed from outside the case.
- Power supply cables are connected to all drives and the motherboard.
- Internal data cables transfer data to all drives.
- External cables connect peripheral devices to the computer.

- Beep codes signify when hardware malfunctions.
- The BIOS setup program is used to display information about the computer components and allows the user to change system settings.

4.8 Software settings of computer after installation (CMOS-setup)

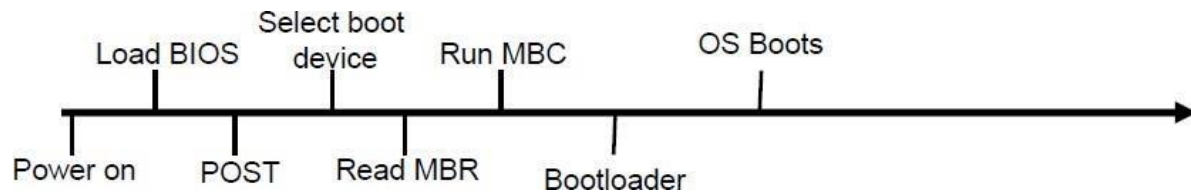

Memory types speed and timing—Adjust the values here to match the memory installed in the system (such as parity, non-parity, SDRAM, EDO, and so on).

Cache adjustments—Some Cyrix CPUs require the user to disable pipelining for proper operation.

Configuration of USB ports—If you upgrade a system to Windows 98 or Windows 2000, you might need to enable the USB ports; systems with older versions of Windows (which didn't support USB) might not have the USB ports enabled. The USB Keyboard Support feature must be enabled if a USB keyboard is installed to allow the keyboard to operate outside of Windows.

Configuration of the AGP slot—Depending on the specific AGP video card installed (if any), you might need to set the size of the memory aperture used to transfer data between the system and the AGP port and select the AGP mode (1x, 2x, and 4x).

Power Management Configuration- Power management works like this: After a user-defined period of inactivity, devices such as the monitor, the hard drive, or even the CPU will go into different low-power modes:

- **Standby mode**—Shuts off the hard drive and blanks monitor screens that use Display Power Management Signaling. Move the mouse or press a key to "wake up" the system.
- **Suspend mode**—Turns off the CPU clock to save even more power. Systems that fully support suspend mode allow you to choose a special shutdown option that "remembers" what programs and files were open, and can bring the system back to that state when the power is restored.

PnP (Plug-and-Play) Configuration Screen

Plug-and-Play (PnP) configuration allows either the operating system or the system BIOS to select hardware settings for PnP-compatible cards when first installed and to change those settings when new cards are installed

Security/Passwords

You can enable two types of passwords on many systems: a power-on password that must be entered to allow any use of the system, and a setup password that must be entered to allow access to the BIOS/CMOS setup. If you don't have all the settings recorded (with screen printouts or by writing them down), this can be dangerous to enable.

Installation or setup is the act of making the system or program ready for execution. Because the process varies for each program and each computer, programs (including operating systems) often come with an installer, a specialized program responsible for doing whatever is needed for their installation. Configuration is an arrangement of functional units according to their nature, number, and chief characteristics. Often, configuration pertains to the choice of

hardware, software, firmware, settings, and documentation. The configuration affects system function and performance.

(A) Install an operating system:

- Windows: Review Microsoft: Installing and Reinstalling Windows. Using virtualization software, install Windows 7 or later in a virtual machine.
- OS X: Review Apple: Installing OS X on an External Volume. Either use virtualization software to install OS X in a virtual machine or follow the instructions to install OS X on an external volume.
- Linux: Review HowToGeek: 10 of the Most Popular Linux Distributions Compared and Linux.com: How to Install and Try Linux the Absolutely Easiest and Safest Way. Select a Linux distribution. An Ubuntu/Mint variant is recommended for workstation use, CentOS is recommended for server use. Using virtualization software, install the Linux distribution in a virtual machine or follow the instructions to try one or more Linux distributions.
- Chromium OS: Review Wikipedia: Chromium OS. Download Neverware: CloudReady Chromium OS. Using virtualization software, install Chromium OS in a virtual machine.

(B) Perform system updates:

- Windows: Review Microsoft: Windows Update. Run Windows Update and install any missing critical updates.
- OS X: Review Apple: Update OS X and App Store Apps on your Mac. Check for software updates and install any missing updates.
- Linux: Review Linux.com Updating Your System. Check for system updates and install any missing updates.
- Chromium OS: Review Google: Update your Chromebook operating system. Check for system updates and install any missing updates.

(C) Add features:

- Windows 7: Review Microsoft: Turn Windows Features On or Off. Open the Windows Features dialog box and examine the various Game options available. If all games are off, select one or more games and turn them on. If all games are on, select at least one game and turn it off. Check the Start menu / All Programs / Games to verify if the feature was added or removed. Then reverse the setting to either install it again or uninstall it to return your system to its original configuration.
- Windows 8: Review Microsoft: Turn Windows Features On or Off. Use the Start Menu Search feature to run Turn Windows Features On or Off. Test enabling a feature by adding the Telnet Client. Then uninstall it to return your system to its original setting. (Games and other applications may be added through the Windows Store.)
- OS X: Review Apple: App Store. Use the App Store to install a game. Then use the Finder and go to the Applications folder. Find the game you installed and move it to the trash to delete it.
- Linux: Review Control-Escape: Installing Software on Linux. Using your system's package manager, install one more games. Confirm the game was installed. Then use the package manager to uninstall the game.

(D) Configure keyboard, mouse, display, sound, etc.

- Windows: Review Microsoft: Working with Control Panel. Use Control Panel applets to configure keyboard, mouse, display, sound, and other settings.
- OS X: Review Apple: Set Your Preferences. Use System Preferences to configure keyboard, mouse, display, sound, and other settings.
- Linux: System settings vary by distribution. Search the Internet for system settings information for your Linux distribution. Use system settings applications to configure keyboard, mouse, display, sound, and other settings.

(E) Create user accounts.

- Windows: Review Microsoft: Create a User Account and Microsoft: Change User Account Types. Create a new administrator account and a new standard user account. Test the accounts and identify differences between the account types. Delete the accounts when you're finished.
- OS X: Review Apple: Set Up Users on Your Mac. Create a new administrator account and a new standard user account. Test the accounts and identify differences between the account types. Delete the accounts when you're finished.
- Linux: User management tools vary by distribution. Search the Internet for information on how to create or add users for your Linux distribution. Create a new administrator account and a new standard user account. Test the accounts and identify differences between the account types. Delete the accounts when you're finished.

(F) Research and compare license and support costs for Windows, OS X, and Linux.

(G) System configuration

The system configuration setting of a client computer comprises of the network setting, domain name, computer name, IP address, and so on. Deployment Solution lets you create system configurations to apply on the client computers after they boot to the production environment from the preboot environment or automation environment. For example, after you boot 50 client computers to the production environment, you might want the computer names to be modified and also join a common domain. This task can be performed through the system configuration that you create and apply on the client computers.

(H) Software

We install a standard set of programs as part of the Computer Setup service. To view a list of installed programs, visit the Standard Mac and Standard Windows pages. We can install any software you are licensed for on request. If you need to purchase additional software, you can order using the ITS Software order form on the ITS Software pages.

5.0 Basic Maintenance of Computer and Trouble Shooting Procedures

5.1 Basic maintenance concepts

Computer maintenance is the practice of keeping computers in a good state of repair. A computer containing accumulated dust and debris may not run properly. Dust and other crud may accumulate as a result of air cooling. Any filters used to mitigate this need regular service and changes. If the cooling system is not filtered then regular computer cleaning may prevent short circuits and overheating. System maintenance is an umbrella term that encompasses various forms of computer maintenance needed to keep a system running. The two main components of system maintenance are preventive and corrective maintenance. Preventive maintenance involves taking measures to help keep the system functioning, whereas corrective maintenance involves the replacement or repair of a system or its components after they have already failed.

(I) Preventive Maintenance

Preventive maintenance is defined as the proactive maintenance of equipment before a fault or failure occurs. Preventive maintenance involves routine tasks to ensure that your system is running optimally and to avoid problems before they arise. This is similar to routine maintenance performed on a car: In the same way you need to periodically check the oil, lights, engine, and other parts of the car in order for it to run smoothly, the same principle applies to preventive maintenance for a computer. There are several preventative measures you can take, including installing Windows updates, scanning for viruses and malware, and running cleaning programs. Anti-virus and anti-malware scans should be run at least once a week. Be sure to run updates for these programs whenever they're released, as new viruses and malware spring up constantly. Keeping your network secure, installing a firewall, and using safe downloading practices can protect your computer and any information on it from being compromised. Power surges and overheating can destroy electronic equipment, so protect your hardware by investing in a surge protector and cleaning your equipment periodically to remove dust. Should any preventative measures fail, it is always a good idea to have a backup for important files: Invest in an external hard drive to save any important files should your computer need replacing.

(II) Corrective Maintenance

Corrective maintenance, commonly referred to as "repair," is the correction of a problem after the computer has already broken down. The goal of this form of maintenance is to restore operability to the system by either correcting the problem or replacing the damaged components. Common corrective measures involve removing viruses and malware, uninstalling harmful programs, reformatting, and running a system restore, among others. Many common computer problems are easily fixed and don't require an IT professional. To perform corrective maintenance, it is important to first diagnose the problem and figure out the root cause. If you are unsure of the cause or how to fix your problem, consulting an IT professional would be the best course of action.

(III) On-line Maintenance

Remote administration refers to any method of controlling a computer from a remote location. Software that allows remote administration is becoming increasingly common and is often used when it is difficult or impractical to be physically near a system in order to use it. A remote location may refer to a computer in the next room or one on the other side of the world. Unlimited remote support during office hours. Users can contact us via email, telephone.

Our support engineers use a remote access service which allows them to connect to the problematic system, and fix it without having to visit your office.

5.2 Type & nature of fault

A -fault| is another word for a problem. A -root cause| fault is a fundamental, underlying problem that may lead to other problems and observable symptoms. (It might not be directly observable). A root cause is also generally associated with procedures for repair. A "fault" or "problem does not have to be the result of a complete failure of a piece of equipment, or even involve specific hardware. For instance, a problem might be defined as non-optimal operation or off-spec product. In a process plant, root causes of non-optimal operation might be hardware failures, but problems might also be caused by poor choice of operating targets, poor feedstock quality, poor controller tuning, partial loss of catalyst activity, buildup of coke, low steam system pressure, sensor calibration errors, or human error. A fault may be considered a binary variable (|OK| vs. -failed|), or there may be a numerical -extent|, such as the amount of a leak or a measure of inefficiency.

A fault in a computer system affects the normal operation of the computer, i.e, the computer malfunctions. The symptoms of malfunction are almost unlimited and vary with the nature of the fault. The types of symptoms we often come across are listed below:

- A program has given wrong results.
- A program is looping continuously
- The CPU has lost control
- There is a junk display on the CRT
- The HDD is not working
- Opening more than one window causes the system software to hang
- Computer intermittently cancels job with any of the following messages:
 - . Spurious Interrupt
 - . Memory parity error
 - . File not found
 - . Divide by zero
 - . Overrun
- A program gives different results at different runs

Nature of faults: solid and intermittent

Computer faults can be broadly classified into 2 types based on frequency of occurrence of the program.

- Permanent or Solid fault: When there is a permanent in a computer misbehaves consistently. Any number of times the program is run, the result or symptoms will be same.
- Intermittent fault: When there is an intermittent fault, the computer's behavior is not consistent. Sometimes it works properly and suddenly it malfunctions. After a certain period of time, it recovers from the fault automatically and again starts functioning properly.

Types of Faults: (Hardware & Software)

A hardware which works now may fail even in the next second. But a software one proven always works. Hence if there is a software fault in a computer, it is because of one the following two reasons:

- The program is not proven. It is a new which is not yet debugged thoroughly.
- The program works only for certain types of data. This is due to the incomplete testing of the software.

Software errors may appear to be hardware errors. A hardware problem is classified as a fault in an actual component or in the configuration of that component.

- Electronic problems
- Mechanical problems
- Environmental problems
- Media problems

Each of these types may cause both solid and intermittent problem. They may cause a similar problem. In practice, it is easier to identify the cause of solid problems. An intermittent mechanical problem may give symptoms that may mislead the engineer to conclude it as electronic problem. The symptoms caused by the media problems make one think that they are either hardware or software problems. Hence an intermittent problem needs a very careful and systematic approach.

Manifest on of Faults

• Fault effects may be permanent or temporary

- Same fault may result in different effects depending on where/when it occurs
- A soft error in the code segment is a permanent error while one in the data segment may be temporary

. Faults may affect different layers differently

- A permanent fault in the logical level may manifest as a temporary fault at the architectural level if the function unit in which it occurs is often unused.

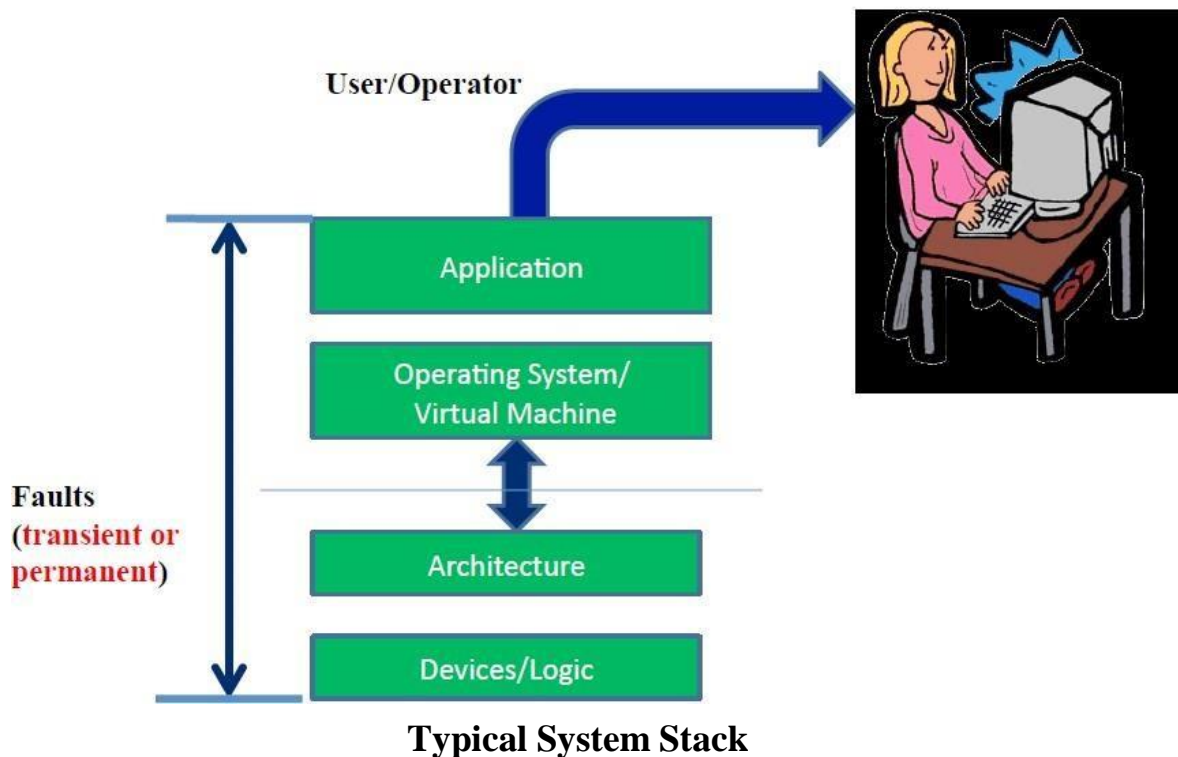

(i) **System Stack: Logical level** – soft error, timing errors etc.



Soft errors

Timing errors

Stuck-at-fault (Permanent)

- Assume that some gate/line gets —stuck
- Can be stuck-at-0 or stuck-at-1
- May not correspond to real physical faults
- Very useful for evaluating test cases in ATPG

Bit-Flip Model (Transient)

- Can be caused by cosmic rays/alpha particles striking flip-flops or logic gates (Soft errors)
- Leads to one or more bits getting -flipped

(ii) **System stack: Architectural level** – Design defects, wearout-related defects

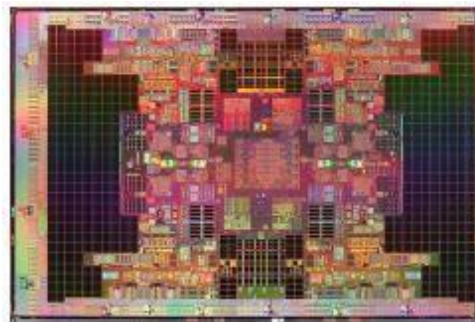

Design Defects

Wearout-related defects

Permanent Errors

- Some functional unit in the processor fails (e.g., an ALU stops working; cache line has a stuck-at-fault).
- Certain instructions are always executed incorrectly due to design errors (e.g., adds always encounter error when value overflows register width).

Transient Errors

- Some units experiences an error for 1 cycle/instruction (e.g., an entry in the ROB has a bit-flip for 1 cycle)
- Cache line has a single bit-flip due to cosmic ray strike

(iii) **System Stack: OS/VM level – kernel error, driver error**



Kernel Error



Driver error

Permanent Error

- An instruction or data item was corrupted by a fault in the disk image of the OS
- Device experiences a permanent failure

Transient Error

- An OS data/code page in memory is corrupted
- A device experiences a transient malfunctioning
- The kernel experiences deadlock/livelock

(iv) **System stack: Application Level – Concurrency bugs and Memory corruption errors**



Concurrency bugs

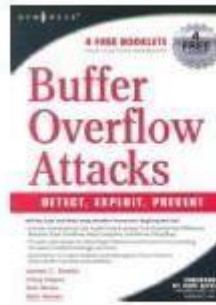

Memory corruption

Permanent Errors

- Programming errors in application logic-mutation of source code or binary file
- Corruption of configuration files/data-bases needed by the application

Transient Errors

- Software memory corruption errors or corruption of memory locations
- Race conditions/Atomicity violations or lock elision

(v) **Operator/User Level**

Permanent Errors

- Errors in configuration files/databases due to user's carelessness or misunderstanding of parameters
- Wrong semantic model of the application

Transient Errors

- User types in incorrect command/GUI action due to carelessness or oversight
- Operator attempts to upgrade hardware or software and upgrades the wrong component/package

5.3 Diagnostic program and tools

A **diagnostic program** is a program written for the express purpose of examining the state, or locating problems with the hardware, or operating system environment that it is running on/in. A diagnostic program is a program written for the express purpose of locating problems with the software, hardware, or any combination thereof in a system, or a network of systems. Preferably, diagnostic programs provide solutions to the user to solve issues.

Examples

- Diagnostics that are run on-demand when a user needs assistance, typically within the primary operating system of the computer (e.g. Windows)
- "Off-line diagnostics" that are run outside the primary operating system, typically to reduce the masking influence of software on hardware issues
- Background diagnostics that monitor the system for failures and marginal events, and provide statistical data for failure prediction, and root cause analysis of actual failure conditions
- Solutions-oriented diagnostics, that diagnose and resolve user-perceived issues with a computer system.
- In some cases hardware components have specific features to assist a diagnostic program to test it. For example, most modern hard drives have commands that provide information about some permanent error conditions. Also, some systems with ECC memory will log memory failures that were automatically corrected.

Methods of Operation

- Black box, which is testing of a mechanism without knowing how it works, and merely focusing on the accuracy of output data based on a known input.
- White box, which uses knowledge of a mechanisms inner functions to direct testing.
- Operation-oriented, a combination of both black and white box, with one or more black-box operations interleaved with one or more white-box operations. This mode of testing is not preferred; however some complex systems do not have the necessary interfaces to perform one or the other type independently.
- Background monitoring of system indicators, for statistical analysis of trends, and for recording abnormal events
- Background diagnostics, that perform testing of system components during idle-time of a system
- Operation-interleaved diagnostics, that incorporate diagnostics into the normal operation of a system component, thus any marginal operating mode is immediately diagnosed

- Solution-based diagnostics, that test for known failure modes by identifying if their known symptoms are detected.

Architectures

- Single-purpose diagnostic, also referred to as "Defined-purpose" diagnostic, such as a program that validates the Windows DirectX configuration
- Multi-purpose diagnostic, a monolithic program that performs multiple tasks that may or may not be suitable for all uses. This would be similar to a hammer that will perform well with nails, less so with screws, and poorly with nuts and bolts.
- Modular diagnostic, which combines sets of single-purpose diagnostics into an environment that is easily tailored for particular requirements.
- Knowledge-Driven diagnostic system (such as a technician or diagnostician) where the knowledge acquired over time is used as a "mental model" of the system's operation and informs the diagnostic system through logical reasoning to one or more possible or likely causes for a situation to exist.

Diagnostic tools

Computer manufactures supply special diagnostic programs. These programs contain test routines to verify the various functions of the computer hardware. Running these programs helps one to decide whether the hardware is faulty or not. In order to verify the presence of intermittent problems, it is necessary to run the diagnostics multiple times. These test programs very often help us to confirm whether a problem in a computer is related to hardware or software. If diagnostic programs run successfully without pointing out any problems, then the chance of a hardware fault is remote. But there are two exceptions to this:

- Intermittent problems may play a hide and seek
- Some problems may be too complex to be detected by simple diagnostic programs. These faults may occur only when several subsystems work simultaneously.

Unless diagnostic programs simulate the above two situations, then faults may not be caught by the diagnostics programs. The Software routines that test hardware components (memory, keyboard, disks, etc.) diagnostics are often stored in ROM chips and activated on startup. Computer errors can occur due to either hardware or software issues and often requires time consuming trial-and-error troubleshooting to diagnose. The diagnostic tools cover the usual culprits such as memory, hard drives, video cards and software, allowing you to pinpoint the source of your computer troubles. In instances where the tools cannot outright repair the errors, the information provided can be key to determining what has to be replaced. Your desktop computer comes with several sophisticated diagnostic programs. Technicians use these tools to find the causes of erratic behavior in the computer, slow operation and other problems. The POST , Check Disk, Task Manager, Windows Defender, Drivers these programs consist of software that is built into hardware drivers and components of the Windows operating system.

5.4 Give Firmware (POST) concepts

Firmware can be mainly referred to as being a fixed, rather small program that controls hardware in a system. Firmware is generally responsible for every basic low-level operation without which a device would be completely non-functional. Usually firmware is stored in Flash, ROMs, PROMs, and EPROMs. In most cases, firmware is not supposed to be changed by the user. The POST checks, identifies, and initializes system devices such as the CPU, RAM, interrupt and DMA controllers and other parts of the chipset, video display card, keyboard, hard disk drive, optical disc drive and other basic hardware. A power-on self-test (POST) is a process performed

by firmware or software routines immediately after a computer or other digital electronic device is powered on. The results of the POST may be displayed on a panel that is part of the device, output to an external device, or stored for future retrieval by a diagnostic tool. Since a self-test might detect that the system's usual human-readable display is non-functional, an indicator lamp or a speaker may be provided to show error codes as a sequence of flashes or beeps. In addition to running tests, the POST process may also set the initial state of the device from firmware. Most computer peripherals are themselves special-purpose computers. Devices such as printers, scanners, cameras and USB flash drives have internally stored firmware; some devices may also permit field upgrading of their firmware.

- Firmware is programming that's written to a hardware device's nonvolatile memory.
- Firmware, which is added at the time of manufacturing, is used to run user programs on the device and can be thought of as the software that allows hardware to run. Hardware makers use embedded firmware to control the functions of various hardware devices and systems, much like a computer's operating system (OS) controls the function of software applications.
- Firmware may be written into read-only memory (ROM), erasable programmable read-only memory (EPROM) or flash memory. Firmware that is embedded in flash memory chips can be updated easier than firmware written to ROM or EPROM, which makes it more adaptable.
- Firmware updates are often issued to fix bugs, roll out new features and improve security.

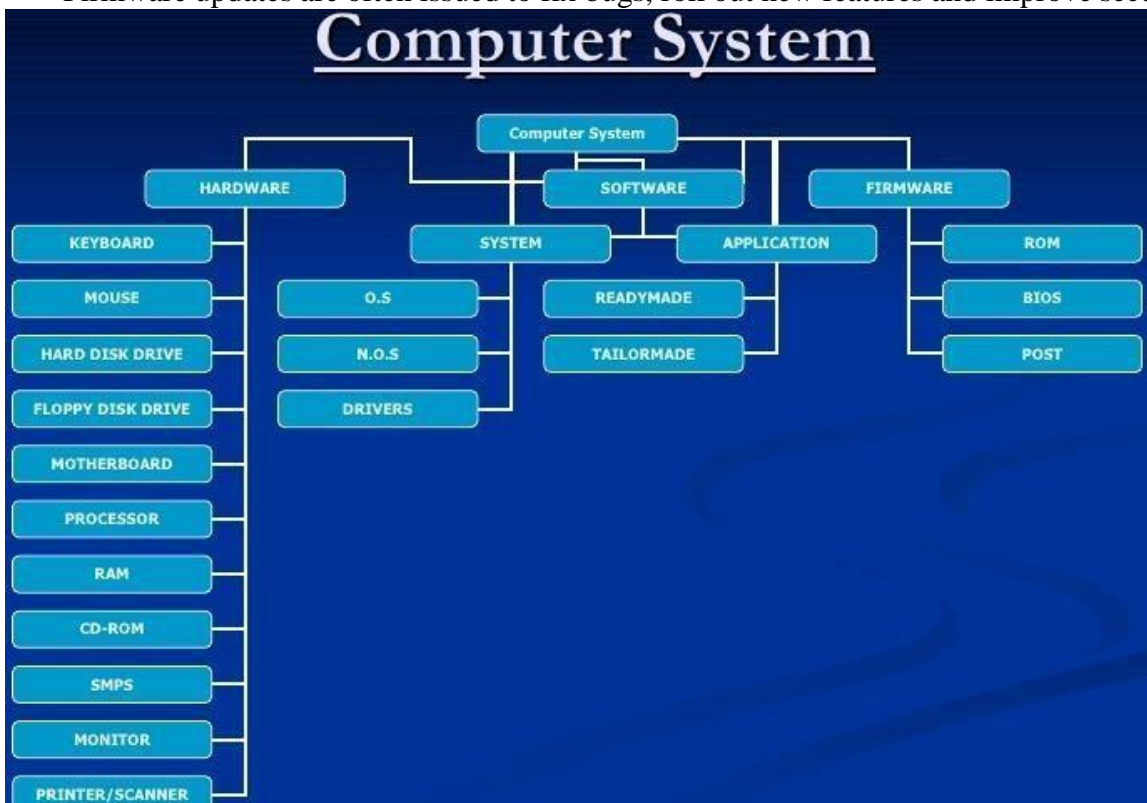

5.5 Fault elimination process

Fault finding is a technique. Some faults can be easily traced out if one proceeds systematically, starting from the symptoms. Some faults show complex symptoms with no clue at all. For such faults there are no defined starting points. In such case, service engineers should try out an appropriate elimination process. The steps of fault elimination procedure are common to any computer. Some of these can be omitted depending on the symptoms.

(I) **Dead System:**

A computer is said to be dead when an absolutely essential signal is absent. It is easy to confirm whether a system is dead or alive. The following are some of the symptoms of a dead computer:

- DC voltage is absent
- clk signal is absent
- ROM output is inactive
- Microprocessor is faulty or dead
- The ac fuse is blown

(II) **Spurious Problems:**

Sometimes the computer malfunctions randomly. Logical and systematic trouble shooting may not yield any clue. In such case the engineers should look for symptoms of spurious problem. Some of the hidden symptoms of spurious problems are –

- DC voltage has excessive ripples
- DC voltage is noisy
- clk signal is not stable
- loose contacts of cables and connectors
- there is noise pick up on the next input or on other bus signals.

(III) **Security Failures:**

In any computer, sometimes there are abnormal symptoms, due to malfunctioning of special hardware meant for error detection. Three types of problems are caused by such security logic:

- When there is no error, the error detection logic (ex. ECC ch..) raises a false alarm.
- When there is an error, the security guard without catching it. The error propagates and creates confusion.
- The error detection hardware malfunctions in generating appropriate coding. For example, the parity generator may generate a wrong parity bit. This goes unnoticed immediately when the parity checker detects an error, the OS wrongly considers it a genuine error.

(IV) **Heart Beats:**

We have seen some of the symptoms of a dead PC earlier. These are the general symptoms applicable to any computer. In addition, there are some check points which are the heart beats of PCs. By sensing these, the engineer can predict the problem type and determine how to proceed with diagnosis. Two such effective check points are:

- *Memory refresh request:* Refresh in DRAM IC is done at regular interval. For this purpose, refresh signal is generated once every 15 μ sec. If this pulse is present it indicates the following-

- . Microprocessor is alive. Initial start-up is successful. Reset sequence had been completed.
- . Microprocessor firmware has successfully initialized the refresh counter.
- . The refresh logic is functioning properly.
- . the data bus, address bus and control bus are reasonable error free.
- *Timer 0- Ticks*: The PC maintains the time of day. This time is periodically updated by the cooperation between timer 0 and timer interrupt service routine. The timer 0 (PIT) raises Tick periodically and the system uses these interrupt signals to update the time.

5.6 Systematic way of trouble shooting versus adhoc trouble shooting

- *Symptom observation*
- *symptom analysis*
- *fault diagnosis*
- *Fault Rectification*

Adhoc techniques of troubleshooting don't always help an engineer. Systematic trouble shooting is a logical approach. It is a scientific and analytical process. The systematic troubleshooting approach can be divided into the following steps:

- Symptom observation
- symptom analysis
- fault diagnosis
- Fault Rectification

(I) Symptom observation

The first step in troubleshooting a system or peripheral is observing all the symptoms caused by the fault in the system. For some problems, especially for problems due to multiple faults, it will be impossible to locate the exact fault or it will take a long time & thus the downtime will be increased. The time spent on symptoms observation in turn will yield proportional return during fault locating. Clean mind and concentration is essential while troubleshooting a problem. Certain complex problems can be understood only if the engineer has an overall idea of the system functioning of various software routines and sequences performed by POST, BIOS and OS.

(II) Symptom analysis

A careful analysis of the symptoms will give a clue to the fault location process. When there are multiple symptoms the engineers should try to correlate the various symptoms to identify the problem. If any relationship or clue is found, several steps can be skipped during fault location, thereby reducing the downtime considerably. In cases where there is no interrelation between the symptoms of a problem, the engineer should proceed with the fault location, without wasting time in attempting to establish the relationship. If multiple faults are present, then we may be minted by mixed symptoms. It is difficult to predict the presence of multiple faults. Two probable clues are

- Symptoms are not consistent but keep changing
- Certain symptoms vanish suddenly

Troubleshooting a system with multiple faults is a tough task. We may have to repeat the test multiple times. Once multiple fault is suspected, one should be strictly systematic.

(III) Fault diagnosis

It is highly sophisticated scientific process. The most important point is the multi-dimensional view to be applied by the hardware engineer while troubleshooting. The main dimensions are

- *Architecture:*

Certain problems can be visualized properly only when you analyze the problem and the behavior of the computer as a system consisting both hardware and software. Software may be either a system software or an application software. It is not necessary that we should be a programmer. But we should know what the programs do, when they start and stop some activities and when they interact with hardware.

- *Organization:*

Different faults may create the same external symptom. The engineer must distinguish the different faults by a deep analysis of the internal machine status. Every computer has certain unique organizational aspects. Before trouble shooting a computer, the engineer should understand the specific detail of organization of the computer. The computer with same architecture need not have the same organization. The hardware organization refers to functional and physical distribution of various subsystems in the computer. It decided by the computer designers based on the status of computer technology during the design state. Hardware engineer should know the organizational aspects including detailed timing relationship and signal sequences. Even if the engineer fortes all the signals in a computer system, he won't be able to locate the fault if he does not know how correlate the various signal conditions.

Engineering Layout: Certain problems are caused by mere physical layout faults:

Faulty cable, loose connection, open wire, track short, etc. To catch these problems, one must thoroughly analyze the physical aspects. The layout documents to a computer are –

- Circuit diagram
- Board layout diagram
- Cable Signals
- Connector signals list
- Jumper settings

Environment: Certain problems are caused due to environmental conditions and are listed below:

- High Temperature
- DUST
- Magnetic
- Fields Humidity

(IV) Fault Rectification:

Once a problem is diagnosed thoroughly and the fault is traced, the rectification involves skilled mechanical work rather than analytical work. This step involve performing one or more of the actions depending on the result of fault diagnosis:

- Replacing a defective IC or other components
- Replacing a defective PCB
- Cleaning the R/W heads
- Formatting a diskette or hard disk
- Adjustments: mechanical or electrical
- Controlling temperature or improving cooling.

6.0 BASIC Networking Devices and their interfacing

6.1 Network Interfacing Card

In the list of networking devices, NIC stands on first place. Without this device, networking cannot be done. This is also known as network adapter card, Ethernet Card and LAN card. NIC allows our PC to communicate with other PCs. Basically it converts data transmission technology. A PC uses parallel data transmission technology to transmit data between its internal parts while the media that connects this PC with other PCs uses serial data transmission technology. A NIC converts parallel data stream into serial data stream and vice versa serial data stream is get converted in parallel data stream.

Usually all modern PCs have integrated NICs in motherboard. NICs are also available separately. For desktop or server system they are available in adapter format which can be plugged into the available slots of motherboard. For laptop or other small size devices they are available in PCMCIA (Personal Computer Memory Card International Association) card format which can be inserted in PCMCIA slots.

Types of NICs

There are two types of NICs

Media Specific :- Different types of NICs are required to connect with different types of media. For example we cannot connect wired media with wireless NIC card. Just like this, we cannot connect coaxial cable with Ethernet LAN card. We have to use the LAN card that is particularly built for the media type which we have.

Network Design Specific :- A specific network design needs a specific LAN card. For example FDDI, Token Ring and Ethernet have their own distinctive type of NICs card. They cannot use other's NIC card.

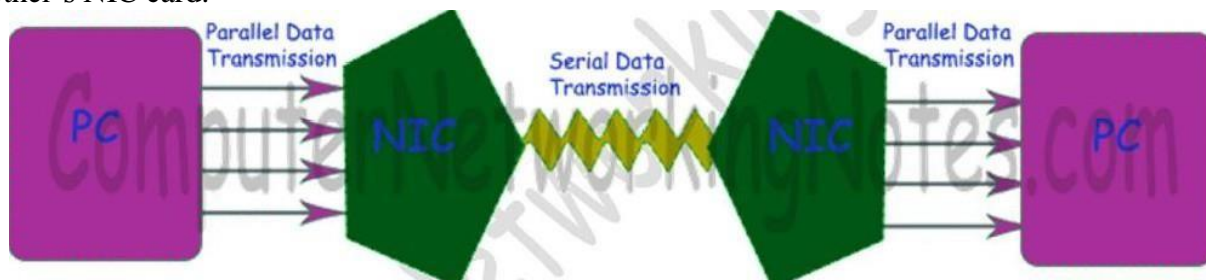

Collision

Collision is the effect of two devices sending transmissions simultaneously in Ethernet. When they meet on the physical media, the signals from each device collide and are damaged. Collision domain is the group of devices that share same collision effects over the Ethernet network. It is a mechanism of removing collision from network. When two or more nodes simultaneously sense the wire and find no signals, and each device places its signal on the wire. These signals would collide in wire and a collision will occur.

Before placing any signal in wire, NIC (Network Interface Card) examines wire for any existing signal. This method is known as CS (Carrier Sense). If two NICs sense wire on exactly same time and see no signal then both will place their signals in wire. This is known as MA (Multiple Access). If the NICs see a collision for their transmitted signals, they have to resend the signals. In this situation, each NIC that was transmitting a frame when a collision occurred creates a special signal, called a jam signal, on the wire, waits a small random time period, and examines the wire again. If there is no signal in the wire, NIC will retransmit its original signals again.

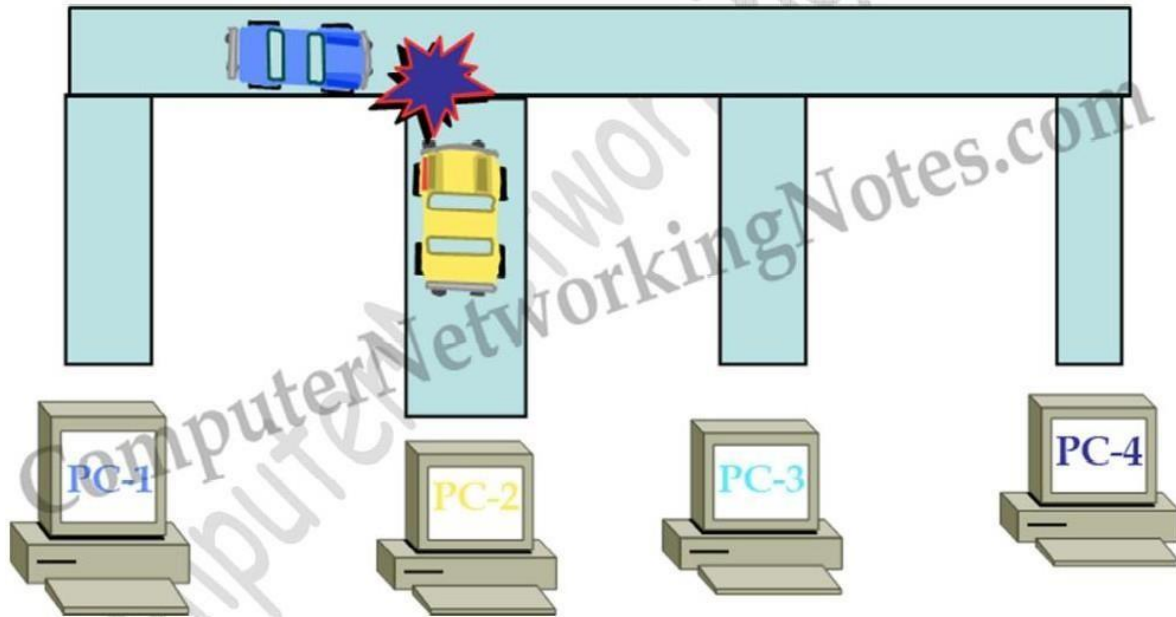

The more devices you place on a segment, the more likely you are going to experience the collisions. More devices means more random time interval, creating even more collisions, gradually slowing down a device's access when trying to transmit the data.

6.2 Networking Interconnection Devices

- . Hub
- . Switch
- . Router

6.2.1 Hub

Hub is a device works on the physical layer of OSI Models which create single broadcast domain & single collision domain. It is a layer 1 device. Hub use the method of Broadcast data transmission.

Characteristics of HUB:-

- 1) Hub creates single Broadcast Domain.
- 2) Hub creates single Collision Domain.

HUB is used to connect multiple computers in a single workgroup LAN network. Typically HUBs are available with 4,8,12,24,48 ports. Based on port type, there are two types of HUB:-

Ethernet HUB :- In this type of HUB all ports have RJ-45 connectors.

Combo HUB :- In this type of HUB ports have several different types of connectors such RJ-45, BNC, and AUI. HUBs generally have LED (light-emitting diode) indicator lights on each port to indicate the status of link, collisions, and other information. To understand the functionality of hub let's take an example from real life.

There are four friends who share everything. One of them finds a photo of Amitabh Bachchan. To share this with friends, he will make three photo copies from Xerox machine and give one copy to each friend. He doesn't need a copy of photo for himself as he has the original one. Now change the characters in this example. Replace friends with HUB's port, photo with data signal and Xerox machine with HUB. There is a HUB which has four ports. Ports share everything. One port received data signal from its connected device. It will make three copies of data signal from HUB and give one copy to each port. Receiver port doesn't need a copy of data signal for itself as it has it the original version. When a hub receives signal

on its port, it repeats the signal and forwards that signal from all ports except the port on which the signal arrived. There are two types of HUB

Passive HUB :- It forwards the data signal from all ports except the port on which signal arrived. It doesn't interfere in data signal.

Active HUB :- It also forwards the data signal from all ports except the port on which signal arrived. But before forwarding, it improves quality of data signal by amplifying it. Due to this added features active HUB is also known as repeaters.

Usually HUB has one or more uplink ports that is used to connect it with another HUB. Right cable type is required to connect two HUBs. Logically HUB creates a star topology where it sits in the center of the topology and all connected systems stays at the points of the star.

First hub's port	Second hub's port	Cable type
Uplink	Uplink	Crossover cable
Uplink	regular	Standard cable
Regular	Uplink	Standard cable
Regular	Regular	Cross cable

Physically HUB creates a bus topology where all connected systems share the same bus connection. There are two similar devices to HUB, MAU and PatchPanel.

6.2.2 Switch

Switch is a device works on the Data Link Layer of OSI Models which create single broadcast & multiple collision domains. It is a layer 2 device & works on MAC address. Switch use the method of Unicast data transmission. Switch maintain a table which called MAC Address Table. In this table switch store Mac Address & Port no. of all the hosts attached on this network. That's why Switch is more intelligent. Switch stores the MAC table in a IC (integrated chip) called ASIC (Application Specific Integrated Circuit).

Characteristics of SWITCH:-

- 1) Switch create single Broadcast Domain.
- 2) Switch create multiple Broadcast Domain.

Switch is also used to connect multiple computers together in a LAN segment. Switches available with 4,8,12,24,48,64 ports. Each switch port has a separate collision domain. Switch works at layer two in OSI Layer model. At layer two data signals are formatted in frames. When a switch receives frame, it checks FCS (Frame checksum sequence) field in it. Switch process the frame only if it is valid. All invalid frames are automatically dropped. All valid frames are processed and forwarded to their destination MAC address. Switch makes their switching decisions in hardware by using application specific integrated circuits (ASICs). Unlike generic processor such as we have in our PC, ASICs are specialized processors built only to perform very few particular tasks. In cisco switch ASICs has single task, switch frames blazingly fast. For example an entry level catalyst 2960 switch has frame rate of 2.7 million frames per second. Higher end switches have higher FPS rate such as Catalyst 6500 has a rate of 400 million FPS rate Switches support three methods of switching.

1. Store and Forward
2. Cut and Through
3. Fragment Free

Store and Forward

This is the basic mode of switching. In this mode Switch buffers entire frame into the memory and run FCS (Frame Check Sequence) to ensure that frame is valid and not corrupted. A frame less than 64bytes and higher than 1518bytes is invalid. Only valid frames are processed and all

invalid frames are automatically dropped. Among these three methods, this method has highest latency. Latency is the time taken by device in passing frame from it.

Cut and Through

Cut and Through method has lowest latency. In this method Switch only read first six bytes from frame after the preamble. These six bytes are the destination address of frame. This is the fastest method of switching. This method also process invalid frames. Only advantage of this method is speed.

Fragment Free

This is a hybrid version of *Store and Forward method* and *Cut and Through method*. It takes goodies from both methods and makes a perfect method for switching. It checks first 64 bytes of frame for error. It processes only those frames that have first 64bytes valid. Any frame less than 64 bytes is known as **runt**. Runt is an invalid frame type. This method filters **runt** while maintaining the speed.

6.2.3 Router

Router is a device works on the Network Layer of OSI Models which creates no Broadcast Domain & Collaisen Domain. Router prevent Broadcast. It is a Layer 3 device works on IP Address.

Router has mainly 2 types of interface.Ethernet or LAN interface & Serial or WAN interface.

Router maintain a table called Routing Table. It holds the Information of IP Addresses, Interface & HOP of all the hosts connected to this network.HOP means jump. How many router I have to jump to go to the recipient that is HOP. Basically routers are used :-

- To connect different network segments.
- To connect different network protocols such as IP and IPX.
- To connect several smaller networks into a large network (known as internetwork)
- To break a large network in smaller networks (Known as subnet usually created to improve the performance or manageability)
- To connect two different media types such as UTP and fiber optical.
- To connect two different network architectures such as token ring and Ethernet.
- To connect LAN network with Telco company's office (Known as DTE device).
- To access DSL services (known as DSL Router).

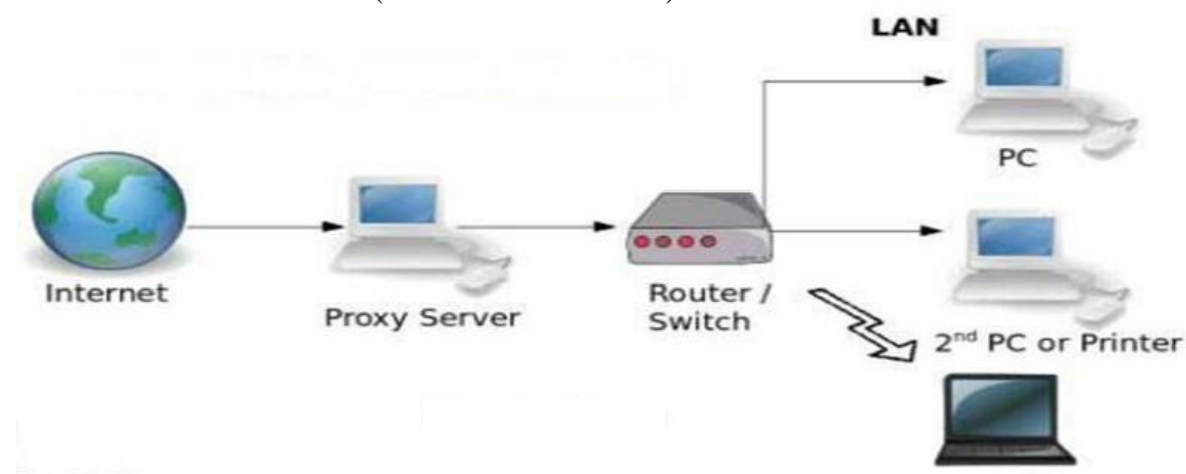

6.3 Types of Network Cable

In networks using cable-based media, there are three basic choices:

- . Twisted pair
- . Coaxial
- . Fiber-optic

Twisted pair and coaxial cables both use copper wire to conduct the signals electronically; fiber-optic cable uses a glass or plastic conductor and transmits the signals as light.

(A) Twisted Pair Cable

- Two main types of twisted-pair cabling are in use today: Unshielded Twisted Pair (UTP) and Shielded Twisted Pair (STP). UTP is significantly more common than STP and is used for most networks. Shielded twisted pair is used in environments in which greater resistance to EMI and attenuation is required. The greater resistance comes at a price, however. The additional shielding, plus the need to ground that shield (which requires special connectors), can significantly add to the cost of a cable installation of STP. STP provides the extra shielding by using an insulating material that is wrapped around the wires within the cable. This extra protection increases the distances that data signals can travel over STP but also increases the cost of the cabling.
- There are several categories of twisted-pair cabling. The early categories are most commonly associated with voice transmissions. The categories are specified by the Electronic Industries Association/Telecommunications Industry Association (EIA/TIA). EIA/TIA is an organization that focuses on developing standards for electronic components, electronic information, telecommunications, and Internet security. These standards are important to ensure uniformity of components and devices.

EIA/TIA has specified a number of categories of twisted-pair cable:

- *Category 1:* Voice-grade UTP telephone cable. Due to its susceptibility to interference and attenuation and its low bandwidth capability, Category 1 UTP is impractical for network applications..
- *Category 2:* Data-grade cable that can transmit data up to 4Mbps. Category 2 cable is too slow for networks. It is unlikely that you will encounter Category 2 on any network today.
- *Category 3:* Data-grade cable that can transmit data up to 10Mbps with a possible bandwidth of 16MHz. For many years, Category 3 was the cable of choice for twisted-pair networks. As network speeds pushed the 100Mbps speed limit, Category 3 became ineffective.
- *Category 4:* Data-grade cable that has potential data throughput of 16Mbps. Category 4 cable was often implemented in the IBM Token Ring Network. Category 4 cable is no longer used.
- *Category 5:* Data-grade cable that typically was used with Fast Ethernet operating at 100Mbps with a transmission range of 100 meters. Although Category 5 was a popular media type, this cable is an outdated standard. Newer implementations use the 5e standard. Category 5 provides a minimum of 100MHz of bandwidth. Category 5, despite being used primarily for 10/100 Ethernet networking, can go faster. The IEEE 802.11ae standard specifies 1000Mbps over Category 5 cable..
- *Category 5e :* Data-grade cable used on networks that run at 10/100Mbps and even up to 1000Mbps. Category 5e cabling can be used up to 100 meters, depending on the implementation and standard used. Category 5e cable provides a minimum of 100MHz of bandwidth.

- *Category 6:* High-performance UTP cable that can transmit data up to 10Gbps. Category 6 has a minimum of 250MHz of bandwidth and specifies cable lengths up to 100 meters with 10/100/1000Mbps transfer, along with 10Gbps over shorter distances. Category 6 cable typically is made up of four twisted pairs of copper wire, but its capabilities far exceed those of other cable types. Category 6 twisted pair uses a longitudinal separator, which separates each of the four pairs of wires from each other. This extra construction significantly reduces the amount of crosstalk in the cable and makes the faster transfer rates possible.
- *Category 6a:* Also called augmented 6. Offers improvements over Category 6 by offering a minimum of 500MHz of bandwidth. It specifies transmission distances up to 100 meters with 10Gbps networking speeds.

Category	Common Application
1	Analog voice applications
2	1Mbps
3	16Mbps
4	20Mbps
5	100Mbps
5e	1000Mbps
6	10/100/1000Mbps plus 10Gbps
6a	10Gbps and beyond networking

(B) Coaxial Cable

Coaxial cable, or coax as it is commonly called, has been around for a long time. Coax found success in both TV signal transmission and network implementations. Coaxial cable is constructed in this way to add resistance to attenuation (the loss of signal strength as the signal travels over distance), crosstalk (the degradation of a signal, caused by signals from other cables running close to it), and EMI. Two types of coax are used in networking: thin coax, also known as thin net, and thick coax, also known as thick net. Neither is particularly popular anymore, but you are most likely to encounter thin coax. Thick coax was used primarily for backbone cable. It could be run through plenum spaces because it offered significant resistance to EMI and crosstalk and could run in lengths up to 500 meters. Thick coax offers speeds up to 10Mbps, far too slow for today's network environments

(C) Fiber – optic Cable

In many ways, fiber-optic media addresses the short comings of copper-based media. Because fiber-based media use light transmissions instead of electronic pulses, threats such as EMI, crosstalk, and attenuation become nonissues. Fiber is well suited for the transfer of data, video, and voice transmissions. In addition, fiber-optic is the most secure

of all cable media. Anyone trying to access data signals on a fiber-optic cable must physically tap into the medium. Given the composition of the cable, this is a particularly difficult task.

Two types of fiber-optic cable are available:

- *Multimode fiber* : Many beams of light travel through the cable, bouncing off the cable walls. This strategy actually weakens the signal, reducing the length and speed at which the data signal can travel.
- *Single-mode fiber*: Uses a single direct beam of light, thus allowing for greater distances and increased transfer speeds.

NETWORK CABLE

STRAIGHT CABLE:-

END 1

- 1) BLUE
- 2) GREEN
- 3) BROWN
- 4) ORANGE
- 5) BLUE on WHITE
- 6) GREEN on WHITE
- 7) BROWN on WHITE
- 8) ORANGE on WHITE

END 2

- 1) BLUE
- 2) GREEN
- 3) BROWN
- 4) ORANGE
- 5) BLUE on WHITE
- 6) GREEN on WHITE
- 7) BROWN on WHITE
- 8) ORANGE on WHITE

Straight cable is used to connect pc to hub, pc to switch, router to hub through Ethernet & router to switch through Ethernet.

CROSS CABLE:-

END 1

- 1) ORANGE
- 2) BLUE
- 3) GREEN
- 4) ORANGE on WHITE
- 5) BLUE on WHITE
- 6) BROWN
- 7) GREEN on WHITE
- 8) BROWN on WHITE

END 2

- 1) GREEN
- 2) BROWN
- 3) ORANGE
- 4) ORANGE on WHITE
- 5) BLUE on WHITE
- 6) BLUE
- 7) GREEN on WHITE
- 8) BROWN on WHITE

It is used for to connect pc to pc, hub to hub, switch to switch, switch to hub, router to router through Ethernet.

ROLE OVER CABLE:-

END 1

- 1) **ORANGE**
- 2) BLUE
- 3) GREEN
- 4) BROWN
- 5) **ORANGE** on WHITE
- 6) **BLUE** on WHITE
- 7) GREEN on WHITE
- 8) BROWN on WHITE

END 2

- 1) **BROWN** on WHITE
- 2) GREEN on WHITE
- 3) BLUE on WHITE
- 4) **ORANGE** on WHITE
- 5) BROWN
- 6) GREEN
- 7) BLUE
- 8) **ORANGE**

It is used for to connect a router through console port to a pc through serial port.

6.4 Types of Network Connector

A variety of connectors are used with the associated network media. Media connectors attach to the media and allow the physical connection into computing device. Many of the fiber and the copper networks are used for sending data from the one place of the world to the corner of it. There are so many connections are out there which are most commonly found in the modern era. These connectors have some specific cables as well. The cables that we use at the homes are important since they might be the base of the connection that is being used. When the house is being build, and the networking is being selected from the scratch, it is very vital to know that the cables selected are of the right type so that no difficulty can be seen in the future. Here are some connectors and the cables which have some specific characteristics;

- (I) BNC connectors are associated with coaxial media and 10Base2 networks. BNC connectors are not common as they once were, but they still are used on some network cards and older hubs. Common BNC connectors include a barrel connector, T-connector and terminator.
- (II) When one starts working with the fiber, he would notice that it contains many types. There are various kinds of the connectors which are connected at the end of the cables. They are mentioned as Connectors: SC, ST and LC: The ST uses a half-twist bayonet type of lock. The SC uses a push-pull connector similar to common audio and video plugs and sockets. The LC connectors have a flange on top, similar to an RJ-45 connector, that aids secure. MT-RJ is a popular connector for two fibers in a very small factor.
- (III) It is pretty obvious that if one decides to do all the cabling himself, he would have a different way of doing it than others. Hence one can face many problems while doing so. Due to that reasons, there are some standards which have been created and linked to the devices so everyone follows the same. Some of them are associated to the twisted pair cabling. These are; Connectors: RJ-11, RJ-45: there are two connectors which are associated to the twisted cables. RJ (Registered jack)-11 connectors are

small plastic connectors used on telephone cables. They have capacity for six small pins. The RJ-45 connectors are used with twisted-pair cabling and have capacity for eight small pins.

(IV) F-type connectors are screw-on connections used to attach coaxial cable to devices. This includes RG-59 and RG-6 cables. F-type connectors are commonly associated with connecting Internet modems to cable or satellite Internet service provider's (ISPs') equipment.

- ▶ RJ-11 connectors are used with standard phone lines and are similar in appearance to RJ-45 connectors used in networking. However, RJ-11 connectors are smaller.
- ▶ RJ-45 connectors are used with UTP cabling.
- ▶ F-type connectors are used to connect coaxial cable to devices such as Internet modems.
- ▶ Fiber-optic cabling uses a variety of connectors, but SC and ST are more commonly used than others.
- ▶ SC and ST connectors are associated with fiber cabling. ST connectors offer a twist-type attachment, whereas SCs have a push-on connector.
- ▶ LC and MT-RJ are other types of fiber-optic connectors.
- ▶ UTP cabling is the most common type used on today's networks. For greater speeds, distances, and resistance to interference, fiber-optic cable provides an increasingly affordable alternative.
- ▶ 10BaseT networks use UTP cable and RJ-45 connectors to transfer data at up to 10Mbps.
- ▶ 10BaseFL networks use fiber-optic cabling and can span distances of up to 2 km.
- ▶ 100BaseTX networks use RJ-45 connectors and use Category 5 STP or UTP cable.
- ▶ 100BaseT4 networks use Category 3, 4, and 5 cable with RJ-45 connectors.
- ▶ 100BaseFX uses fiber-optic cable and often uses SC or ST connectors.
- ▶ 1000BaseSX and 1000BaseLX offer 1000Mbps transfer speeds using fiber-optic cable.
- ▶ 1000BaseCX offers 1000Mbps transfer speeds over shielded copper cable. Distances are restricted to 25 meters.
- ▶ 1000BaseTX offers 1000Mbps transfer speeds over UTP cable up to a maximum of 100 meters.

Straight Versus Crossover Cable

Two types of cables are used to connect devices to hubs and switches: crossover cables and straight-through cables. The difference between the two types is that in a crossover cable, two of the wires are crossed; in a straight-through cable, all the wires run straight through.

Vertical Cable

Vertical cable, or backbone cable, refers to the media used to connect telecommunications rooms, server rooms, and remote locations and offices. Vertical cable may be used to connect locations outside the local LAN that require high-speed connections. Therefore, vertical cable is often fiber-optic cable or high-speed UTP cable. Figure 2.16 shows the relationship between horizontal cable and vertical cable.

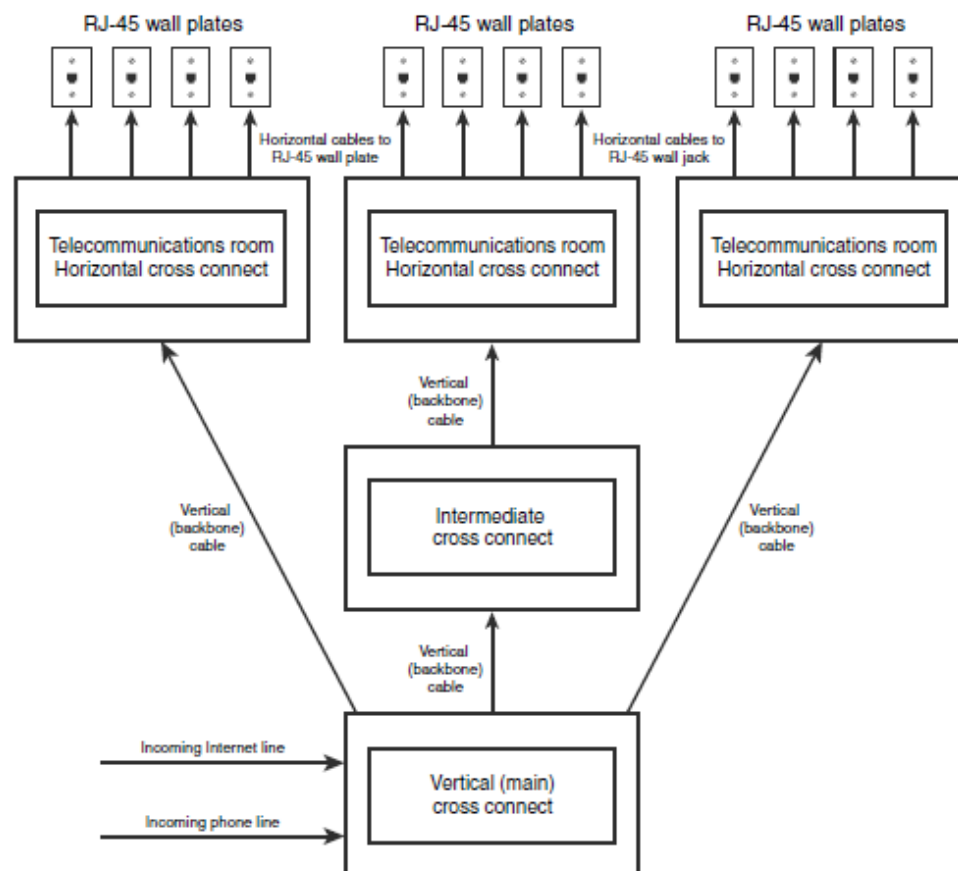

FIGURE 2.16 Vertical and horizontal cabling.

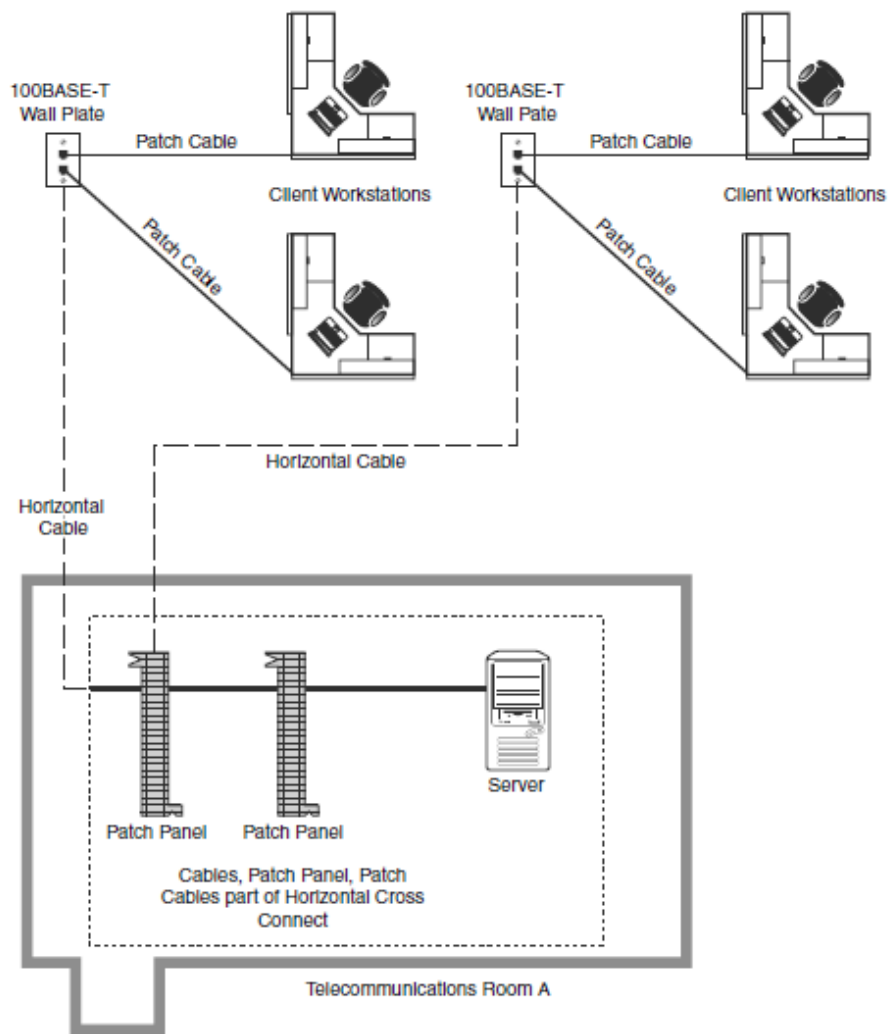

FIGURE 2.15 Horizontal cabling.

Horizontal cabling runs within walls and ceilings and therefore is called *permanent cable* or *structure cable*. The length of cable running from the horizontal connects and the telecommunication outlet on the client side should not exceed 90 meters. Patch cables used typically should not exceed 5 meters. This is due to the 100-meter distance limitation of most UTP cable.

VI/SEM/CSE/2016 (W)
NEW

COMPUTER SYSTEM MANAGEMENT PLANNING
AND MAINTENANCE

Sub Code-CST-604

Full Marks : 70

Time : 3 hours

Answer any **five** questions

The figures in the right-hand margin indicate marks

1. (a) What do you mean by false flooring? 2
- (b) Discuss the various computer related jobs carried out in an organization. 5
- (c) Define UPS. Explain different types of UPS available with diagram. 7
2. (a) Define NIC. 2
- (b) What are different types of slots present in motherboard? 5
- (c) Explain different types of network cable with their connectors. 7

(2)

3. (a) Define CMOS. 2
- (b) Define SMPS. Explain SMPS with diagram. 5
- (c) What do you mean by hardware maintenance ?
Explain different types of maintenance. 7
4. (a) What do you mean by firmware ? 2
- (b) What are different network connecting
devices used ? Explain each with diagram. 5
- (c) Explain the various steps for assembling the
PC. 7
5. (a) Define Keyboard. 2
- (b) Define HDD. Explain different parts of HDD
with diagram. 5
- (c) Define BIOS. Explain the work of BIOS. 7
6. (a) Define CVT. 2
- (b) What is POST ? Explain it. 5
- (c) Explain different components available in
motherboard with neat diagram. 7
7. (a) Point out any four vendors in computer hard-
ware. 2

(3)

- (b) What are different types of printer available ?
Explain their trouble shooting. 5
- (c) What do you mean by trouble shooting ?
Explain the systematic way of trouble
shooting. 7