

# **PNS SCHOOL OF ENGINEERING & TECHNOLOGY**



*PRACTICAL MANUAL*

# **MECHANICAL ENGINEERING DRAWING**

*3<sup>RD</sup> SEM MECHANICAL ENGINEERING*



**PREPARED BY**

**ER SUBARNA KESHARI SINGH**









# **INTRODUCTION SYLLABUS**

---



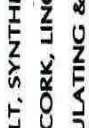









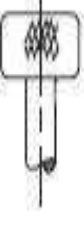

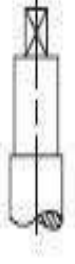
## **MACHINE DRAWING CONVENTIONS**

- Need for drawing conventions –Introduction to IS conventions.
- Conventional representation of materials, common machine elements and parts such as screws, nuts, bolts, keys, gears.
- Methods of dimensioning, general rules for sizes and placement of dimensions for holes, canters curved and tapered features.
- Title boxes, their size, location and details -common abbreviations & their liberal usage
- Types of Drawings –working drawings for machine parts.

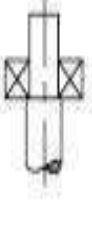









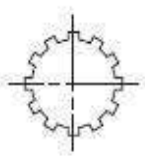

# CONVENTIONAL REPRESENTATION OF MATERIALS

TYPE	CONVENTION	MATERIALS
METALS		STEEL, CAST IRON, COPPER AND ITS ALLOYS, ALUMINIUM AND ITS ALLOYS, ETC
		LEAD, ZINC, TIN, WHITE-METAL, ETC
GLASS		GLASS
PACKING AND INSULATING MATERIALS		PORCELAIN, STONEWARE, MARBLE, SLATE, ETC
		ASBESTOS, FIBRE, FELT, SYNTHETIC RESIN PRODUCTS, PAPER, CORK, LINOLEUM, RUBBER, LEATHER, WAX, INSULATING & FILLING MATERIALS
LIQUIDS		WATER, OIL, PETROL, KEROSENE, ETC
WOOD		WOOD, PLYWOOD, ETC
CONCRETE		

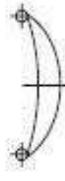
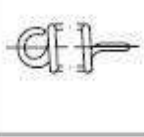
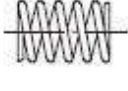
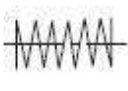
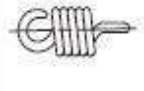

# CONVENTIONAL REPRESENTATIONS OF MACHINE ELEMENTS

Title	Subject	Convention
Straight knurling		
Diamond knurling		
Square on shaft		
Holes on circular pitch		
Bearings		
External screw threads (Detail)		
Internal screw threads (Detail)		
Screw threads (Assembly)		

# CONVENTIONAL REPRESENTATIONS OF MACHINE ELEMENTS

Title	Subject	Convention	Diagrammatic Representation
Splined shafts			
Interrupted views			
			
Semi-elliptic leaf spring			
Semi-elliptic leaf spring with eyes			
Cylindrical compression spring			
Cylindrical tension spring			

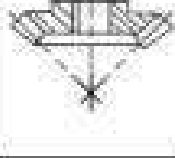
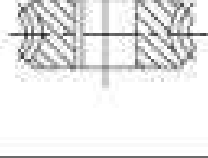
(b)

Title	Convention
Spur gear	
Bevel gear	
Worm, whorl	
Worm	

## DRAWING OF MACHINE ELEMENTS AND SIMPLE PARTS

Selection of Views, additional views for the following machine elements and parts with every drawing proportion.

- **Screwed fasteners:** Popular forms of Screw threads, bolts, nuts, stud bolts, tap bolts, set screws.
- **Keys, Cotters and Pin joints:**
  - Saddle keys, sunk keys
  - Cotter joint with sleeve, cotter joint with socket & spigot ends, cotter joint with a gib.
  - iii) knuckle joint
- **Riveted joints** for plates
- **Shaft couplings:**
  - Rigid couplings-sleeve or muff couplings, Flanged couplings
  - Flexible couplings-Bushed pin type flanged coupling, compression coupling
  - iii) Dis-engaging couplings-claw coupling, cone coupling
  - iv) Non-Aligned couplings-Universal coupling (Hooke's Joint), Oldham coupling, cushion coupling & spigot and socket pipe joint.
- **Bearings:** Journal, pivot and collar and foot step bearings.

# SCREW FASTENERS

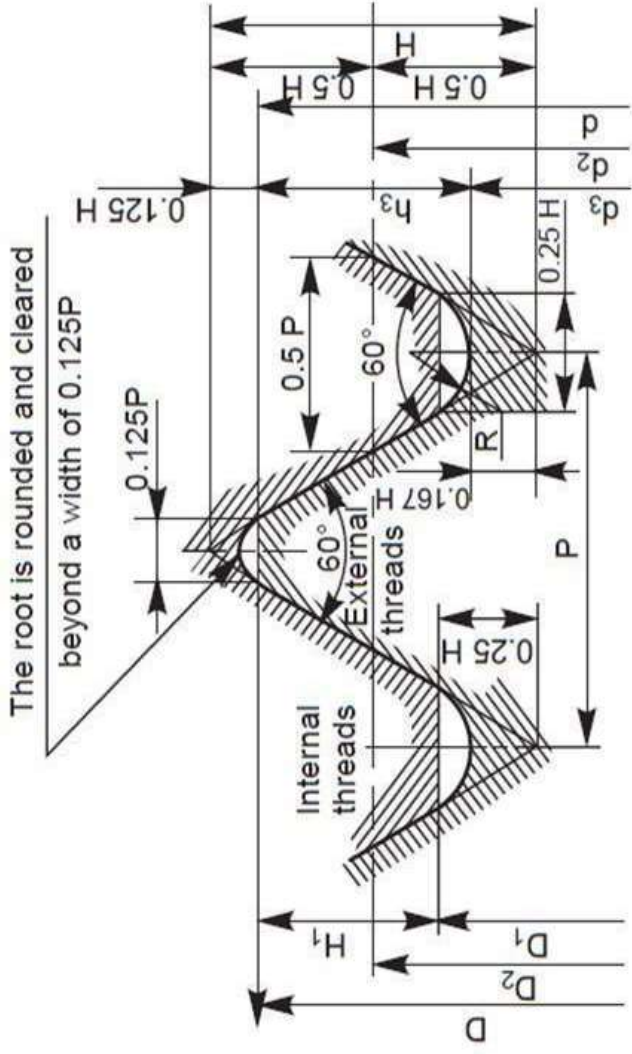

The root is rounded and cleared beyond a width of  $0.125P$

Internal thread diameters  
 $D$  - Major diameter  
 $D_2$  - Pitch diameter  
 $D_1$  - Minor diameter

External thread diameters  
 $d$  - Major diameter  
 $d_2$  - Pitch diameter  
 $d_3$  - Minor diameter

## Metric screw thread

$$P = \text{Pitch}$$

$$H = 0.86 P$$

$$D = d = \text{Major diameter}$$

$$D_2 = d_2 = d - 0.75H$$

$$D_1 = d_2 - 2(H/2 - H/4) = d - 2H_1 = d - 1.08P$$

$$d_3 = d_2 - 2(H/2 - H/6)$$

$$= d - 1.22P$$

$$H_1 = (D - D_1)/2 = 5H/8 = 0.54P$$

$$h_3 = (d - d_3)/2 = 17/24H = 0.61P$$

$$R = H/6 = 0.14P$$



# TYPES OF FORM OF THREADS

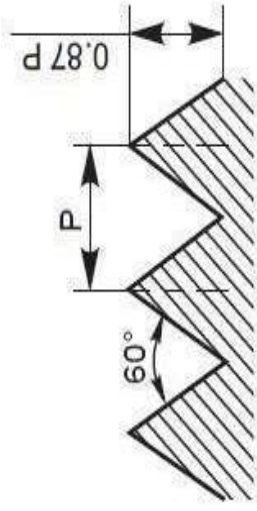

Sharp V

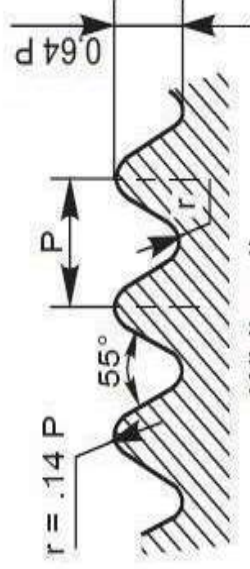

Whitworth

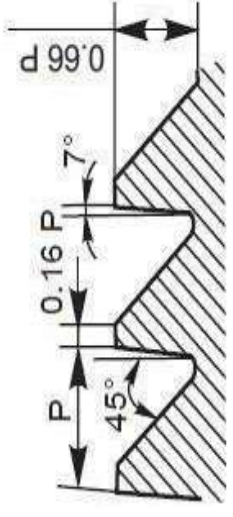

Buttress

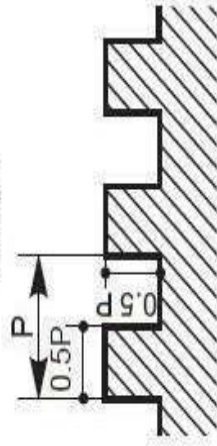

Square

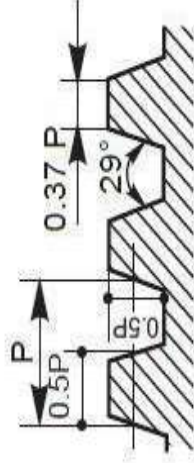

ACME

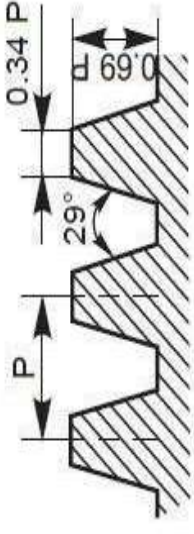

Worm

Types of thread profiles



# BOLTED JOINT

## Drawing Hexagonal ( Bolt Head ) Nut

Major or nominal diameter of bolt =  $D$

Thickness of nut,  $T = D$

Width of nut across flat surfaces,  $W = 1.5D + 3 \text{ mm}$

Radius of chamfer,  $R = 1.5D$

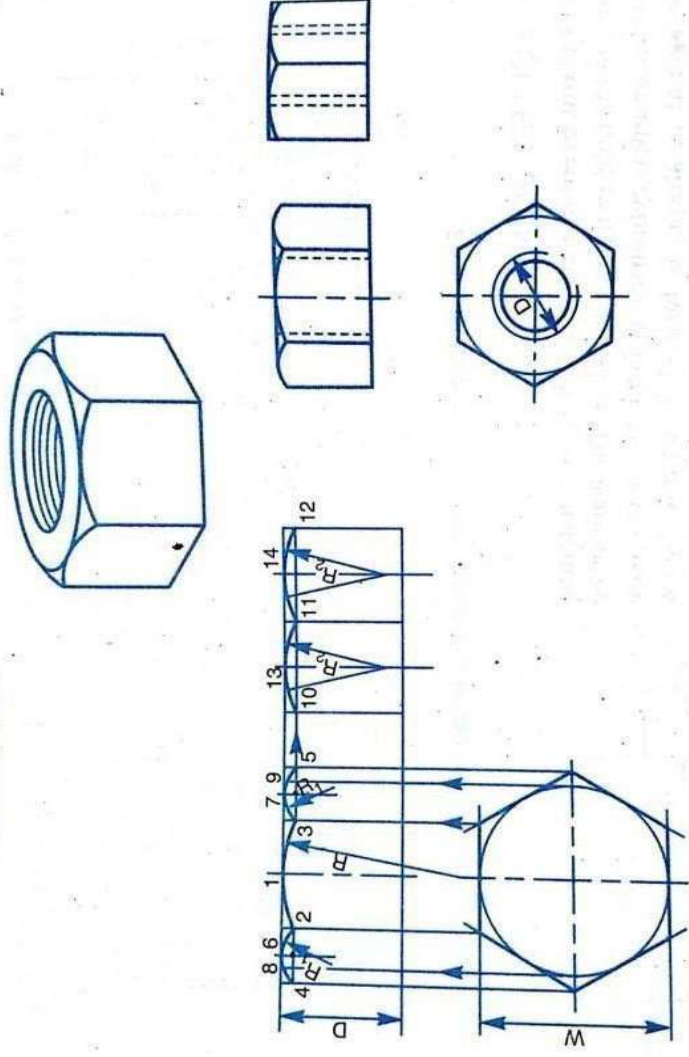
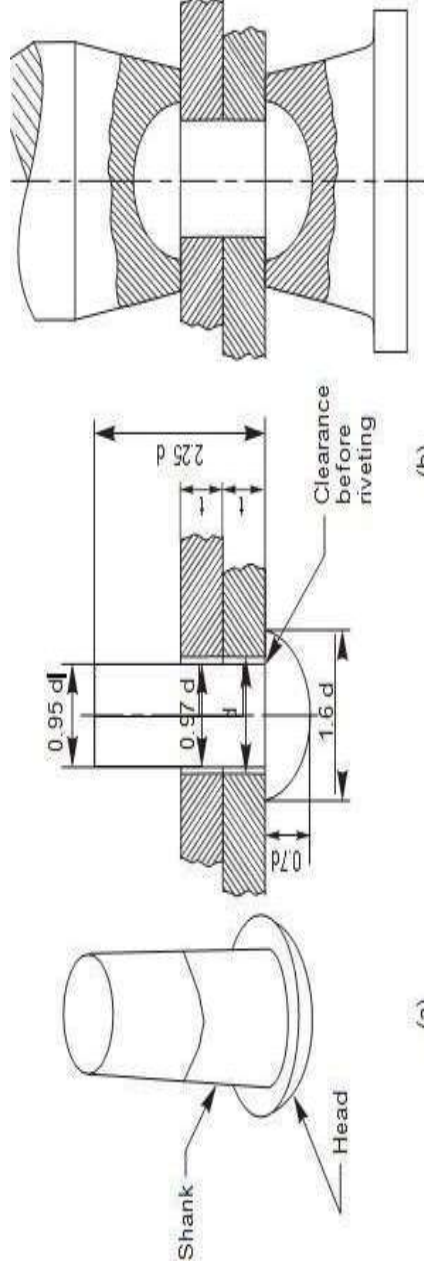

Fig. 5.12 Method of drawing views of a hexagonal nut (Method I)



# RIVETTED JOINTS

## Rivet



## Types of rivet heads

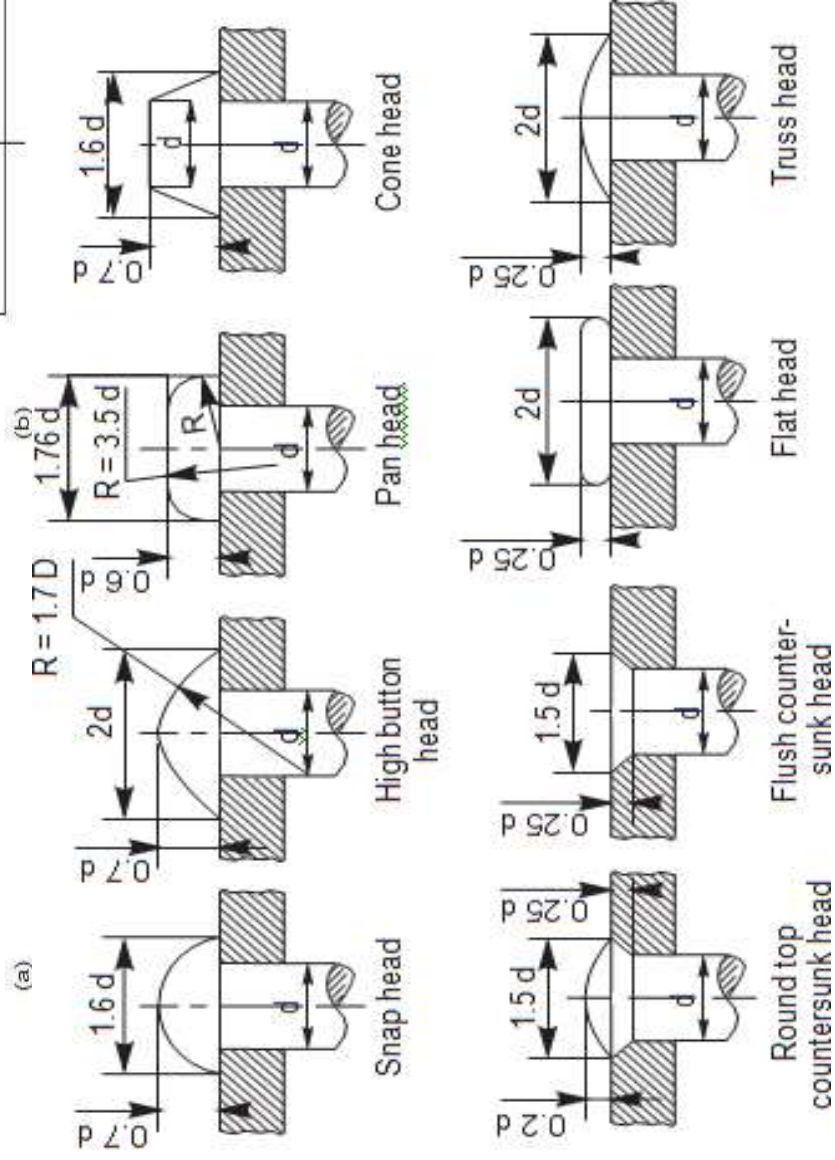

# RIVETTED JOINTS

## Lap Joints

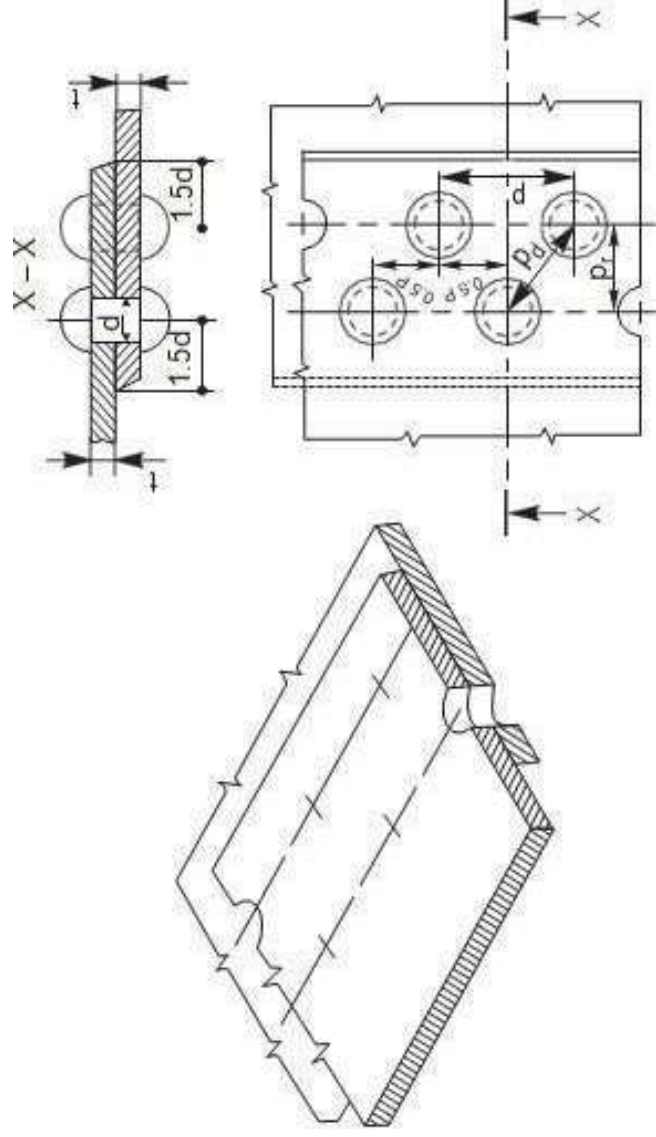

# BUTT JOINTS

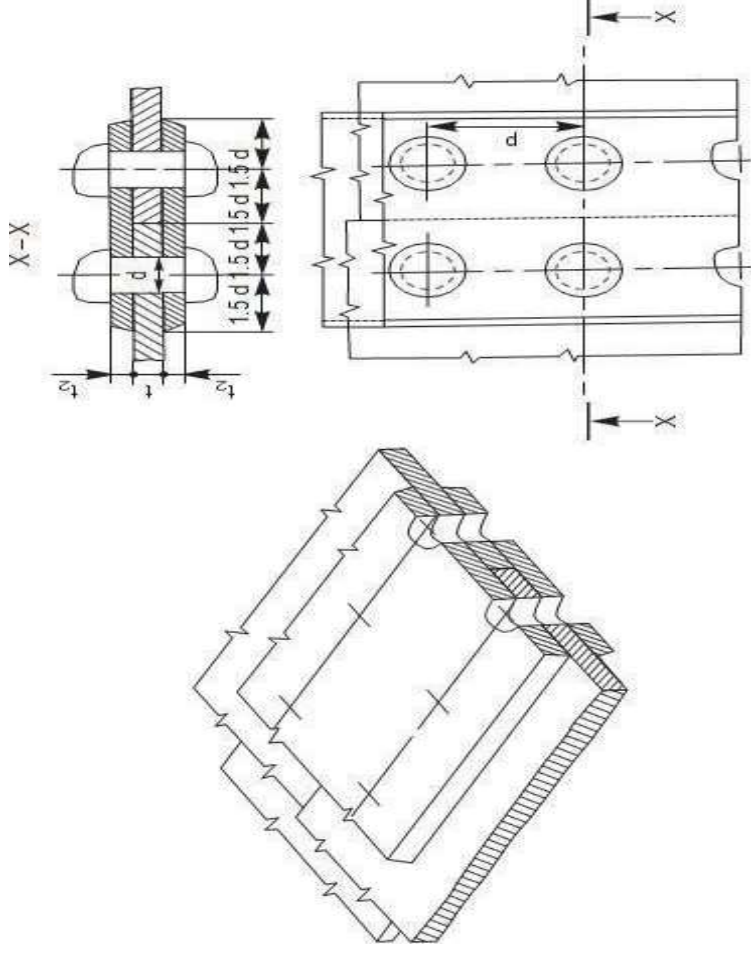

Single riveted, double strap butt joint

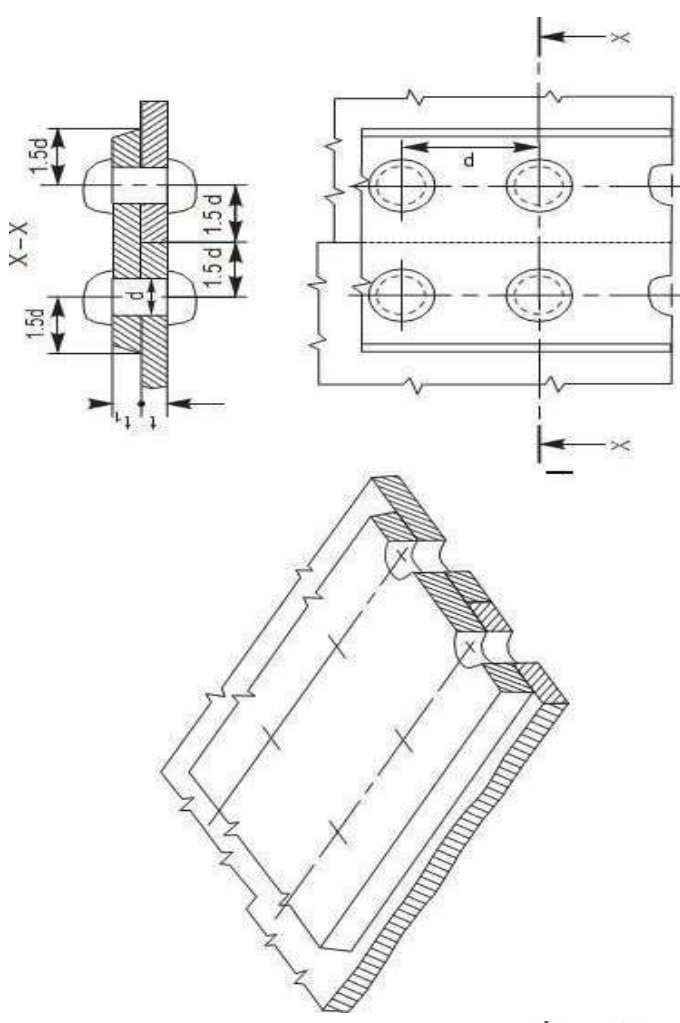

Single riveted, single strap butt joint

# BUTT JOINTS

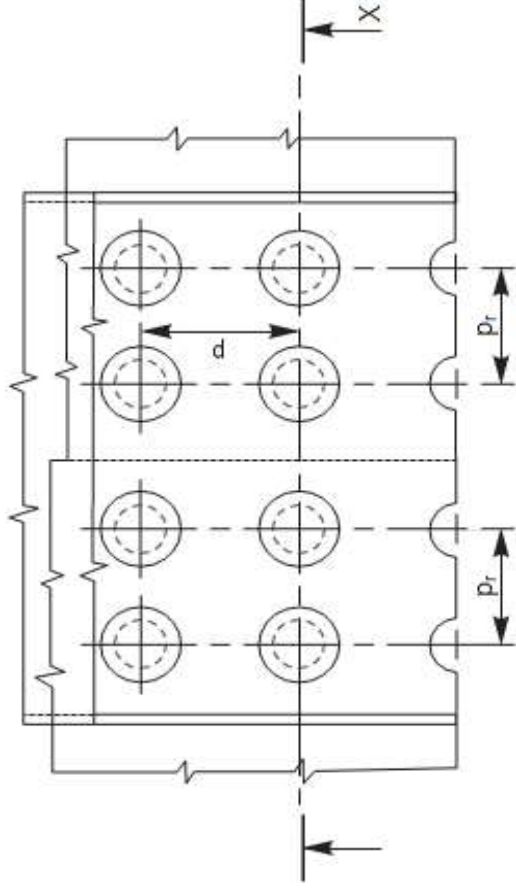
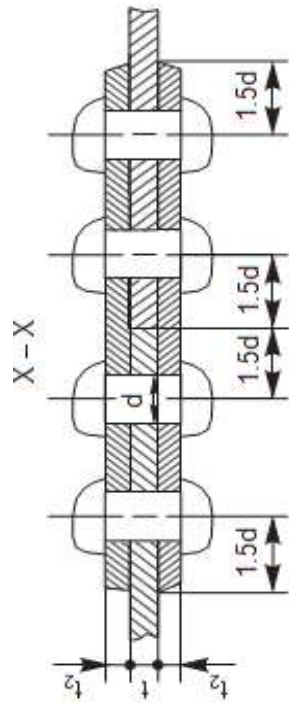

Double riveted, double strap chain butt joint

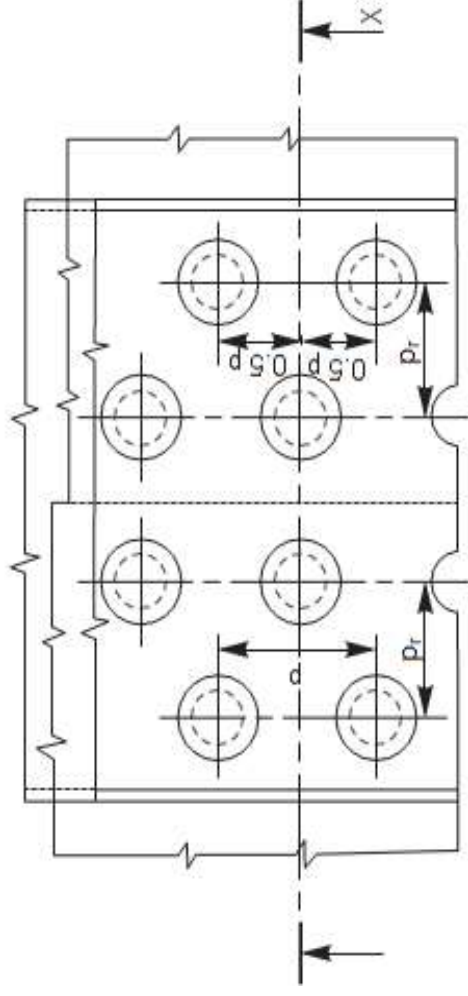
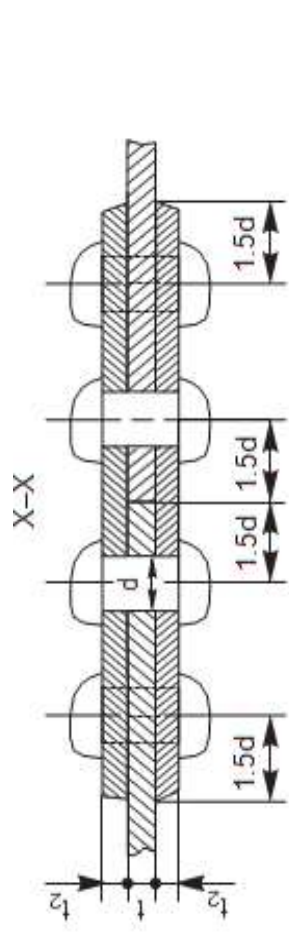

Double riveted, double strap zig-zag butt joint



# CONNECTING ROD

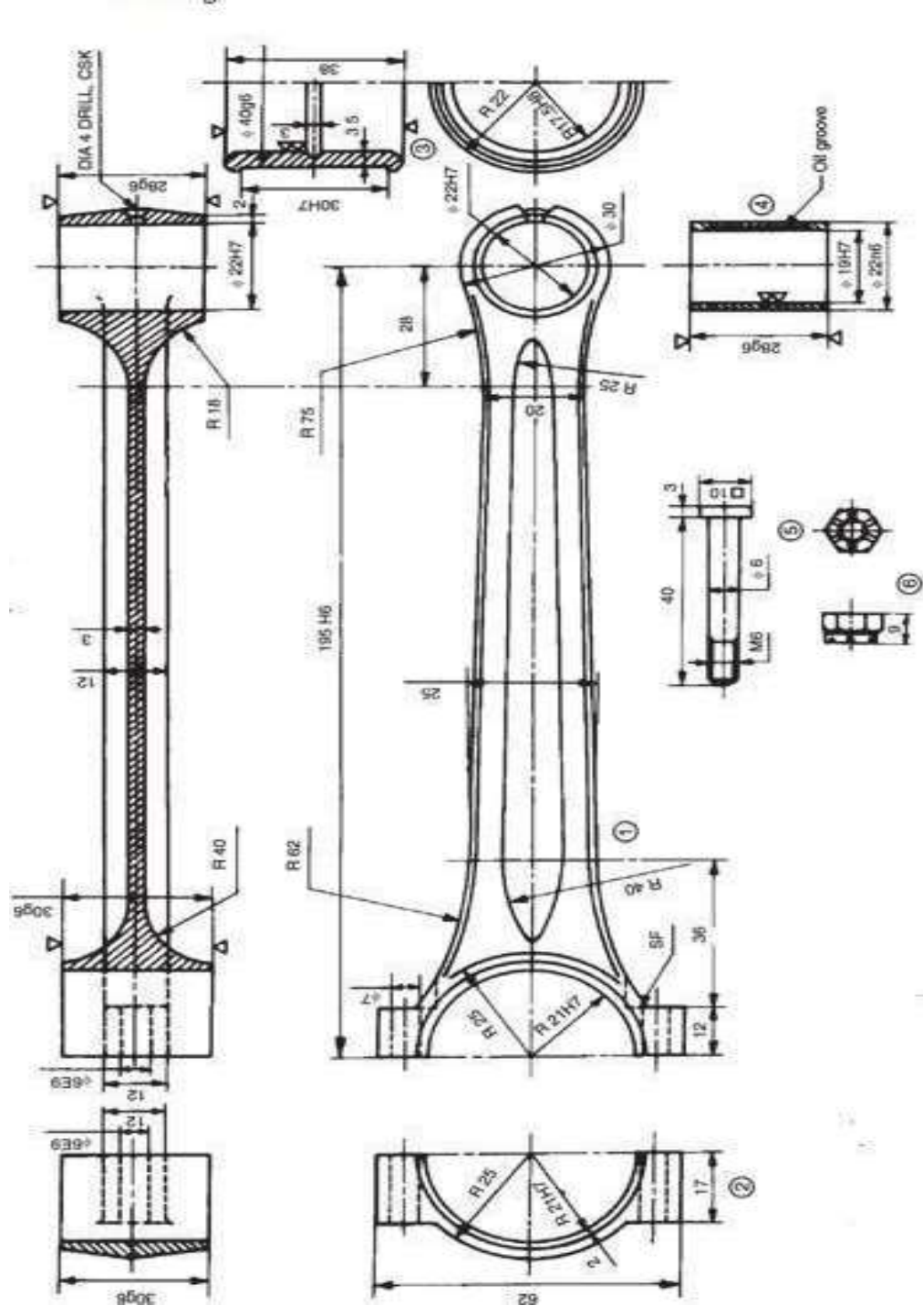



# CONNECTING ROD

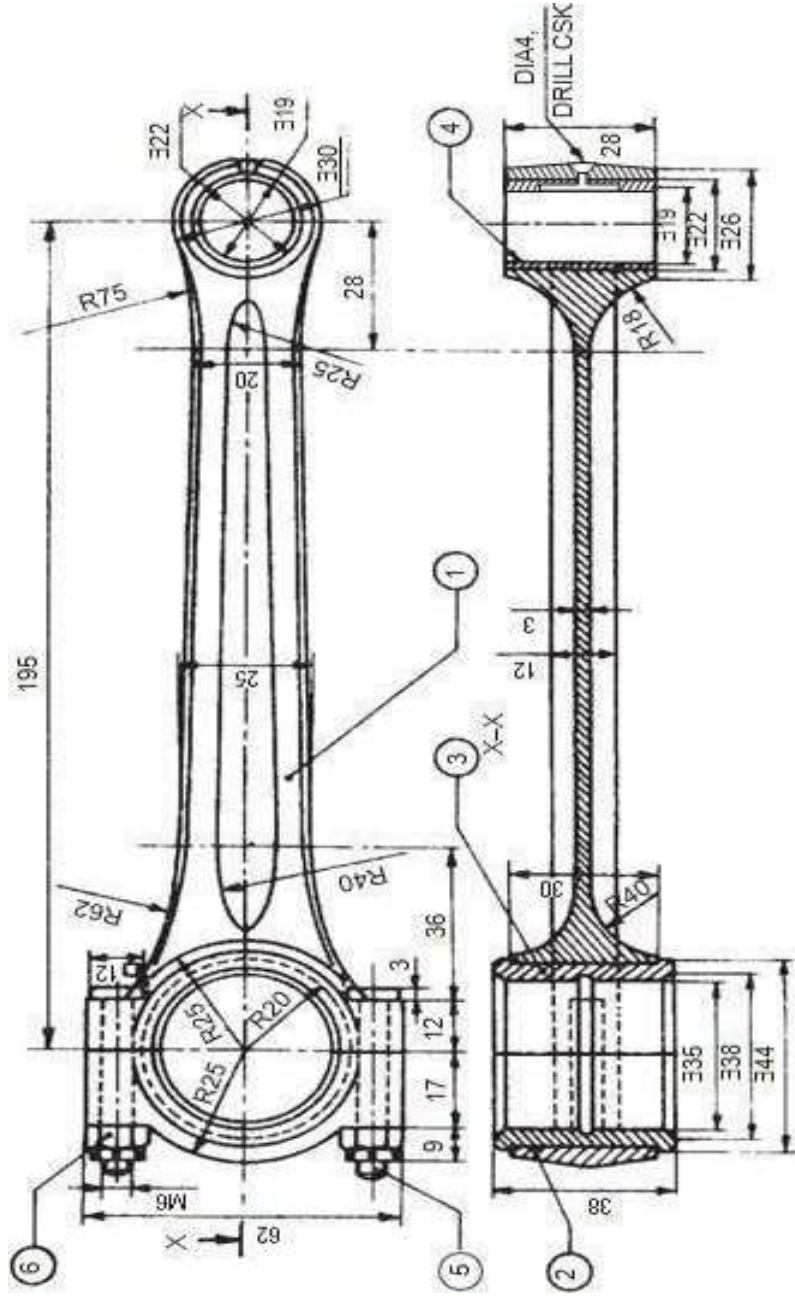

Parts list

Part No.	Name	Matl.	Qty.
1	Rod	FS	1
2	Cap	FS	1
3	Bearing brass	GM	2
4	Bearing bush	P Bronze	1
5	Bolt	MCS	2
6	Nut	MCS	2

# SCREW JACK

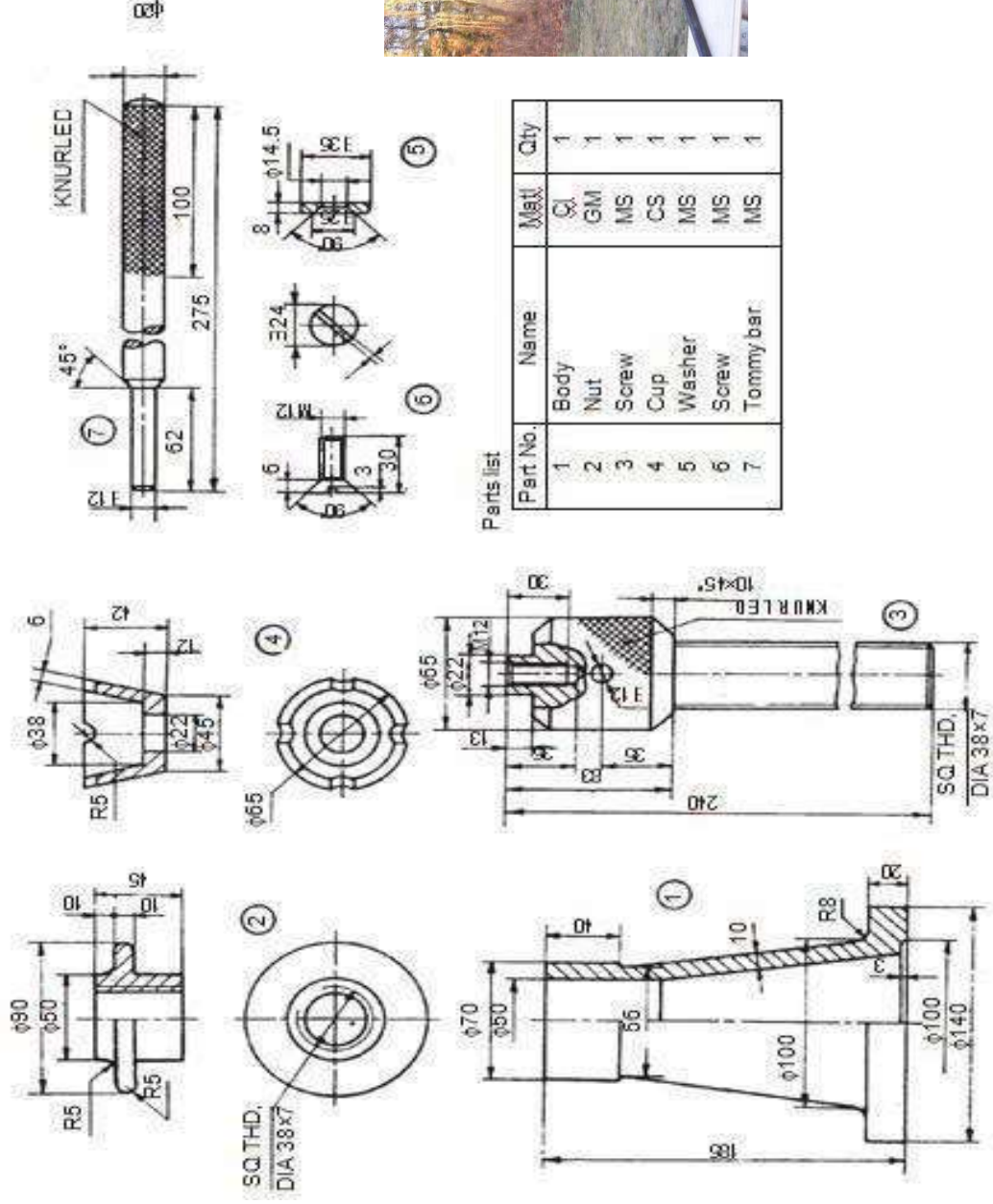

Parts list

Part No.	Name	Matl.	Qty
1	Body	Cl.	1
2	Nut	GM	1
3	Screw	MS	1
4	Cup	CS	1
5	Washer	MS	1
6	Screw	MS	1
7	Tommy bar	MS	1

Screw jack